

SHAC

SHAC



www.shac-usa.com

USA Office:
2501 Chatham Rd Ste R, Springfield,
IL 62704
TEL:+1-424-408-9924
Email: info@shac-usa.com



www.shac-usa.com

Company Profile

SHAC Dinghan – Precision in Motion

The predecessor of SHAC Dinghan, Lishui Yingte, was founded in 2007. Today, SHAC Dinghan is a modern industrial company specializing in research and development, manufacturing, sales, and after-sales service of linear motion components.

Timeline & Milestones

- 2007: Dinghan invested in the first ball screw production line in Lishui, followed by a \$16 million investment in modern production facilities, including rolled and ground ball screws and high-precision ball nuts.
- 2011: Establishment of Taiwan Dinghan Transmission Technology Co., Ltd. in Taiwan as a research and development center.
- 2013: \$21 million invested in Lishui Jiexiang Technology Co., Ltd., the first production base for linear guides and guide carriages on approximately 45,000 m². The current company structure was established:
 - SHAC as the brand
 - Taiwan Dinghan as the R&D center
 - Lishui Jiexiang as the production base
- 2016: SHAC Lishui Jiexiang was recognized as a National High-Tech Enterprise and consistently implemented international management standards such as ISO 9001, ISO 14001, and ISO 45001. The management system continues to evolve to meet growing market demands.
- 2020: Launch of the second production base, Zhejiang Jianzhuang Transmission Technology Co., Ltd. (65,000 m²).
- 2022: SHAC received the award “Specialized, Fine, Unique and Innovative”, reflecting the company’s commitment to delivering high-quality products that meet market and customer requirements and ensure sustainable growth.
- 2025: Opening of the third production base (22,500 m²) and the establishment of SHAC Europe in Switzerland. SHAC Europe serves as a strategic platform for sales, technical consultation, and customer service in Europe, bringing SHAC’s precision philosophy directly to the European market with short decision-making processes, deep market understanding, and a strong focus on quality and service.

Today, SHAC operates three production sites covering a total of approximately 150 acres, ensuring full production capacity for the company.

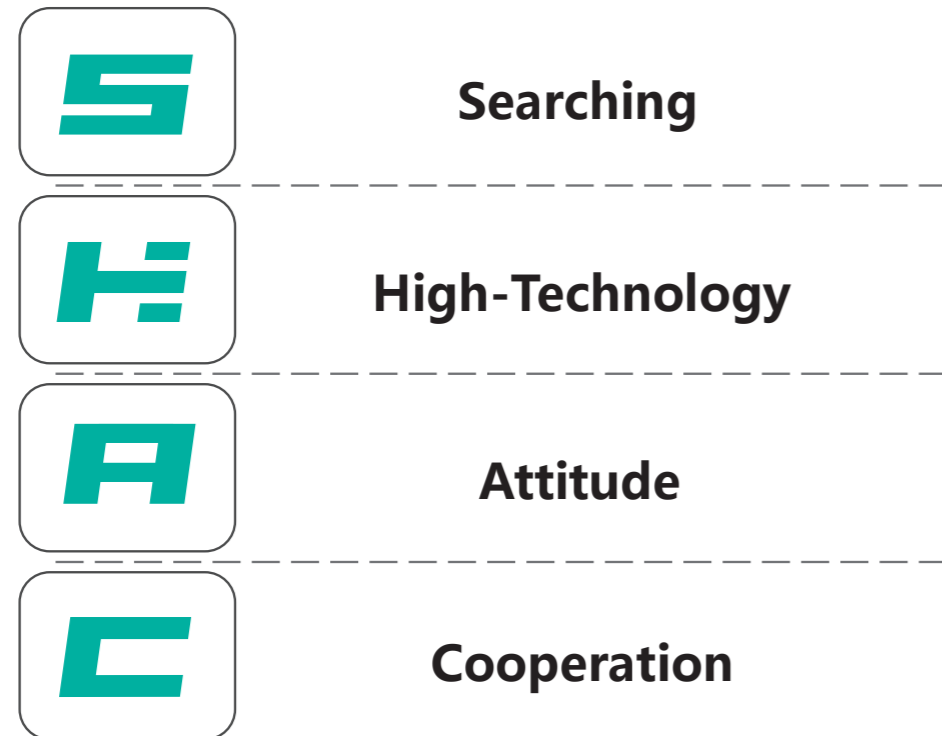

Quality, Network, and Future

SHAC Dinghan consistently follows the corporate strategy:

“Specialized Production, Brand Orientation, and Market Internationalization” Goals:

- Deliver high-quality products that meet market and customer requirements
- Ensure stable and sustainable business development
- Maintain precision, reliability, and robust performance

Global Network:

- Direct sales in more than 30 regions in China
- Partnerships in over 50 countries worldwide

Precision as a Philosophy

All SHAC products are manufactured in China using the latest production technology, guided by a clear principle: Precision as a Benchmark.

- Core Values: uncompromising precision, robust performance, absolute reliability
- Engineering Philosophy: strongly inspired by precision culture and craftsmanship
- Applications: machine tools, automation, robotics, packaging, medical technology, and other high-end industries

Customers value the combination of manufacturing efficiency, technical expertise, and a consistently precision-oriented mindset.

Quality Assurance & Service

- Comprehensive testing and validation systems
- Complete product traceability
- Intelligent inventory management and a global logistics network for short lead times and high supply security

Corporate Motto: “Quality First – Service Credibility First”

Innovation, continuous improvement, and customer satisfaction are SHAC’s primary driving forces. Customers worldwide are warmly welcomed to engage in dialogue and build successful partnerships.



Corporate Chronicle

YEAR	Chronicle
2007	<ul style="list-style-type: none"> ● LISHUI YINGTE bearing co.,ltd ● FIRST PRODUCTION LINE COMMISSIONED: SCREW ROD PROCESSING LINE.
2011	<ul style="list-style-type: none"> ● TAIWAN DINGHAN transmission technology co.,ltd ● DINGHAN WAS ESTABLISHED IN TAIWAN WITH THE COMMENCEMENT OF INDEPENDENT R&D OP- OPERATIONS.
2012	<ul style="list-style-type: none"> ● Ball Nut \ Linear Guideways ● COMMISSIONING OF DEDICATED NUT PRODUCTION LINE AND LAUNCH OF LINEAR GUIDE RAIL MANUFACTURING LINE.
2013	<ul style="list-style-type: none"> ● PRIMARY MANUFACTURING COMPLEX ● EESTABLISHMENT OF JIEXIANG TECHNOLOGY COINCIDED WITH THE COMMISSIONING OF GUIDE RAIL AND SLIDER BLOCK PRODUCTION LINES.
2015	<ul style="list-style-type: none"> ● ROLLED THREAD PROCESS BALL SCREWS VS PRECISION GROUND PROCESS BALL SCREWS ● IIN EARLY 2015, PAIRED PRODUCTION LINES FOR PRECISION GROUND BALL SCREWS AND ROLLED THREAD PROCESS BALL SCREWS WERE COMMISSIONED SIMULTANEOUSLY.
2016	<ul style="list-style-type: none"> ● MANAGEMENT SYSTEM UPGRADE ● THE FIRST-PHASE TRANSFORMATION HAS INSTITUTIONALIZED INNOVATION PRACTICES INTO SYSTEMATIC MANAGEMENT FRAMEWORKS.
2018	<ul style="list-style-type: none"> ● KK-SERIES LINEAR MODULES WITH MINIATURE BALL SCREWS ● PRODUCTION LINES FOR KK-SERIES LINEAR MODULES AND MINIATURE BALL SCREW NUTS UNDERGOING PHASED CAPACITY EXPANSION.
2019	<ul style="list-style-type: none"> ● ENGINEERING DEVELOPMENT OF MISSION-CRITICAL ASSEMBLIES ● TECHNOLOGICAL PROCESS REVOLUTION WITH ENGINEERING DEVELOPMENT OF MISSION-CRITICAL ASSEMBLIES AND PRODUCTION RAMP-UP OF CORE EQUIPMENT.
2020	<ul style="list-style-type: none"> ● SECONDARY MANUFACTURING SITE WITH FULL PROCESS CAPABILITY ● CORPORATE REGISTRATION ESTABLISHED FOR: 1-PRECISION GROUND BALL SCREWS 2- ROLL-FORMED BALL SCREWS 3-BALL NUT 4-ADVANCED ENGINEERING DEVELOPMENT HUB.
2022	<ul style="list-style-type: none"> ● MINIATURE LINEAR GUIDES AND COMPACT CARRIAGES ● R&D AND PRODUCTION OF MINIATURE LINEAR GUIDE UNITS WITH COMMISSIONING OF PEELING BALL SCREWS.
2023	<ul style="list-style-type: none"> ● DIGITAL FACTORY ● PHASE I DIGITAL FACTORY TRANSFORMATION WITH FULL IMPLEMENTATION OF AUTOMATED PRODUCTION & INSPECTION LINES.
2024	<ul style="list-style-type: none"> ● THIRD PRODUCTION BASE ● LARGE-DIAMETER HEAVY-DUTY BALL SCREW

Manufacturing Facility



First Production Base

45000 square meters

Guideway : 500 kilometers per month
Block : One million pieces per month
Pneumatic Clamp : 3 thousand per month
Main production : All Types of Guide Rails/Slider Blocks and New Product Lines

Second Production Base

45000 square meters

Rolled Thread Screw : 100,000 meters per month
Peeling Ball Screw : 5,000 sets per month
Ground Ball Screw : 25,000 sets per month
Ball Nut : 180,000 pieces per month
KK Modules : 15,000 sets per month



Third Production Base

30000 square meters

Heavy-duty Ball Screw : 5,000 sets per month
Key Specifications : Diameter 63, 80, 100, 120 mm, Max length 12 meters

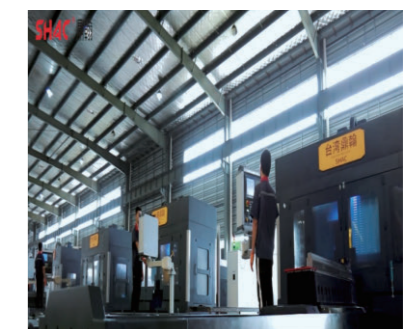
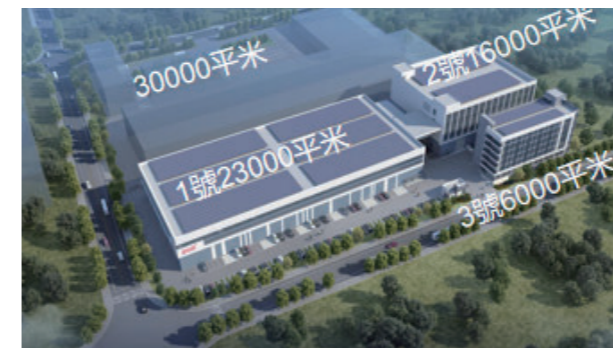

Quality Control

"Precision-Embedded: From Core Integrity to Surface Perfection, Assured."



Corporate Accolades



NATIONAL HIGH-TECH ENTERPRISE CERTIFICATION PLAQUE



ZHEJIANG PROVINCIAL SPECIALIZED & SOPHISTICATED ENTERPRISE PLAQUE

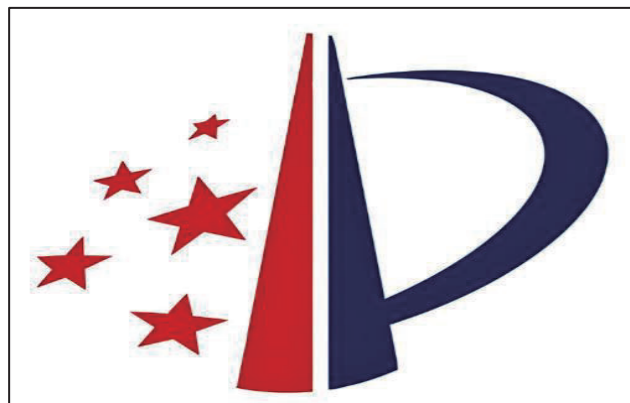

Dinghan products boast nearly 200 patents



CONTENTS

SHAC LINEAR GUIDE

Preface	1
1-1 Features of Linear Guide Rail	2
1-2 Linear Guide Rail Selection Process	3
1-3 A. Application Parameter Setup	3
1-4 B. Corresponding to SHAC products	4
1-5 C. Application of Precision Grades	5
1-5-1 Non-interchangeable Linear Guide Rail Precision	5
1-5-2 Interchangeability of Linear Guide Rail Precision	7
1-6 D. Dimensions Specifications Quantity	9
1-6-3 Static safety factor (fs)	11
1-6-4 Basic Dynamic Load Rating (C)	11
1-6-5 Calculation of service life (L)	12
1-6-6 Hardness coefficient (fH)	12
1-6-7 Temperature coefficient (fT)	13
1-6-8 Load coefficient (fw)	13
1-6-9 Life Calculation (Lh)	14
1-7 E. Slider Load Calculation	14
1-7-1 Single slider bears load	14
1-7-2 Inertia load	20
1-7-3 Equivalent load in two directions	20
1-7-4 Selection of the static safety factor	22
1-8 F. Pre-compression Installation Accuracy	23
1-9 G. Rigid Deformation Confirmation	24
1-9-1 Rigidity Calculation Formula in Mechanics of Materials	25
1-9-2 Linear Guide Rail Rigidity Calculation	25
1-10 H. Service Life Calculation	27
1-10-1 Calculation of service life	28
1-10-2 Friction	29
1-11 I Selection of Lubrication Positions	29
1-11-1 Lubricating Grease	30
1-11-2 Grease Frequency	30
1-11-3 Lubrication Methods	30
1-11-4 Lubrication nozzle style (a)	31
1-11-5 Oil Nozzle Specifications	33
1-11-6 Oil Nozzle Position	33
1-11-7 Lubricating oil capacity for single slider	34

1-11-8 Sliding Method and Frequency	34	2-2-11 Lubrication mode and frequency	65
1-12J Noise Reduction Requirements	34	2-2-12 Dust-proof fitting and code	66
1-12-1 QH Series - Silent Heavy-Duty Ball Linear Guide Rail	35	2-2-13 Allowable error of mounting surface	68
1-12-2 Low noise design	36	2-2-14 Precautions for installation	68
1-12-3 Self-lubricating design, no need to add oil	37	2-2-14 Specification and torsion of guide rail mounting screw	69
1-12-4 Improve the smoothness of movement	37	(1) GHH-CA / GHH-HA	70
1-12-5 High-speed Design	38	(2) GHL-CA / GHL-HA	72
1-13 K. Surface treatment	38	(3) GHW-CA / GHW-HA	74
1-13-1 Improve wear resistance	39	(4) GHW-CB / GHW-HB	76
1-13-2 Enhance corrosion resistance	39	(5) GHW-CC / GHW-HC	78
1-14 L. Dustproof design	39	(6) LHH-CA / LHH-HA	80
1-14-1 External protective devices	39	(7) LHW-CC / LHW-HC	82
1-14-2 Sliding block dustproof accessories	40	(8) GHH-CA-S / GHH-HA-S	84
1-14-3 High dustproof accessory code	41	(9) GHW-CC-S / GHW-HC-S	86
1-14-4 Friction Force	42	(10) GHRT	88
1-15 M. Rail butt-joint	42	2-3 GE Series - Low Assembly Ball Linear Guide	89
1-16 N. Guide rail configuration	43	2-3-1 Product model of non-interchangeable linear guide rail	91
1-16-1 Configuration of single guide rail bearing surface	43	2-3-2 Product model of interchangeable linear guide rail	92
1-16-2 Two rail sliders movement configuration	43	2-3-3 GE Series - Low Assembly Ball Linear Guide	93
1-16-3 configuration of two opposite/back facing guide rails	44	2-3-4 Precision of non-interchangeable linear guide rail	94
1-16-4 Comprehensive fixed configuration	45	2-3-5 Precision of interchangeable linear guide rail	95
1-17 O. Installation of guide rails	45	2-3-6 Traveling parallel precision	96
1-17-1 Representation of straight-line guide benchmark measurement	45	2-3-7 Grade of Preload	97
1-17-2 Installation when there is vibration and impact during machine operation and high rigidity and precision are required	46	2-3-8 Lubricating oil capacity of single sliding block	98
1-17-3 Rail fixing method	46	2-3-9 Lubrication frequency	98
1-17-4 Guide rail installation	47	2-3-11 Allowable error of mounting surface	101
1-17-5 slider installation	47	2-3-12 Precautions for installation	102
1-17-6 Installation of guide rails without side positioning screws	48	(1) GEH-SA / GEH-CA	104
1-17-7 The machine does not have a supporting surface for installation	49	(2) GEW-SA / GEW-CA	106
2. Product Series	50	(3) GEW-SB / GEW-CB	108
2-1 Product Structure and Advantages	52	(4) GEW-SC / GEW-CC	110
2-1-1 Names of each part of the linear slide rail	53	2-4 QH Series - Silent Heavy Duty Ball Linear Guide	117
2-2 GH Series - Heavy Duty Ball Linear Guide	53	Products Characteristic	117
2-2-1 GH Series - Heavy Duty Ball Linear Guide	55	Self-lubricating	117
2-2-2 Product model of interchangeable linear guide rail (sliding block)	56	Good smoothness	118
2-2-3 Recommended Applicable Equipment	57	High-speed Design	119
2-2-4 GH series slide block type	58	Products structure	119
2-2-5 Precision of non-interchangeable guide rail	59	2-4-1 Product model of non-interchangeable linear guide rail	120
2-2-6 Interchangeability guide rail accuracy	61	2-4-2 Product model of interchangeable linear guide rail	121
2-2-7 Traveling parallel precision	62	2-4-3 QH Series - Silent Heavy Duty Ball Linear Guide	122
2-2-8 Grade of Preload	63	2-4-4 Precision of non-interchangeable guide rail	123
2-2-9 Way of lubrication	64	2-4-5 Interchangeability guide rail accuracy	124
2-2-10 Lubricating oil capacity of single sliding block	65	2-4-6 QH Series	125
		2-4-7 Traveling parallel precision	125

2-4-8	Grade of Preload	126	2-7-1	GMN Series - Miniature Ball Linear Guide	189
2-4-9	Lubrication frequency	127	2-7-2	GM series product types	189
2-4-10	Allowable error of mounting surface	129	2-7-3	Product model of non-interchangeable linear guide rail	190
2-4-11	Precautions for installation	130	2-7-4	Product model of interchangeable linear guide rail (sliding block)	190
	(1) QHH-CA / QHH-HA	132	2-7-5	Accuracy of non interchangeable linear guides	191
	(2) QHW-CA / QHW-HA	134	2-7-6	Accuracy of interchangeable linear guide rail	192
	(3) QHW-CB / QHW-HB	136	2-7-7	Traveling parallel precision	192
	(4) QHW-CC / QHW-HC	138	2-7-8	Preload	193
2-5	QE Series - Silent Low Assembly Ball Linear Guide	140	2-7-9	Installation precautions	195
2-5-1	Product model of non-interchangeable linear guide rail	141	2-7-10	Standard length and maximum length of a single guide rail	196
2-5-2	Product model of interchangeable linear guide rail	142		(1) GMN-C / GMN-H	198
2-5-3	QE Series - Silent Low Assembly Ball Linear Guide	143		(2) GMW-C / GMW-H	200
2-5-4	Precision of non-interchangeable linear guide rail	144	2-8	WE Series Wide-Format Ball Linear Guide	202
2-5-5	Precision of interchangeable linear guide rail	145	2-8-1	Product model of non-interchangeable linear guide	203
2-5-6	Traveling parallel precision	146	2-8-2	Interchangeable Linear Guide Product Models	204
2-5-7	Grade of Preload	147	2-8-3	WE series slide block type	205
2-5-8	Lubrication frequency	148		(1) WEH-CA	206
2-5-9	Allowable error of mounting surface	150		(2) WEW-CC	208
2-5-10	Precautions for installation	151	3	Clamp	210
	(1) QEH-CA / QEH-SA	152	3-1	Structure and Function	210
	(2) QEW-SA / QEW-CA	154	3-2	Purpose	210
	(3) QEW-CB / QEW-SB	156	3-3	Advantage	210
	(4) QEW-CC / QEW-SC	158	3-4	Principle	211
2-6	GR Series - Roller Linear Guide	160		QK Series - Pneumatic Normally Open Clamp	212
2-6-1	Product model of non-interchangeable linear guide rail	164		QB Series - Pneumatic Normally Open Clamp	213
2-6-2	Product model of interchangeable linear guide rail	165	Preface		214
2-6-3	GR Series - Roller Linear Guide	166	1.	Fundamental Data	215
2-6-4	Precision of non-interchangeable linear guide rail	167	1-1.	Ball screw Characteristics	215
2-6-5	Precision of interchangeable linear guide rail	168	1-2	Step-by-Step Selection Guide	217
2-6-6	Travel parallelism accuracy	169		1-2-1 Requirements:	217
2-6-7	Grade of Preload	170		1-2-2 8-Step Selection Procedure	218
2-6-8	Way of lubrication	170	1-3	Accuracy Grade Selection ①	218
2-6-9	Lubricating oil capacity of single sliding block	171		1-3-1 Definition of Positioning Accuracy	218
2-6-10		172		1-3-2 Cumulative Lead Error Comparison Table	219
2-6-11	Allowable error of installation surface	175		1-3-3 Accuracy Grade Comparison Table	220
2-6-12	Plane precision of slide block installation	175		1-3-4 Ball Screw Mounting Interface Precision	221
2-6-13	Precautions for installation	176	1-4	Ball Screw Journal/Shaft End Configuration Selection ②	225
2-6-14	Standard length and maximum length of a single guide rail	177		1-4-1 Mounting Configuration	225
	(1) GRH-SA / GRH-CA / GRH-HA	178		1-4-2 Screw Shaft End Dimensions	227
	(2) GRL-SA / GRL-CA / GRL-HA	180	1-5	Ball Screw Drive Torque ③	229
	(3) GRW-SC / GRW-CC / GRW-HC	182		1-5-1 Preload Torque	229
	(4) GRH-SA-S / GRH-CA-S / GRH-HA-S	184		1-5-2 Driving Torque	231
	(5) GRW-SC-S / GRW-CC-S / GRW-HC-S	186			
2-7	GMN Series - Miniature Ball Linear Guide	188			

1-6 Ball Screw Nut Selection ④	232	4-A-1 Allowable speed	267
1-6-1 Nut Selection	232	4-A-2 Load factor (same on page 24)	268
1-6-2 Nut Configuration	233	4-A-3 Safety factor	268
1-7 Ball Screw Rigidity Design ⑤	235	4-B DN Value	268
1-7-1 Rigidity (K)	235	4-B-1 DN Value of Shaft	269
1-7-2 Nut Axial Stiffness KN and Nut Deformation δN	236	4-B-2 DN Value of Nut	269
1-8 Positioning Accuracy of Ball Screw ⑥	238	4-B-3 Effective stroke	269
1-8-1 Selection of Lead Accuracy for Ball Screw	238	4-B-4 Slenderness ratio	269
1-8-2 Temperature Control for Lead Accuracy	239	4-B-5 Pre-load range	270
1-9 Ball Screw Life Calculation ⑦	241	4-C Critical speed	271
1-9-1 Ball Screw Service Life	241	4-D Buckling load	272
1-9-2 Ball Screw Life Calculation Example	243	4-E Lead Accuracy	273
1-10 Precautions for using ball screw ⑧	257	4-F Nut cycle mode	274
1-10-1 Nut disassembly and assembly	257	4-F-1 Internal circulation nut	274
1-10-2 Lubrication	257	4-F-2 End-plug nut	274
1-10-3 Protective measures	258	4-F-3 External plugging circulating nut (new)	274
1-10-4 Partial load (Radial force)	258	Hollow Cooling Ball Screw	275
1-10-5 Shaft end machining	259	H.1 Design Principles:	275
2 Comprehensive accuracy after installation of ball screw	260	H.2 Cooling System Function	275
2-1 Axial clearance (Install)	260	H.3 Summary	276
2-2 Reverse gap (laser detection)	260	H.4 Performance:	276
2-3 Reproducibility of lead accuracy (laser detection)	261	H.5 Test and Inspection Report	278
2-4 Circular accuracy detection (laser detection)	261	H.6 Application	279
2-5 The key to prestretching (Figure 2.5.1)	262	H.7 Features:	279
3 Abnormal operating factors and elimination	263	H.8 Technical Specifications: Three Advantages of Hollow Ball Screw:	280
3-1 Poor accuracy	263	H.9 Specifications and Model:	280
3-1-1 Positioning accuracy	263	5 SHAC Ball Screw Product Series	281
3-1-2 Backlash	263	5-1 Nominal Model Code of SHAC Ball Screw	281
3-1-3 Circular exceeding tolerance	263	5-1-2 Shaft Specification:	282
3-1-4 Insufficient rigidity	263	5-1-3 Nut Specifications:	282
3-1-5 Thermal displacement	264	5-2 Rolled Ball Screw	282
3-2 Poor operation	264	5-2-1 Rolled Screw Shaft Standard Specifications	285
3-2-1 Processing problem	264	5-3 Ground Ball Screw Standard Specifications	288
3-2-2 Foreign Object	264	5-3-1 Nut Code	289
3-2-3 Adjustment Issues	264	5-4 Grinding Ball Screw Standard Model No. Series	290
3-2-4 Component Failure	264	Size Table of SFBH Ball Screw (Heavy-duty Tubular Type)	290
3-2-5 Lubrication Issues	264	Size Table of SFB/DFB Ball Screw	291
3-3 Breakage and damage	265	Size Table of DFDC Ball Screw	292
3-3-1 Screw fracture	265	Size Table of SFDC Ball Screw	296
3-3-2 Steel Ball Damage	265	Size Table of DFNU Ball Screw	300
3-3-3	265	Size Table of SFNU Ball Screw	301
3-4 Areas prone to abnormalities	265	SFUH Special for Electric Cylinders	302
4. Selection verification of ball screw	266	Size Table of SFKH Ball Screws (Heavy)	303
4-A. Velocity	267	Size Table of SFY Ball Screw	304

Size Table of OFNU Ball Screw	305
Size Table of OFNI Ball Screw	306
Size Table of DFS Ball Screw	307
Size Table of SFS Ball Screw	308
Size Table of DFNI Ball Screw	310
Size Table of SFNI Ball Screw	311
Size Table of SFA Ball Screw	312
Size Table of SFK Ball Screw	314
Size Table of SMA Ball Screw	315
6 Appendix	316

SHAC KK module

Preface	318
(A) Product Structure	319
(B) Product Features	320
(C) Comprehensive comparison	322
(D) Product Application	323
(E) Selection steps	324
(F) key technology	325
(G) Instructions for Use	327
(H) Related matters	329
(I) KK Compact Module Product Model	331
(J) Maximum speed	332
(K) Load specifications	334
(L) Accuracy grade	336
Motor and connection flange	337
(M) Motor connection flange	338
KK40 Motor Adaptor Flange	338
KK40D Motor Adaptor Flange	339
KK50 Motor Adaptor Flange	340
KK60 Motor Adaptor Flange	341
KK60D Motor Adaptor Flange	342
KK86 Motor Adaptor Flange	343
KK86D Motor Adaptor Flange	344
KK100 Motor Adaptor Flange	345
KK130 Motor Adaptor Flange	346
(N) Dinghan KK series	347
KK40 (Excluding protective cover)	347
KK40D (Excluding protective cover)	348
KK50 (Excluding protective cover)	349
KK60 (Excluding protective cover)	350
KK60 (Excluding protective cover \ Light load type)	351
KK60D (Excluding protective cover)	352

KK60D (Excluding protective cover \ Light load type)	353
KK86 (Excluding protective cover)	354
KK86 (Excluding protective cover \ Light load type)	355
KK86D (Excluding protective cover)	356
KK86D (Excluding protective cover \ Light load type)	357
KK100 (Excluding protective cover)	358
KK130 (Excluding protective cover)	359
16 Dinghan KK series	360
KK40 (Including protective cover)	360
KK40D (Including protective cover)	361
KK50 (Including protective cover)	362
KK60 (Including protective cover)	363
KK60 (Including protective cover \ Light load type)	364
KK60D (Including protective cover)	365
KK60D (Including protective cover \ Light load type)	366
KK86 (Including protective cover)	367
KK86 (Including protective cover \ Light load type)	368
KK86D (Including protective cover)	369
KK86D (Including protective cover \ Light load type)	370
KK100 (Including protective cover)	371
KK130 (Including protective cover)	372

SHAC

>>>

SHAC LINEAR GUIDE

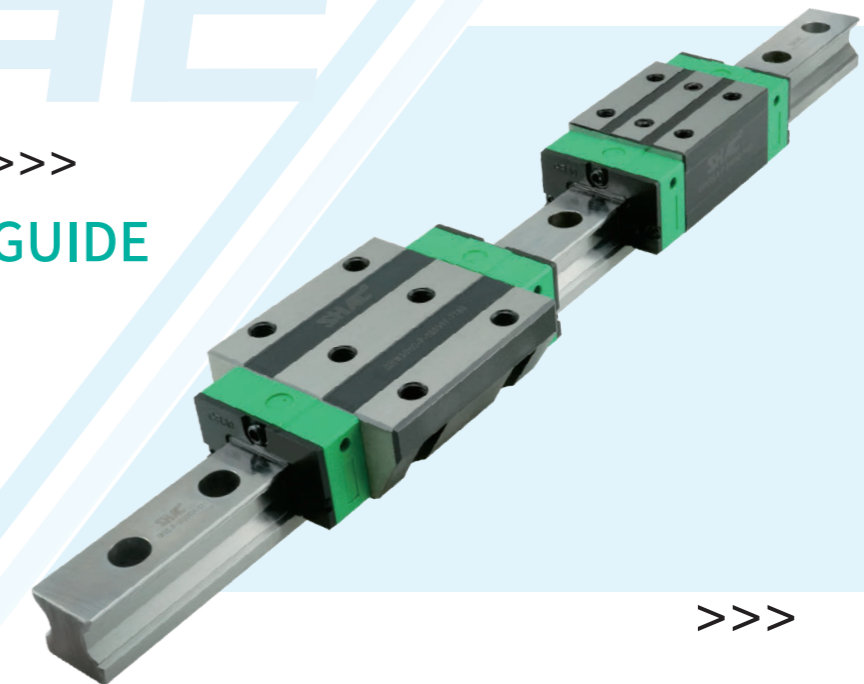

>>>

Preface

Rolling linear guides achieve high-precision linear motion by allowing rolling elements to perform infinite rolling cycles between the slider and guide rail, requiring only minimal frictional resistance.

As an efficient and high-precision rolling guide component, they significantly enhance precision, speed, and reliability compared to traditional sliding guides while substantially reducing contact surface wear and operational noise.

These components play an indispensable role as functional components in numerical control (CNC) machines, optical machinery, precision instruments, and various automated equipment.



Overhead view the ball way is visible

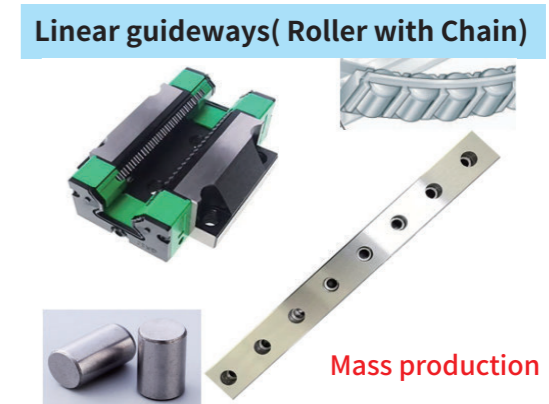

Mass production

From above, the rolling element raceway is not visible

1-1 Features of Linear Guide Rail

1. Low Frictional Resistance: Due to the use of balls or rollers as transmission media, rolling frictional resistance is significantly less than sliding frictional resistance.

The lower operational resistance results in reduced wear on contact surfaces, allowing for prolonged maintenance of walking precision.

Walking precision is one of the key performance indicators of linear guides, and the walking precision of linear guides directly affects the walking precision of the entire drive system.

2. High positioning accuracy The friction force of linear guideways during operation is rolling friction, with a rolling friction coefficient only about 1/20 to 1/40 of the sliding friction coefficient.

Due to the minimal difference between kinetic and static friction coefficients, crawling phenomenon is unlikely to occur even at low-speed feed, resulting in extremely high positioning accuracy.

3. The mechanical structure is rational.

The friction force of linear guideways during operation is rolling friction, with a rolling friction coefficient only 1/20-1/40 of the sliding friction coefficient.

Due to the minimal difference between dynamic and static friction coefficients, crawling phenomenon is unlikely even at low feed rates, resulting in extremely high positioning accuracy.

4. Superior high-speed performance Thanks to the low frictional resistance of the system, the requirement for driving force is reduced accordingly, allowing smaller power motors to drive the machine normally.

The lower operational resistance also effectively controls system temperature rise, minimizes thermal deformation, and enables prolonged high-speed operation without compromising precision.

5. Simple Installation and Maintenance: Achieve the precision achieved during processing by following a specific installation sequence and requirements.

The simple and user-friendly lubrication structure effectively maintains lubrication performance over the long term.

The interchangeable design allows damaged components to be replaced or repaired simply to restore the machine to normal operation.



1-2 Linear Guide Rail Selection Process

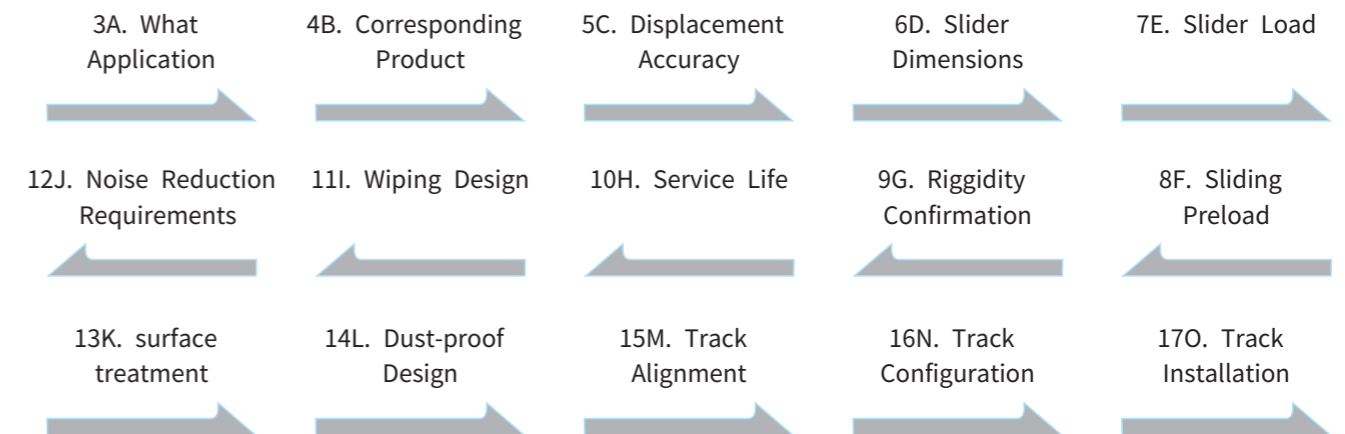

1-3 A. Application Parameter Setup

Table 1-3-1

1	pre-established structural equipment	6	factors influencing movements	Note
2	Spatial Interference Dimension Usage	7	Displacement velocity and acceleration	A. Consider the order of steps based on the key aspects of the requirements
3	Loading methods for the track	8	Device Application Frequency Impact	B. Guide rail dimensions must be matched with equipment dimensions
4	assessment of the structural rigidity of the guide rail	9	Operating Environmental Conditions	C. When using for high-precision applications, consider paired use
5	Equipment Pairing Guide Rail Accuracy	10	Linear guide rail life limit	

Table 1-3-2

Item	Use conditional settings	Corresponding explanation	Suggested Solution
1	Application	CNC equipment, non-CNC equipment;	GH, GE, GM, GR, QR Series
2	Equipment Internal Space Limit	height, width, center of gravity;	Flange, Square, High resistance, Low resistance, Medium load
3	Precision Requirements	walking parallelism;	Page 5, Table 2-1-11
4	Rig Requirements	pre-compression level;	Page 16, Table 1-8-2
5	Load Method	horizontal or vertical, crossbeam;	Dynamic and static loads, permissible stress distance, lower locking type fixation
6	Operation Conditions	effective stroke;	Rail specifications, Fixed hole spacing
7	Speed and Acceler	speed (m/min), area (m ²);	Page 93, 120m/min
8	Usage	operating time, number of cycles;	Page 58, dust-proof accessories DD, KK, ZZ
9	Usage Environment	dust, high temperature, special;	Page 92, Service Life Calculation
10	Service Life Requirements	theoretical lifespan, actual lifespan	

1-4 B. Corresponding to SHAC products

Table 1-4-1

SHAC Products: High precision grade, high-speed matching, high load capacity, high versatility design, noise-free					
Use Conditions	related equipment				Recommended Plan
CNC Machining Equipment	CNC Machine Cente	Electrical Discharge Machine	Lathe	Woodworking Machine	GH series
Precision Space Constraints	Automation Industry	Electronic Semiconductors	laser machining equipment	3D Printing Equipment	GE series
Precision High-Speed Quiet	High-speed Spray Printer	Chip-Related Equipment	quiet-related equipment	Laser Engraving Machine	QE/QH series
Precision Torque Load High	Torque Offset Application	Special Automation	single-axis robot arm	Precision Measuring Instruments	WE/QW series
Precision Light Load	Miniature Medical Structures	Small Electronic Instruments	chip equipment	Pneumatic Component Applications	GM series
CNC Heavy-Duty Equipment	CNC Tool Machine	CNC Grinding Machine	heavy-duty machining equipment	Injection Molding Machine	GR series

1-5 C. Application of Precision Grades

Linear guide rails have five precision levels: Ultra-Precision Level (UP), Super-Precision Level (SP), Precision Level (P), High Level (H), and Ordinary Level (C). Refer to the precision comparison table for matching purposes.

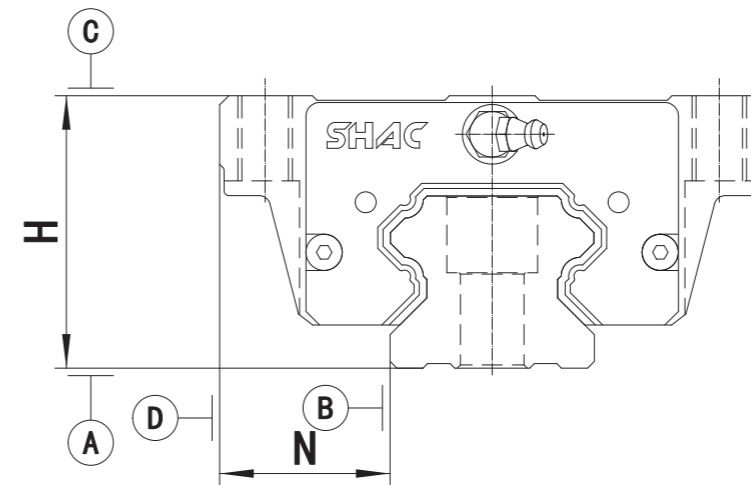

Figure 1-5-1

Linear Rail Precision Selection: In addition to general reference for existing equipment, assessments can be conducted on:

- 1- Rail running parallelism (C to A, D to B);
- 2- Slider interchangeability (rail slider sets vs. individual sliders);
- 3- Individual slider dimensional accuracy (permissible values for H height and W width);
- 4- Dimensional accuracy between sliders (height difference in pairs)

1-5-1 Non-interchangeable Linear Guide Rail Precision

The precision of linear guide rails is divided into five grades: ultra-high precision, super precision, precision, standard, and general. Customers can select the appropriate precision grade based on equipment requirements.

Table 1-5-2 Assembly accuracy Table

Unit : mm

Model No.	GH-15, 20				
Grade of accuracy	Ultra-Precision Level (UP)	Super-Precision Level (SP)	Precision Level (P)	High Level (H)	Ordinary Level (C)
Allowable size tolerance for height H	0 -0.008	0 -0.015	0 -0.03	±0.03	±0.1
permissible dimensional tolerance of width N	0 -0.008	0 -0.015	0 -0.03	±0.03	±0.1
Mutual error of paired heights H	0.003	0.004	0.006	0.01	0.02
Mutual error of paired width N	0.003	0.004	0.006	0.01	0.02
Parallelism of Slider C facing the A face of Guide Rail	Travel Parallelism (see Table 1-5-11)				
Parallelism of Slider D facing the B face of Guide Rail					

Table 1-5-3 Assembly accuracy Table

Unit : mm

Model No.	GH—25, 30, 35				
Grade of accuracy	Ultra-Precision Level (UP)	Super-Precision Level (SP)	Precision Level (P)	High Level (H)	Ordinary Level (C)
Allowable size tolerance for height H	0 -0.01	0 -0.02	0 -0.04	±0.04	±0.1
permissible dimensional tolerance of width N	0 -0.01	0 -0.02	0 -0.04	±0.04	±0.1
Mutual error of paired heights H	0.003	0.005	0.007	0.015	0.02
Mutual error of paired width N	0.003	0.005	0.007	0.015	0.03
Parallelism of Slider C facing the A face of Guide Rail	Travel Parallelism (see Table 1-5-11)				
Parallelism of Slider D facing the B face of Guide Rail					

Table 1-5-4 Assembly accuracy Table

Unit : mm

Model No.	GH—45, 55				
Grade of accuracy	Ultra-Precision Level (UP)	Super-Precision Level (SP)	Precision Level (P)	High Level (H)	Ordinary Level (C)
Allowable size tolerance for height H	0 -0.02	0 -0.03	0 -0.05	±0.05	±0.1
permissible dimensional tolerance of width N	0 -0.02	0 -0.03	0 -0.05	±0.05	±0.1
Mutual error of paired heights H	0.003	0.005	0.007	0.015	0.03
Mutual error of paired width N	0.005	0.007	0.01	0.02	0.03
Parallelism of Slider C facing the A face of Guide Rail	Travel Parallelism (see Table 1-5-11)				
Parallelism of Slider D facing the B face of Guide Rail					

Table 1-5-5 Assembly accuracy Table

Unit : mm

Model No.	GH—65				
Grade of accuracy	Ultra-Precision Level (UP)	Super-Precision Level (SP)	Precision Level (P)	High Level (H)	Ordinary Level (C)
Allowable size tolerance for height H	0 -0.03	0 -0.05	0 -0.07	±0.07	±0.1
permissible dimensional tolerance of width N	0 -0.03	0 -0.05	0 -0.07	±0.07	±0.1
Mutual error of paired heights H	0.005	0.007	0.01	0.02	0.03
Mutual error of paired width N	0.007	0.01	0.015	0.025	0.03
Parallelism of Slider C facing the A face of Guide Rail	Travel Parallelism (see Table 1-5-11)				
Parallelism of Slider D facing the B face of Guide Rail					

Table 1-5-6

Item	Use conditional settings	Corresponding explanation	Suggested Solution
1	Industrial Equipment, Automation	Packaging Machinery, Papermaking Machinery, Sheet Metal Shearing Machine	C
2	Precision Machinery Worker, Automation	Vertical Machining Center, CNC Lathe, Laser Cutting Machine, Woodworking Machinery	H
3	High Precision Machinery	Horizontal Machining Center, Semiconductor Equipment, Multi-axis Machining Equipment	P
4	High Precision Machinery, Instrumentation	CNC Grinding Machine, CNC Machining Machine, Industrial Robots	SP
5	Instrumentation, Experimental Equipment	Precision Measuring Instruments	UP

1-5-2 Interchangeability of Linear Guide Rail Precision

The precision of linear guide rails is divided into three levels: precision-grade, high-grade, and standard-grade. Customers can select the appropriate precision level based on their equipment's requirements.

Table 1-5-7 Single output accuracy table

Unit : mm

Model No.	GH—15, 20		
Grade of accuracy	Precision Level (P)	High Level (H)	Ordinary Level (C)
Allowable size tolerance for height H	±0.015	±0.03	±0.1
permissible dimensional tolerance of width N	±0.015	±0.03	±0.1
Mutual error of paired heights H	0.006	0.01	0.02
Mutual error of paired width N	0.006	0.01	0.02
Parallelism of Slider C facing the A face of Guide Rail	Travel Parallelism (see Table 1-5-11)		
Parallelism of Slider D facing the B face of Guide Rail			

Table 1-5-8 Single output accuracy table

Unit : mm

Model No.	GH—25, 30, 35		
Grade of accuracy	Precision Level (P)	High Level (H)	Ordinary Level (C)
Allowable size tolerance for height H	±0.02	±0.04	±0.1
permissible dimensional tolerance of width N	±0.02	±0.04	±0.1
Mutual error of paired heights H	0.007	0.015	0.02
Mutual error of paired width N	0.007	0.015	0.03
Parallelism of Slider C facing the A face of Guide Rail	Travel Parallelism (see Table 1-5-11)		
Parallelism of Slider D facing the B face of Guide Rail			

Table 1-5-9 Single output accuracy table

Unit : mm

Model No.	GH—45, 55		
Grade of accuracy	Precision Level (P)	High Level (H)	Ordinary Level (C)
Allowable size tolerance for height H	±0.025	±0.05	±0.1
permissible dimensional tolerance of width N	±0.025	±0.05	±0.1
Mutual error of paired heights H	0.007	0.015	0.03
Mutual error of paired width N	0.01	0.02	0.03
Parallelism of Slider C facing the A face of Guide Rail	Travel Parallelism (see Table 1-5-11)		
Parallelism of Slider D facing the B face of Guide Rail			

Table 1-5-10 Single output accuracy table

Unit : mm

Model No.	GH—65		
Grade of accuracy	Precision Level (P)	High Level (H)	Ordinary Level (C)
Allowable size tolerance for height H	±0.035	±0.07	±0.1
permissible dimensional tolerance of width N	±0.035	±0.07	±0.1
Mutual error of paired heights H	0.01	0.02	0.03
Mutual error of paired width N	0.015	0.025	0.03
Parallelism of Slider C facing the A face of Guide Rail	Travel Parallelism (see Table 1-5-11)		
Parallelism of Slider D facing the B face of Guide Rail			

Table 1-5-11 Traveling Parallel Accuracy

Rail Length (mm)	Grade of Accuracy (μm)				
	UP	SP	P	H	C
~	2	2	3	7	12
100~200	2	2	4	9	14
200~300	2	3	5	10	15
300~500	2	3	6	12	17
500~700	2	4	7	13	20
700~900	3	5	8	15	22
900~1100	3	6	9	16	24
1100~1500	4	7	11	18	26
1500~1900	4	8	13	20	28
1900~2500	5	10	15	22	31
2500~3100	6	11	18	25	33
3100~3600	7	14	20	27	36
3600~4000	7	15	21	28	37

1-6 D. Dimensions Specifications Quantity

◎Based on experience ◎Load condition ◎Similar specifications

1-6-1 The basic application of a slider involves either one slider and one guide rail, or two sliders on a single guide rail. For structural stability, a dual-slider single-axis configuration or even a multi-slider single-axis setup may be adopted.

1-6-2 Gradually increase the slider size and quantity as the load increases.

1-6-3 When used with a ball screw, select linear guide rail specifications matching the ball screw outer diameter. For example, if the ball screw has a 32mm diameter, choose similar GH35 specifications

When selecting a ball screw, if the linear guide GH35 is known, then select a screw with an outer diameter of 32mm; you can also refer to the manual SHAC Page

Item	Use conditional settings	Corresponding explanation	Suggested Solution
1	Selected based on experience	If no special design is required, the same equipment can generally use the same specifications	Copy and use
2	Based on load conditions	Horizontal axes (X, Y) vertical (Z)	there is an additional torque in the vertical direction
3	Based on analogous dimensions	For reference, when selecting similar specifications for ball screws, for example, a ball screw with an outer diameter of 20mm can be selected as a 20 guide rail	In general applications, both can refer to each other and adopt the same dimensions

The application of linear guides must involve calculating their load capacity and service life based on the selected model and operating conditions. Based on these results, the suitability of the selected linear guide model can be determined. The verification of load capacity involves using the basic rated static load (C_0) to determine the static safety factor and establish the static load limit. The verification of service life, on the other hand, employs the basic rated dynamic load (C) to calculate the rated life. The lifespan of linear guides refers to the total distance traveled by rolling elements or rolling surfaces under cyclic stress until metal surface spalling occurs due to rolling fatigue in the material.

Basic rated static load (C_0) When linear guides are subjected to excessive or impact loads during stationary or low-speed operation, permanent deformation will occur between the rolling elements and the raceway surfaces. If the permanent deformation exceeds a certain limit, it will affect the smoothness of the linear guide's motion.

The basic rated static load (C_0) refers to a static load with a specified direction and magnitude applied to the contact surface where maximum stress occurs, such that the total permanent deformation between the rolling element and the raceway reaches 0.0001 times the diameter of the rolling element. Therefore, the basic rated static load represents the limit of permissible static load.

Allowable static torque (M_0) When a static torque is applied to a linear guide, from the stress distribution of the rolling elements within the linear guide, the rolling elements at both ends experience the highest stress. The allowable static torque (M) refers to a static torque with a specific direction and magnitude applied at the contact surface where maximum stress occurs, such that the total permanent deformation between the rolling elements and the rolling surfaces reaches 0.0001 times the diameter of the steel balls. Therefore, the allowable static torque represents the maximum limit of static torque that can be applied. In linear guides, this torque is defined in three directions: M_r , M_p , and M_y .

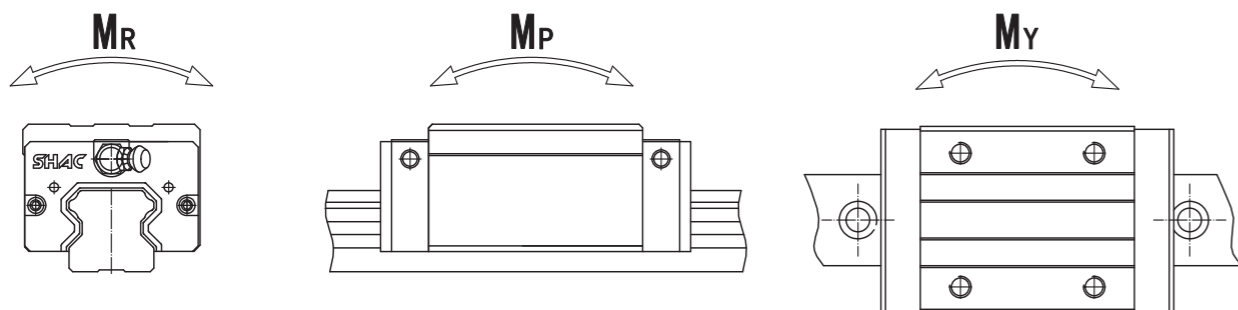

Figure 1-6-1

Note: During the selection of linear guide rails, in addition to evaluating static and dynamic loads, installation and usage characteristics may generate additional static torques in the three directions shown as M_r , M_p , and M_y in the diagram. SHAC provides corresponding data for each series of dimensions and specifications in the table for your reference.

1-6-3 Static safety factor (f_s)

When linear guide rails are used in situations involving vibration, impact, or sudden start-stop operations, due to external forces such as inertial forces or torque, significant loads will be generated. For such loading conditions, it is necessary to consider a safety factor.

The static safety factor (f) is expressed as the multiple of the basic static load rating (C_0) relative to the load applied to the linear guide, as shown in the formula below. The reference values of static safety factors for various application conditions are as shown in the following table.

$$f_s = \frac{C_0}{P} \text{ Or } f_s = \frac{M_0}{M}$$

f_s Static Safety Factor
 C_0 Basic Rated Static Load (N)
 M_0 Allowable Static Torque (N·m)
 P Calculated Load (N)
 M Calculated Torque (N·m)

Formula 1

Table 1-6-2

mechanical application	lower limit of load	limit of f_s
general industry machines	General Load Condition	1.0~1.3
	Under vibration and shock	2.0~3.0
machine tool	General Load Condition	1.0~1.5
	Under vibration and shock	2.5~7.0

1-6-4 Basic Dynamic Load Rating (C)

Even products manufactured in the same batch will show slight variations in their lifespan when operated under identical conditions. Therefore, to determine the lifespan of linear guides, the following defined rated lifespan is generally used.

The rated lifespan (L) refers to the total operating distance that linear guides of the same specifications can travel under identical conditions, where 90% of them do not exhibit surface fatigue spalling. When linear guides are subjected to loads and in motion, the basic dynamic load rating (C) must be used to calculate their lifespan.

The basic rated load (C) refers to a load with constant direction and magnitude, where a group of linear guides of the same specifications, under identical conditions, achieve a rated life of 50,000 km when steel balls are used as rolling elements, and 100,000 km when rollers are used as rolling elements.

1-6-5 Calculation of service life (L)

The rated life (L) of linear guides varies depending on the actual load they bear and can be calculated based on the basic dynamic load rating (C) and operating load (P) selected.

The service life of linear guides will vary with motion conditions, hardness of the rolling surfaces, and ambient temperature.

Depending on the type of rolling elements in the cycle, use the following formula to calculate its life.

$$\text{Steel 鋼珠 } L = \left(\frac{f_H \times f_T}{f_w} \times \frac{C}{P} \right)^3 \times 50$$

$$\text{Roller 滾柱 } L = \left(\frac{f_H \times f_T}{f_w} \times \frac{C}{P} \right)^{\frac{10}{3}} \times 100$$

L Rated Life (km)
 C Basic Rated Dynamic Load (N)
 P Operating Load (N)
 f_H Hardness Coefficient
 f_T Temperature Coefficient
 f_w Load Coefficient

Formula II

1-6-6 Hardness coefficient (f_H)

The hardness of the rolling surface of the linear guide must be HRC58-64. If the hardness values are below the specified range, it will reduce the load capacity of the linear guide. In such cases, the basic rated static and dynamic loads should be multiplied by the corresponding hardness factor f_H, as shown in the figure below.

The hardness requirement for SHAC linear guide rails at the factory is HRC 58-62, so f_H = 1.0.

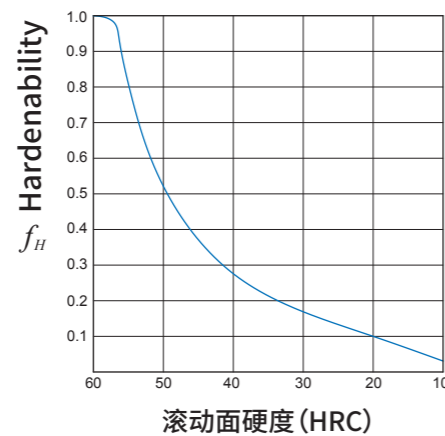

Figure 1-6-2 Rolling Surface Hardness (HRC)

1-6-7 Temperature coefficient (f_T)

Linear guideways operating in environments with temperatures exceeding 100°C will have their service life affected by high-temperature effects. At this temperature, the basic rated dynamic and static loads should be multiplied by the corresponding temperature coefficients f_T, as shown in the figure above.

The components of the SHAC linear guide rail are made of plastic-rubber products, with a recommended operating temperature below 100°C.

If there are any other special requirements, please contact SHAC.

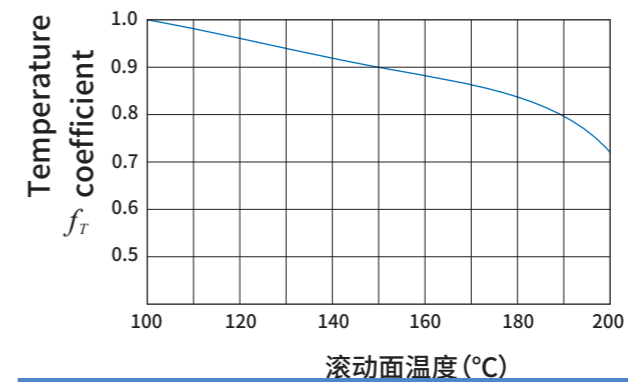

Figure 1-6-3 Rolling Surface temperature (°C)

1-6-8 Load coefficient (f_w)

Although the loads on linear guides can be calculated, actual operation often involves vibration or impact, resulting in loads typically exceeding calculated values. Therefore, when considering different operating conditions and usage speeds, it is recommended to divide the load factor obtained from experience by the basic dynamic load rating C, as shown in the following table.

Table 1-6-3

Operating conditions	Usage speed	f _w
Smooth and impact-free	V ≤ 15m/min	1.0~1.2
Ordinary impact force and vibration	15 < V ≤ 60m/min	1.2~1.5
Moderate impact force and vibration	60 < V ≤ 120m/min	1.5~2.0
Severe impact force and vibration	V ≥ 120m/min	2.0~3.5

Life Calculation (L)

The rated life (L) of linear guides varies depending on the actual load they bear and can be calculated using the basic rated dynamic load (C) and operating load (P) selected for specifications.

The service life of linear guides changes with motion conditions, hardness of the rolling surfaces, and ambient temperature.

Depending on the type of rolling elements in the cycle, their life is calculated using the following formula.

1-6-9 Life Calculation (Lh)

When the travel length and reciprocating frequency of linear guide rails are fixed, the service life (L_h) can be calculated by converting the rated life (L) obtained from the previously mentioned formula.

$$L_h = \frac{L \times 10^3}{2 \times l_s \times n_1 \times 60}$$

L_h 寿命時間(h) (Service life) (h)
 L 額定寿命距離計算值(km) (Rated Value) (km)
 l_s 行程長度(mm) (Stroke length) (mm)
 n_1 毎分往復次數(回) (Reciprocating frequency) (min⁻¹)

Formula III

1-7 E. Slider Load Calculation

- ◎ Calculate the maximum equivalent load of a single slider based on the load calculation example.
- ◎ Confirm that the static safety factor selected for the linear guide exceeds the value listed in the static safety factor usage table

1-7-1 Single slider bears load

The load acting on linear guide rails varies due to factors such as the position of the object's center of gravity, the thrust location, and inertial forces generated by acceleration/deceleration during startup/stoppage.

Therefore, when selecting linear guide rails, various operating conditions must be considered to accurately calculate the working load.

Table 1-7-1

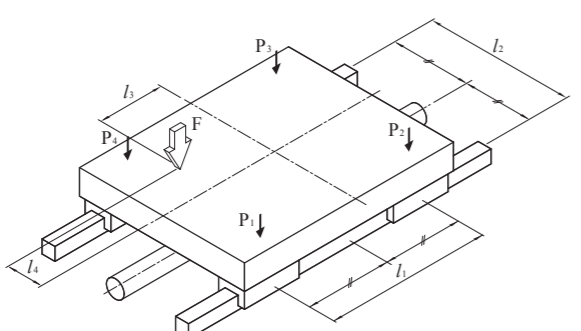
Type	Use configuration	Slider Load Formula
When using horizontally at constant speed motion or when stationary		$P_1 = \frac{F}{4} + \frac{F \cdot l_3}{2 \cdot l_1} - \frac{F \cdot l_4}{2 \cdot l_2}$ $P_2 = \frac{F}{4} - \frac{F \cdot l_3}{2 \cdot l_1} - \frac{F \cdot l_4}{2 \cdot l_2}$ $P_3 = \frac{F}{4} - \frac{F \cdot l_3}{2 \cdot l_1} + \frac{F \cdot l_4}{2 \cdot l_2}$ $P_4 = \frac{F}{4} + \frac{F \cdot l_3}{2 \cdot l_1} + \frac{F \cdot l_4}{2 \cdot l_2}$

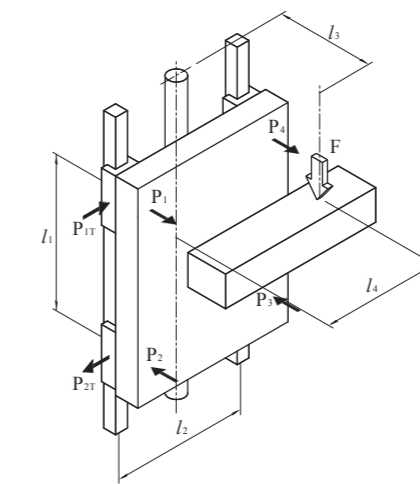
Type	Use configuration	Slider Load Formula
Vertical use during constant speed motion or when stationary		$P_1 = P_2 = P_3 = P_4 = \frac{F \cdot l_3}{2 \cdot l_1}$ $P_{1T} = P_{2T} = P_{3T} = P_{4T} = \frac{F \cdot l_4}{2 \cdot l_1}$

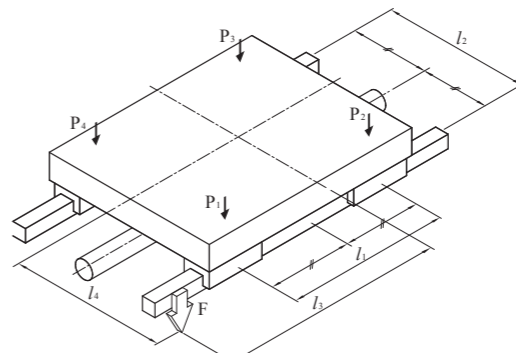
Type	Use configuration	Slider Load Formula
Horizontal cantilever used in constant speed motion or when stationary		$P_1 = \frac{F}{4} + \frac{F \cdot l_3}{2 \cdot l_1} + \frac{F \cdot l_4}{2 \cdot l_2}$ $P_2 = \frac{F}{4} - \frac{F \cdot l_3}{2 \cdot l_1} + \frac{F \cdot l_4}{2 \cdot l_2}$ $P_3 = \frac{F}{4} - \frac{F \cdot l_3}{2 \cdot l_1} - \frac{F \cdot l_4}{2 \cdot l_2}$ $P_4 = \frac{F}{4} + \frac{F \cdot l_3}{2 \cdot l_1} - \frac{F \cdot l_4}{2 \cdot l_2}$

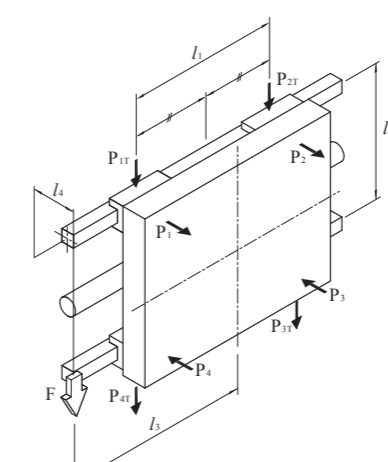
Type	Use configuration	Slider Load Formula
When using the suspension in constant speed motion or at rest		$P_1 = P_2 = P_3 = P_4 = \frac{F \cdot l_4}{2 \cdot l_2}$ $P_{1T} = P_{4T} = \frac{F}{4} + \frac{F \cdot l_3}{2 \cdot l_1}$ $P_{2T} = P_{3T} = \frac{F}{4} - \frac{F \cdot l_3}{2 \cdot l_1}$

Type	Use configuration	Slider Load Formula
Side Tilted Use		$P_1 = \frac{F \cdot \cos\theta}{4} + \frac{F \cdot \cos\theta \cdot l_3}{2 \cdot l_1} - \frac{F \cdot \cos\theta \cdot l_4}{2 \cdot l_2} + \frac{F \cdot \sin\theta \cdot h_1}{2 \cdot l_2}$ $P_2 = \frac{F \cdot \cos\theta}{4} - \frac{F \cdot \cos\theta \cdot l_3}{2 \cdot l_1} - \frac{F \cdot \cos\theta \cdot l_4}{2 \cdot l_2} + \frac{F \cdot \sin\theta \cdot h_1}{2 \cdot l_2}$ $P_3 = \frac{F \cdot \cos\theta}{4} - \frac{F \cdot \cos\theta \cdot l_3}{2 \cdot l_1} + \frac{F \cdot \cos\theta \cdot l_4}{2 \cdot l_2} - \frac{F \cdot \sin\theta \cdot h_1}{2 \cdot l_2}$ $P_4 = \frac{F \cdot \cos\theta}{4} + \frac{F \cdot \cos\theta \cdot l_3}{2 \cdot l_1} + \frac{F \cdot \cos\theta \cdot l_4}{2 \cdot l_2} - \frac{F \cdot \sin\theta \cdot h_1}{2 \cdot l_2}$ $P_{1r} = P_{2r} = \frac{F \cdot \sin\theta}{4} + \frac{F \cdot \sin\theta \cdot l_3}{2 \cdot l_1}$ $P_{2r} = P_{3r} = \frac{F \cdot \sin\theta}{4} - \frac{F \cdot \sin\theta \cdot l_3}{2 \cdot l_1}$

Usage Conditions

GHW35HC2R2520ZAP

Basic Dynamic Load Rating: C=76.73kN

Basic Dynamic Load Rating: C₀=120.93kN

Mass	m ₁ = 700 kg m ₂ = 450 kg	Route	l ₅ = 1500 mm
Velocity	V = 0.75 m/s	Distance	l ₁ = 650 mm l ₂ = 450 mm l ₃ = 135 mm l ₄ = 60 mm l ₅ = 175 mm l ₆ = 400 mm
Time	t ₁ = 0.05 s t ₂ = 1.9 s t ₃ = 0.15 s		
Acceleration	a ₁ = 15 m/s ² a ₃ = 5 m/s ²		

Type	Use configuration	Slider Load Formula
Front-tilted use		$P_1 = \frac{F \cdot \cos\theta}{4} + \frac{F \cdot \cos\theta \cdot l_3}{2 \cdot l_1} - \frac{F \cdot \cos\theta \cdot l_4}{2 \cdot l_2} + \frac{F \cdot \sin\theta \cdot h_1}{2 \cdot l_1}$ $P_2 = \frac{F \cdot \cos\theta}{4} - \frac{F \cdot \cos\theta \cdot l_3}{2 \cdot l_1} - \frac{F \cdot \cos\theta \cdot l_4}{2 \cdot l_2} + \frac{F \cdot \sin\theta \cdot h_1}{2 \cdot l_1}$ $P_3 = \frac{F \cdot \cos\theta}{4} - \frac{F \cdot \cos\theta \cdot l_3}{2 \cdot l_1} + \frac{F \cdot \cos\theta \cdot l_4}{2 \cdot l_2} - \frac{F \cdot \sin\theta \cdot h_1}{2 \cdot l_1}$ $P_4 = \frac{F \cdot \cos\theta}{4} + \frac{F \cdot \cos\theta \cdot l_3}{2 \cdot l_1} + \frac{F \cdot \cos\theta \cdot l_4}{2 \cdot l_2} + \frac{F \cdot \sin\theta \cdot h_1}{2 \cdot l_1}$ $P_{1r} = P_{2r} = + \frac{F \cdot \sin\theta \cdot l_4}{2 \cdot l_1}$ $P_{2r} = P_{3r} = - \frac{F \cdot \sin\theta \cdot l_4}{2 \cdot l_1}$

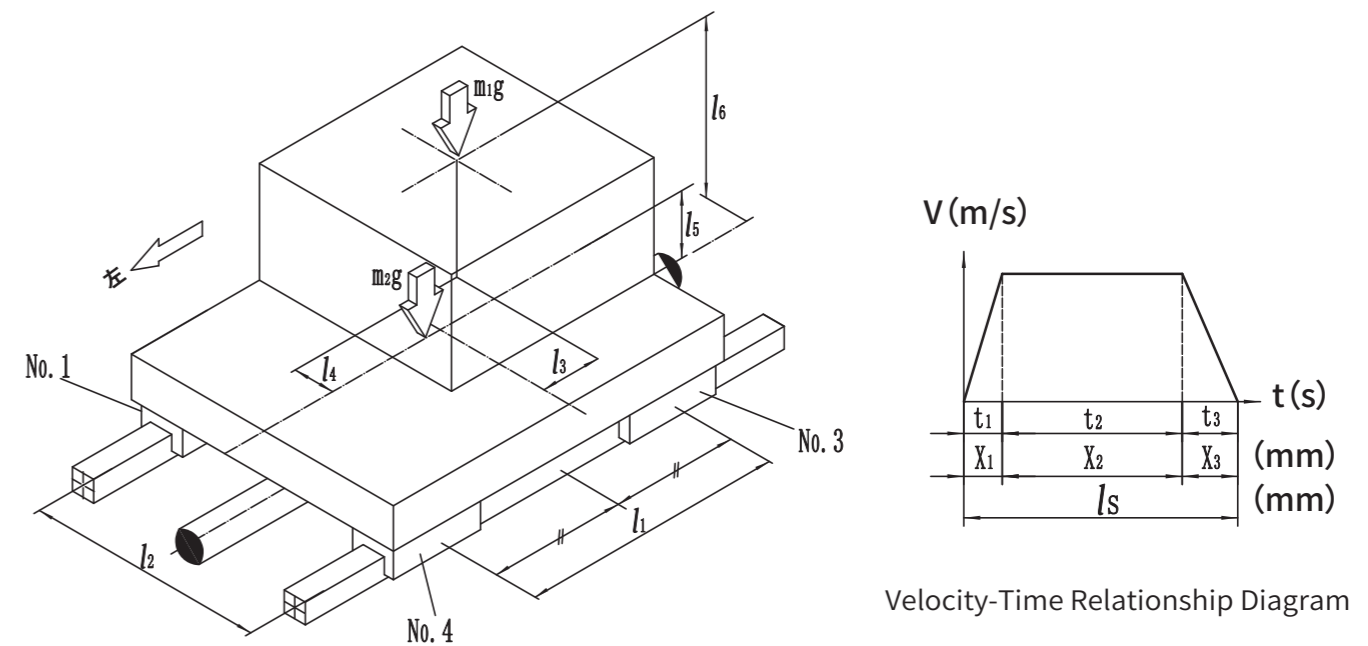

Figure 1-7-1

Calculation of the magnitude of each slider load

Radial load magnitude Pnlat constant speed

$$P_1 = \frac{m_1 g}{4} - \frac{m_1 g \cdot l_3}{2l_1} + \frac{m_1 g \cdot l_4}{2l_2} + \frac{m_2 g}{4}$$

$$= 2562.4 \text{ N}$$

$$P_2 = \frac{m_1 g}{4} + \frac{m_1 g \cdot l_3}{2l_1} + \frac{m_1 g \cdot l_4}{2l_2} + \frac{m_2 g}{4}$$

$$= 3987.2 \text{ N}$$

$$P_3 = \frac{m_1 g}{4} + \frac{m_1 g \cdot l_3}{2l_1} - \frac{m_1 g \cdot l_4}{2l_2} + \frac{m_2 g}{4}$$

$$= 3072.6 \text{ N}$$

$$P_4 = \frac{m_1 g}{4} - \frac{m_1 g \cdot l_3}{2l_1} - \frac{m_1 g \cdot l_4}{2l_2} + \frac{m_2 g}{4}$$

$$= 1647.8 \text{ N}$$

During leftward acceleration, the magnitude of the radial load Pnla1

$$P_1 la_1 = P_1 - \frac{m_1 \cdot a_1 \cdot l_6}{2l_1} - \frac{m_2 \cdot a_1 \cdot l_5}{2l_1}$$

$$= -1577 \text{ N}$$

$$P_2 la_1 = P_2 + \frac{m_1 \cdot a_1 \cdot l_6}{2l_1} + \frac{m_2 \cdot a_1 \cdot l_5}{2l_1}$$

$$= 8126.6 \text{ N}$$

$$P_3 la_1 = P_3 + \frac{m_1 \cdot a_1 \cdot l_6}{2l_1} + \frac{m_2 \cdot a_1 \cdot l_5}{2l_1}$$

$$= 7212 \text{ N}$$

$$P_4 la_1 = P_4 - \frac{m_1 \cdot a_1 \cdot l_6}{2l_1} - \frac{m_2 \cdot a_1 \cdot l_5}{2l_1}$$

$$= -2491.6 \text{ N}$$

Lateral load magnitude $P_{t_n} la_1$

$$P_{t_1} la_1 = -\frac{m_1 \cdot a_1 \cdot l_4}{2l_1} = -484.6 \text{ N}$$

$$P_{t_3} la_1 = \frac{m_1 \cdot a_1 \cdot l_4}{2l_1} = 484.6 \text{ N}$$

$$P_{t_2} la_1 = \frac{m_1 \cdot a_1 \cdot l_4}{2l_1} = 484.6 \text{ N}$$

$$P_{t_4} la_1 = -\frac{m_1 \cdot a_1 \cdot l_4}{2l_1} = -484.6 \text{ N}$$

During left deceleration, the radial load size Pnla3

$$P_1 la_3 = P_1 + \frac{m_1 \cdot a_3 \cdot l_6}{2l_1} + \frac{m_2 \cdot a_3 \cdot l_5}{2l_1}$$

$$= 3942.2 \text{ N}$$

$$P_2 la_3 = P_2 - \frac{m_1 \cdot a_3 \cdot l_6}{2l_1} - \frac{m_2 \cdot a_3 \cdot l_5}{2l_1}$$

$$= 2607.4 \text{ N}$$

$$P_3 la_3 = P_3 - \frac{m_1 \cdot a_3 \cdot l_6}{2l_1} - \frac{m_2 \cdot a_3 \cdot l_5}{2l_1}$$

$$= 1692.8 \text{ N}$$

$$P_4 la_3 = P_4 + \frac{m_1 \cdot a_3 \cdot l_6}{2l_1} + \frac{m_2 \cdot a_3 \cdot l_5}{2l_1}$$

$$= 3027.6 \text{ N}$$

Lateral load magnitude $P_{t_n} la_3$

$$P_{t_1} la_3 = \frac{m_1 \cdot a_3 \cdot l_4}{2l_1} = 161.5 \text{ N}$$

$$P_{t_3} la_3 = -\frac{m_1 \cdot a_3 \cdot l_4}{2l_1} = -161.5 \text{ N}$$

$$P_{t_2} la_3 = -\frac{m_1 \cdot a_3 \cdot l_4}{2l_1} = -161.5 \text{ N}$$

$$P_{t_4} la_3 = \frac{m_1 \cdot a_3 \cdot l_4}{2l_1} = 161.5 \text{ N}$$

Rightward acceleration: radial load magnitude Pnla1

$$P_1 ra_1 = P_1 + \frac{m_1 \cdot a_1 \cdot l_6}{2l_1} + \frac{m_2 \cdot a_1 \cdot l_5}{2l_1}$$

$$= 6701.8 \text{ N}$$

$$P_2 ra_1 = P_2 - \frac{m_1 \cdot a_1 \cdot l_6}{2l_1} - \frac{m_2 \cdot a_1 \cdot l_5}{2l_1}$$

$$= -152.2 \text{ N}$$

$$P_3 ra_1 = P_3 - \frac{m_1 \cdot a_1 \cdot l_6}{2l_1} - \frac{m_2 \cdot a_1 \cdot l_5}{2l_1}$$

$$= -1066.8 \text{ N}$$

$$P_4 ra_1 = P_4 + \frac{m_1 \cdot a_1 \cdot l_6}{2l_1} + \frac{m_2 \cdot a_1 \cdot l_5}{2l_1}$$

$$= 5787.2 \text{ N}$$

Lateral load magnitude $P_{t_n} ra_1$

$$P_{t_1} ra_1 = \frac{m_1 \cdot a_1 \cdot l_4}{2l_1} = 484.6 \text{ N}$$

$$P_{t_2} ra_1 = -\frac{m_1 \cdot a_1 \cdot l_4}{2l_1} = -484.6 \text{ N}$$

$$P_{t_3} ra_1 = -\frac{m_1 \cdot a_1 \cdot l_4}{2l_1} = -484.6 \text{ N}$$

$$P_{t_4} ra_1 = \frac{m_1 \cdot a_1 \cdot l_4}{2l_1} = 484.6 \text{ N}$$

During right-side deceleration, radial load size Pnla3

$$P_1 ra_3 = P_1 - \frac{m_1 \cdot a_3 \cdot l_6}{2l_1} - \frac{m_2 \cdot a_3 \cdot l_5}{2l_1}$$

$$= 1182.6 \text{ N}$$

$$P_2 ra_3 = P_2 + \frac{m_1 \cdot a_3 \cdot l_6}{2l_1} + \frac{m_2 \cdot a_3 \cdot l_5}{2l_1}$$

$$= 5367 \text{ N}$$

$$P_3 ra_3 = P_3 + \frac{m_1 \cdot a_3 \cdot l_6}{2l_1} + \frac{m_2 \cdot a_3 \cdot l_5}{2l_1}$$

$$= 4452.4 \text{ N}$$

$$P_4 ra_3 = P_4 - \frac{m_1 \cdot a_3 \cdot l_6}{2l_1} - \frac{m_2 \cdot a_3 \cdot l_5}{2l_1}$$

$$= 268 \text{ N}$$

Lateral load magnitude $P_{t_n} ra_3$

$$P_{t_1} ra_3 = -\frac{m_1 \cdot a_3 \cdot l_4}{2l_1} = -161.5 \text{ N}$$

$$P_{t_2} ra_3 = \frac{m_1 \cdot a_3 \cdot l_4}{2l_1} = 161.5 \text{ N}$$

$$P_{t_3} ra_3 = \frac{m_1 \cdot a_3 \cdot l_4}{2l_1} = 161.5 \text{ N}$$

$$P_{t_4} ra_3 = -\frac{m_1 \cdot a_3 \cdot l_4}{2l_1} = -161.5 \text{ N}$$

1-7-2 Inertia load

Table 1-7-2

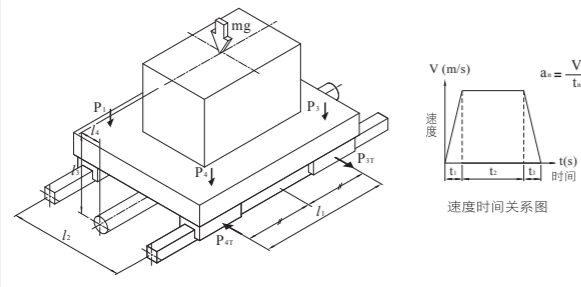
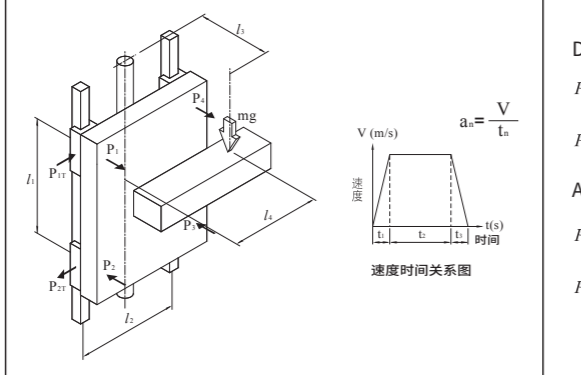
Type	Use configuration	Slider Load Formula
Horizontal use of water subjected to inertial forces		<p>During acceleration</p> $P_1 = P_4 = \frac{mg}{4} - \frac{m a_j l_3}{2 l_1}$ $P_2 = P_3 = \frac{mg}{4} + \frac{m a_j l_3}{2 l_1}$ $P_{1r} = P_{2r} = P_{3r} = P_{4r} = \frac{m a_j l_4}{2 l_1}$ <p>During deceleration</p> $P_1 = P_4 = \frac{mg}{4} + \frac{m a_j l_3}{2 l_1}$ $P_2 = P_3 = \frac{mg}{4} - \frac{m a_j l_3}{2 l_1}$ $P_{1r} = P_{2r} = P_{3r} = P_{4r} = \frac{m a_j l_4}{2 l_1}$ <p>At constant speed</p> $P_1 = P_2 = P_3 = P_4 = \frac{mg}{4}$
Vertical use with inertial force acting on it		<p>During acceleration</p> $P_1 = P_2 = P_3 = P_4 = \frac{m(g+a_j)l_3}{2 l_1}$ $P_{1r} = P_{2r} = P_{3r} = P_{4r} = \frac{m(g+a_j)l_4}{2 l_1}$ <p>During deceleration</p> $P_1 = P_2 = P_3 = P_4 = \frac{m(g-a_j)l_3}{2 l_1}$ $P_{1r} = P_{2r} = P_{3r} = P_{4r} = \frac{m(g-a_j)l_4}{2 l_1}$ <p>At constant speed</p> $P_1 = P_2 = P_3 = P_4 = \frac{m g l_3}{2 l_1}$ $P_{1r} = P_{2r} = P_{3r} = P_{4r} = \frac{m g l_4}{2 l_1}$

1-7-3 Equivalent load in two directions

SHAC linear guide rail can withstand loads in four directions: up, down, left, and right.

When using the linear guide rail, it may be subjected to both vertical direction load (P_s) and lateral direction load (P_l) simultaneously.

The equivalent load (P_e) can be calculated using the following formula.

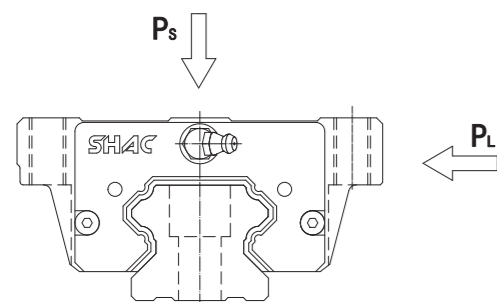

Figure 1-7-2

$$\begin{aligned} \text{GM, GW} \quad & \text{When } P_s > P_l \quad P_e = P_s + 0.5 \cdot P_l \\ \text{GH, GE, GR} \quad & \text{When } P_l > P_s \quad P_e = P_l + 0.5 \cdot P_s \end{aligned}$$

Formula IV

Table 1-7-3

Item	Use conditional settings	Corresponding explanation	Suggested Solution
1	Equivalent Load	The linear rail system can withstand all normal loads and moment loads (M_r , M_p , M_y), including simultaneous radial, counter-radial, and lateral loads.	Table 1-3 (F at different positions)
2	Static safety factor	The static safety factor is expressed as the multiple of the load applied to the linear guide, denoted by f_s .	Page 14, Table 1

Equivalent Load Calculation

Constant speed condition

$$P_{E1} = P_1 = 2562.4 \text{ N}$$

$$P_{E3} = P_3 = 3072.6 \text{ N}$$

左行加速时

$$P_{E2} = P_2 = 3987.2 \text{ N}$$

$$P_{E4} = P_4 = 1647.8 \text{ N}$$

Leftward Acceleration Status

$$P_{E1} l_{a1} = |P_1 l_{a1}| + |P_{t1} l_{a1}| = 2061.6 \text{ N}$$

$$P_{E3} l_{a1} = |P_3 l_{a1}| + |P_{t3} l_{a1}| = 7696.6 \text{ N}$$

左行减速时

$$P_{E2} l_{a1} = |P_2 l_{a1}| + |P_{t2} l_{a1}| = 8611.2 \text{ N}$$

$$P_{E4} l_{a1} = |P_4 l_{a1}| + |P_{t4} l_{a1}| = 2976.2 \text{ N}$$

Left turn deceleration state

右行加速时

$$P_{E1} l_{a3} = |P_1 l_{a3}| + |P_{t1} l_{a3}| = 4103.7 \text{ N}$$

$$P_{E3} l_{a3} = |P_3 l_{a3}| + |P_{t3} l_{a3}| = 1854.3 \text{ N}$$

$$P_{E2} l_{a3} = |P_2 l_{a3}| + |P_{t2} l_{a3}| = 2768.9 \text{ N}$$

$$P_{E4} l_{a3} = |P_4 l_{a3}| + |P_{t4} l_{a3}| = 3189.1 \text{ N}$$

Rightward Acceleration State

右行减速时

$$P_{E1} r_{a1} = |P_1 r_{a1}| + |P_{t1} r_{a1}| = 7186.4 \text{ N}$$

$$P_{E3} r_{a1} = |P_3 r_{a1}| + |P_{t3} r_{a1}| = 1551.4 \text{ N}$$

$$P_{E2} r_{a1} = |P_2 r_{a1}| + |P_{t2} r_{a1}| = 636.8 \text{ N}$$

$$P_{E4} r_{a1} = |P_4 r_{a1}| + |P_{t4} r_{a1}| = 6271.8 \text{ N}$$

Right turn deceleration state

$$P_{E1} r_{a3} = |P_1 r_{a3}| + |P_{t1} r_{a3}| = 1344.1 \text{ N}$$

$$P_{E3} r_{a3} = |P_3 r_{a3}| + |P_{t3} r_{a3}| = 4613.9 \text{ N}$$

$$P_{E2} r_{a3} = |P_2 r_{a3}| + |P_{t2} r_{a3}| = 5528.5 \text{ N}$$

$$P_{E4} r_{a3} = |P_4 r_{a3}| + |P_{t4} r_{a3}| = 429.5 \text{ N}$$

Static Safety Factor Calculation

From Item 2, it is known that the maximum equivalent load occurs during the leftward acceleration of the NO.2 slider, so the safety factor can be calculated by the formula.

$$f_s = \frac{C_o}{P_{E2} l_{a1}} = \frac{120.93 \times 10^3}{8611.2} = 14.04$$

The calculation of average load for each slider, Pmm

$$P_{m1} = \sqrt[3]{\frac{(P_{E1}la_1^3 \cdot X_1 + P_{E1}^3 \cdot X_2 + P_{E1}la_3^3 \cdot X_3 + P_{E1}ra_1^3 \cdot X_1 + P_{E1}^3 \cdot X_2 + P_{E1}ra_3^3 \cdot X_3)}{2l_s}} = 2700.7 \text{ N}$$

$$P_{m2} = \sqrt[3]{\frac{(P_{E2}la_1^3 \cdot X_1 + P_{E2}^3 \cdot X_2 + P_{E2}la_3^3 \cdot X_3 + P_{E2}ra_1^3 \cdot X_1 + P_{E2}^3 \cdot X_2 + P_{E2}ra_3^3 \cdot X_3)}{2l_s}} = 4077.2 \text{ N}$$

$$P_{m3} = \sqrt[3]{\frac{(P_{E3}la_1^3 \cdot X_1 + P_{E3}^3 \cdot X_2 + P_{E3}la_3^3 \cdot X_3 + P_{E3}ra_1^3 \cdot X_1 + P_{E3}^3 \cdot X_2 + P_{E3}ra_3^3 \cdot X_3)}{2l_s}} = 3187.7 \text{ N}$$

$$P_{m4} = \sqrt[3]{\frac{(P_{E4}la_1^3 \cdot X_1 + P_{E4}^3 \cdot X_2 + P_{E4}la_3^3 \cdot X_3 + P_{E4}ra_1^3 \cdot X_1 + P_{E4}^3 \cdot X_2 + P_{E4}ra_3^3 \cdot X_3)}{2l_s}} = 1872.6 \text{ N}$$

Calculation of Rated Life L

According to the rated life calculation formula for linear guide rails, assuming $f=1.5$, the results are as follows:

$$L_1 = \left(\frac{C}{f_w \cdot P_{m1}} \right)^3 \times 50 = 339753 \text{ km}$$

$$L_3 = \left(\frac{C}{f_w \cdot P_{m3}} \right)^3 \times 50 = 206614 \text{ km}$$

$$L_2 = \left(\frac{C}{f_w \cdot P_{m2}} \right)^3 \times 50 = 98743 \text{ km}$$

$$L_4 = \left(\frac{C}{f_w \cdot P_{m4}} \right)^3 \times 50 = 1019194 \text{ km}$$

Based on the above, the linear rails used in the equipment under these operating conditions have a lifespan of 56,231 km for No.2 slider.

1-7-4 Selection of the static safety factor

Table 1-7-4

load condition	lower limit of $f_1 f_2$
General Operating Status	1.0~3.0
Subject to impact and vibration during operation	3.0~5.0

f_{SL} f_{SM}

$$f_{SL} = \frac{C_0}{P} \text{ or } f_{SM} = \frac{M_0}{M}$$

静安全系数

Formula V

基本静额定负荷 (kN)

f_1 : Factor of safety (静安全系数)

f_2 : Basic Safety Factor (基本安全系数)

C_0 : Rated Load (静力额定负荷 (kN·m))

M_0 : Permissible Load (kN·m)

P: Working Load

M: Torque Load (kN·m)

1-8 F. Pre-compression Installation Accuracy

© Select based on rigidity requirements and installation surface precision

Preloading refers to the process of increasing the diameter of steel balls to create a negative clearance between the steel balls and the groove, thereby applying a pre-applied internal load.

The use of preloading not only eliminates clearance but also enhances the rigidity and positional accuracy of the slider.

The preload is a predetermined force applied to the steel balls, achieved by enlarging their diameter to generate a negative clearance between the balls and the groove.

This method improves the rigidity of linear guide rails and eliminates clearance.

As illustrated in the diagram, increasing the preload enhances the rigidity of linear sliders.

However, for small-sized applications, it is recommended to select preloads below the light preload level to avoid excessive preloading that could shorten the lifespan of the components.

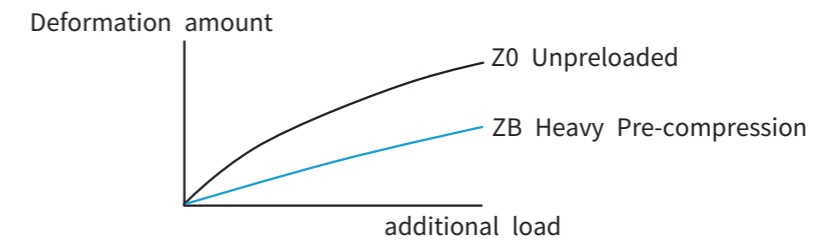

Figure V

Table 1-8-1

Item	Use conditional settings	Corresponding explanation	Suggested Solution
1	Rigid requirements	Rigidity refers to the degree of deformation of a material or structure after being subjected to force	Page 17 , Table2-1-8
2	Installation surface precision	The auto-centering characteristic of the steel ball slider can absorb some installation errors	Page 25, Table 2-1-24

Installation Flatness Error

The GH series are arc-shaped two-point contact linear slide rails with auto-leveling characteristics that can absorb minor deviations on the installation surface without affecting the smoothness of linear motion.

The permissible tolerance values of the installation surface are noted in the table below.

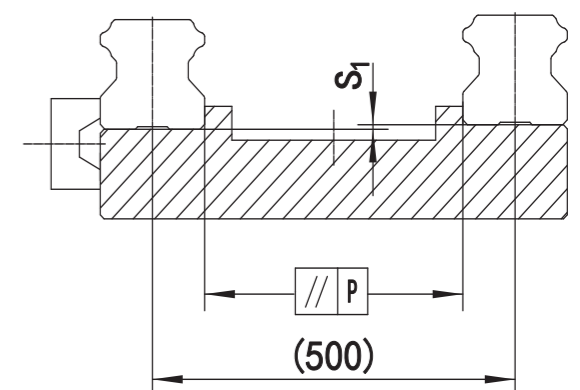

Figure 5

GH Series Linear Guide Rails Offer Three Standard Preloads, Which Can Be Selected Based on Application Requirements to Choose Appropriate Preload Forces

Table 1-8-2

Grade of preload	Mark	Preload	Usage Conditions	Application Scope
Unpreloaded	Z0	0~0.02C	Load is reverse fixed with low impact force and low precision requirement	Handling automated equipment requires structural components with lightweight, swift linear motion and other similar components
Light preload	ZA	0.02C~0.04C	Light load and requires high precision	Large precision CNC machines, such as: Gantry milling machines, Vertical and horizontal lathes, etc
Medial preload	ZB	0.04C~0.08C	Rigid requirements, subject to vibration and impact operating environment	Precision general-purpose CNC machine tools, such as: CNC Machining Centers, Multi-axis Machining Centers
	ZC	0.08C~0.12C		
Grade	Compatibility Linear Rail (Single shipment item)			
Code of preload	Z0、ZA			Z0、ZA、ZB

1-9 G. Rigid Deformation Confirmation

- ◎ Calculate deformation based on the stiffness table
- ◎ Increase preload, use a larger size or add more sliders to enhance stiffness

The stiffness of a guide rail refers to its ability to deform under load. Stiffness is crucial for maintaining the accuracy and stability of a mechanical system. The calculation of stiffness involves factors such as the material properties and geometric shape of the guide rail. Based on actual requirements, the stiffness of the guide rail can be calculated.

Table 1-9-1

Item	Use conditional settings	Corresponding explanation	Suggested Solution
1	Deformation amount	Rated dynamic and static load	Page 115
2	Increase pre-load (stiffness)	Material, structure, clearance, preload	Page 175 Table 1-8-2
3	Increase the size	After increasing the specifications of the linear guide rail, the static load increases accordingly	Page 46
4	Increase quantity	Increasing the number of sliders in equivalent load calculations improves the load-bearing capacity	

1-9-1 Rigidity Calculation Formula in Mechanics of Materials

In the fields of material mechanics and mechanical engineering, the quantification formula for rigidity (or stiffness) is

Basic Definition: Stiffness $K=F/\delta$ (the ratio of load to deformation)

F: is the applied load (unit: N).

δ : is the resulting elastic deformation (unit: mm or μm).

The unit is typically N/mm or N/ μm . For example, the stiffness values of a machine tool lead screw system typically range from 50 to 200 N/ μm .

Application Scenario:

Static Rigidity: Used to calculate the deflection of a machine tool under cutting forces (e.g., three-axis deflection $\delta x = Fx/Kx$).

Dynamic Rigidity: No direct formula exists, but it is indirectly evaluated through parameters such as natural frequency, bearing type (roller bearings exhibit superior dynamic rigidity compared to ball bearings).

1-9-2 Linear Guide Rail Rigidity Calculation

The rigidity of linear guide rails primarily depends on the following factors:

Preload: Achieved by adjusting the steel ball diameter, categorized into three levels: no preload (light preload), medium preload, and heavy preload. Greater preload enhances rigidity but reduces lifespan accordingly.

Rail Type: Wider rails improve static allowable torque by over 100% compared to standard rails, significantly enhancing rigidity.

Load Direction: Different load directions affect rigidity differently; equivalent static load calculations are required for accurate assessment.

Rigid Calculation Method

Static Allowable Torque Calculation: Refers to the maximum torque that the guide rail can withstand without causing plastic deformation or failure.

Preload Selection:

No Preload/Light Preload: Applications with fixed load direction, minimal impact, and low precision requirements.

Moderate Preload: Suitable for light loads requiring high precision.

Heavy Preload: Required for environments with rigidity demands and vibrations/impacts.

Application Recommendations:

For height-constrained scenarios, use widened rails with a height-to-width ratio of approximately 0.65 (standard rails have a ratio of ~1.1), achieving 40% reduced total height while enhancing rigidity.

For offset structures, widened rails demonstrate more pronounced static allowable torque enhancement.

In high rigidity requirement scenarios (such as grinding machines and milling machines), select heavy preloaded types.

When the steel ball in the slider, which is subjected to maximum pressure, reaches the static rated load as defined above, the torque borne by the slider at this point is termed the static rated torque. In linear rail motion, this is defined along three directions: MR, Mp, and My

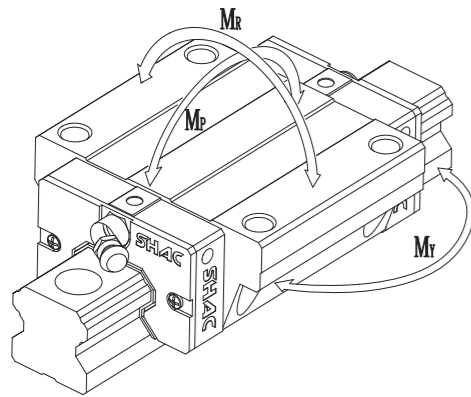

Figure 1-9-1

Reference date:

1-7-3 Equivalent load in two directions

SHAC linear guide rail can withstand loads in four directions: up, down, left, and right.

When using the linear guide rail, it may be subjected to both vertical direction load (Ps) and lateral direction load (Pl) simultaneously.

The equivalent load (Pe) can be calculated using the following formula.

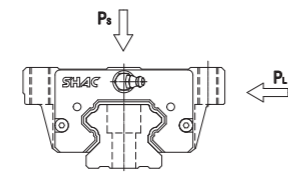

Figure 1-7-2

$$\begin{aligned} & \text{GM,GW} \quad \text{When } P_s > P_l \quad P_e = P_s + 0.5 \cdot P_l \\ & \text{GH,GE,GR} \quad P_e = P_s + P_l \quad \text{When } P_l > P_s \quad P_e = P_l + 0.5 \cdot P_s \end{aligned}$$

Formula IV

Selection of the static safety factor

Table 1-9-4

load condition	lower limit of f1f2
General Operating Status	1.0~3.0
Subject to impact and vibration during operation	3.0~5.0

$$f_{SL} = \frac{C_0}{P} \quad \text{or} \quad f_{SM} = \frac{M_0}{M}$$

Formula V

f₁: Factor of Safety (Torque Load)

f₂: Basic Safety Factor

C₀: Rated Load

M₀: Permissible Load (kN · m)

P: Working Load

M: Torque Load (kN · m)

1-10 H. Service Life Calculation

左行加速时

◎ According to speed frequency to calculate service life distance requirements

左行減速时

◎ Calculate the service life distance of the selected linear guide rails using the service life formula

右行加速时

◎ Theoretical service life length, theoretical service life time

右行減速时

Table 1-10-1

Item	Use conditional settings	Corresponding explanation	Suggested Solution
1	Usage Speed	Displacement speed per minute	
2	Usage Frequency	Operational rate per day	

Convert nominal lifespan to service life by using speed and frequency

L_n: Service Life (hours)

L: Rated Service Life (miles)

V_e: Speed (meters/minute)

C/P: Load Factor

$$L_n = \frac{L \cdot 10^3}{V_e \cdot 60} = \frac{\left(\frac{C}{P}\right)^3 \cdot 50 \cdot 10^3}{V_e \cdot 60} \text{ hr}$$

Formula VII

Reference date:

1-6-5 Calculation of service life (L)

The rated life (L) of linear guides varies depending on the actual load they bear and can be calculated based on the basic dynamic load rating (C) and operating load (P) selected.

The service life of linear guides will vary with motion conditions, hardness of the rolling surfaces, and ambient temperature.

Depending on the type of rolling elements in the cycle, use the following formula to calculate its life.

$$\text{Steel 鋼珠} \quad L = \left(\frac{f_H \times f_T}{f_W} \times \frac{C}{P} \right)^3 \times 50$$

$$\text{Roller 滾柱} \quad L = \left(\frac{f_H \times f_T}{f_W} \times \frac{C}{P} \right)^{\frac{10}{3}} \times 100$$

L: Rated Life (km)

C: Basic Rated Dynamic Load (N)

P: Operating Load (N)

f_H: Hardness Coefficient

f_T: Temperature Coefficient

f_W: Load Coefficient

Formula II

Reference date:

1-6-9 Life Calculation (Lh)

When the travel length and reciprocating frequency of linear guide rails are fixed, the service life (Lh) can be calculated by converting the rated life (L) obtained from the previously mentioned formula.

$$L_h = \frac{L \times 10^3}{2 \times l_s \times n_1 \times 60}$$

L_h 寿命时间(h)
 L 额定寿命距离计算值(km)
 l_s 行程长度(m)
 n_1 每分钟往复次数(min⁻¹)

Formula III

1-10-1 Calculation of service life

Based on experience, select the type and specification of linear guide rails. Then, estimate the maximum working load of a single slider according to the actual usage situation. Calculate the load ratio between the dynamic rated load and the working load to predict its service life.

Table 1-10-1

Specifications for the use of linear guideways	Device dimensions	processing conditions
Model: GHH30CA	d: 600mm	The weight of the device itself (W): 15kN
C: 38.74kN	c: 400mm	Drilling force (F): 1kN
C0: 52.19kN	h: 200mm	System temperature: Normal temperature
Preload: Z0	l: 250mm	Load status: Normal load

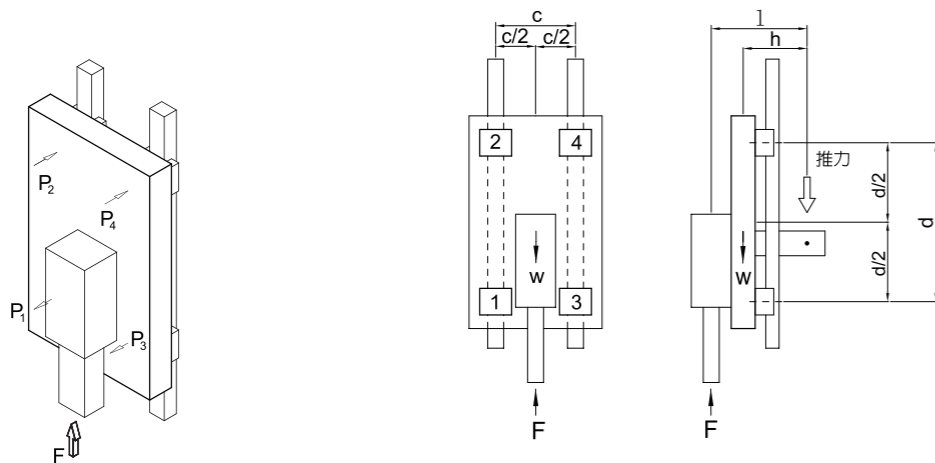

Figure 1-10-1

Formula VIII

滑块承受负荷计算

$$P_1 \sim P_4 = + \frac{W \times h}{2d} - \frac{F \times l}{2d} = + \frac{15 \times 200}{2 \times 600} - \frac{1 \times 250}{2 \times 600} = 2.29(\text{kN})$$

因选用Z0预压, 因此Pc=Pmax=2.29(kN)

注: 若选择较重的预压(ZA、ZB)虽会提升刚性, 但会降低其使用寿命

Calculation of load borne by slider

$$P_1 \sim P_4 = + \frac{W \times h}{2d} - \frac{F \times l}{2d} = + \frac{15 \times 200}{2 \times 600} - \frac{1 \times 250}{2 \times 600} = 2.29(\text{kN})$$

滑块承受负荷计算

因选用Z0预压, 因此Pc=Pmax=2.29(kN)

注: 若选择较重的预压(ZA、ZB)虽会提升刚性, 但会降低其使用寿命

Note: Choosing a heavier preload (ZA, ZB) will enhance rigidity, but it

寿命计算, its service life

因选用Z0预压, 因此Pc=Pmax=2.29(kN)

寿命L计算

$$L = \left(\frac{f_n \times f_r \times C}{f_w \times P_c} \right)^3 \times 50 = \left(\frac{1 \times 1 \times 38.74}{2 \times 2.29} \right)^3 \times 50 = 30,258(\text{km})$$

1-10-2 Friction

Linear guide rails utilize steel balls for rolling guidance, thereby reducing friction to a level comparable to traditional methods 1/50 of sliding guidance, especially with very low static friction and no significant difference in dynamic friction

Due to the difference, there will be no occurrence of slipping or idling, enabling micro-level operation Motion accuracy;

Generally speaking, the friction coefficient of linear guide rails is about 0.004. Among them, scraping The resistance of oil film varies depending on its specifications, and its values are listed in the friction section for each specification.

$$F = \mu \cdot W + S$$

F: Friction force (kN)

S: resistance of oil scraper (kN)

μ : Friction coefficient

W: Load in the vertical direction of motion (kN)

Formula IX

1-11 I Selection of Lubrication Positions

Depending on the equipment requirements, choose lubricating grease, lubricating oil, or special lubricant for lubrication. Regularly inject lubricating grease or use automatic oil supply

If linear guides are not adequately lubricated, the friction of the rolling elements will increase, and over time, this can become the main reason for reducing their lifespan.

The application of the lubric agent provides the following effects:

1. Reduces friction on rolling parts, prevents scuffing, and reduces wear.
2. Forms a lubric film between rolling surfaces, extending the fatigue life of the rolling surfaces.
3. Prevents rust.

$$T = \frac{100 \cdot 1000}{V_e \cdot 60} \text{hr}$$

T: Oil injection frequency (hour)

V_e : Speed (m/min)

Formula IX

1-11-1 Lubricating Grease

Each set of linear guide rails is equipped with a lubrication bead groove rail. Although the lubricating grease is not easily lost, to prevent insufficient lubrication caused by grease depletion, it is recommended to replenish the grease after reaching a usage distance of 100km. At this point, a grease gun can be used to inject the grease into the slider through the grease nozzle attached to the slider. The lubricating grease is suitable for applications where the speed does not exceed 60m/min and no cooling is required.

1-11-2 Grease Frequency

It is recommended that customers use lubricants with a viscosity of approximately 32–150 cSt for linear guide rails. SHAC can install oil fittings at the original oil drain location upon customer request, so customers only need to connect the preset oil fittings to the oil lines. Lubricating oil has higher consumption than lubricating greases, so attention must be paid to ensuring sufficient oil supply during use. Inadequate lubrication may cause abnormal wear and reduce the service life of linear guide rails. It is recommended to maintain an oiling frequency of approximately 3 cm³/hr, with customers adjusting based on their usage conditions. Lubricating oil is suitable for various load and speed conditions, but due to its volatility, it is not recommended for high-temperature applications.

1-11-3 Lubrication Methods

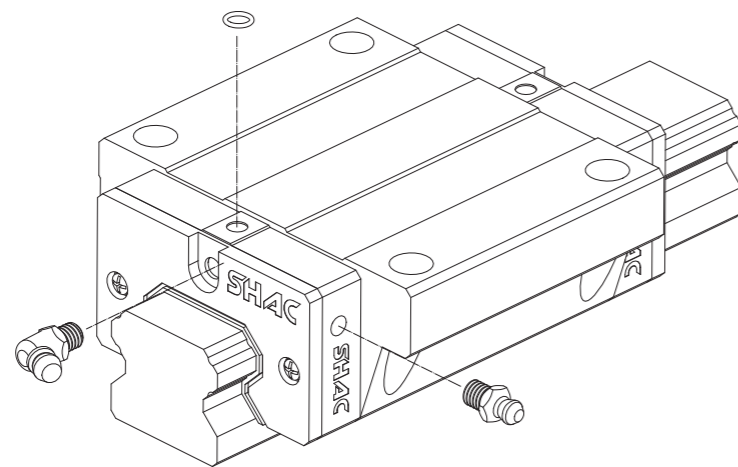

Figure 1-11-1

1-11-4 Lubrication nozzle style (a)

Table 1-11-1 Lubricant Nozzle Style

<p>GA-S</p>	<p>GA-L</p>	<p>GA-XL</p>	<p>GB-S</p>
<p>GB-L</p>	<p>GB-XL</p>	<p>GC-S</p>	<p>GC-L</p>
<p>GC-XL</p>	<p>GD-S</p>	<p>GD-L</p>	<p>GD-XL</p>
<p>GE-S</p>	<p>GE-L</p>	<p>GE-XL</p>	<p>GA-B</p>

Table 1-11-1 Lubricant Nozzle Style (B)

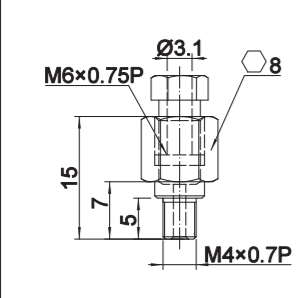
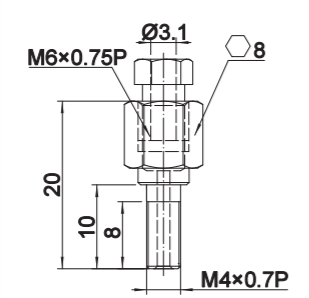
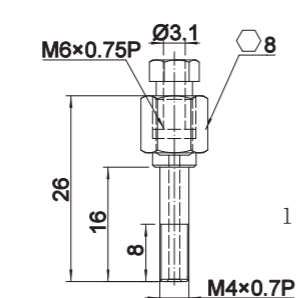
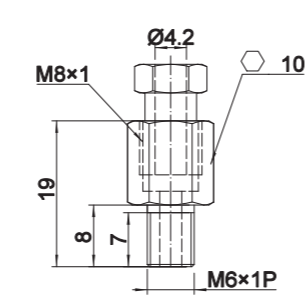
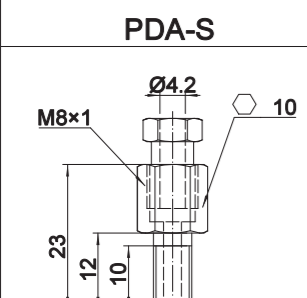
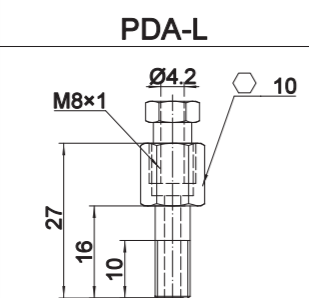
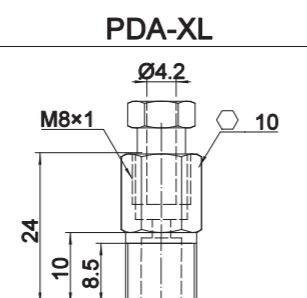
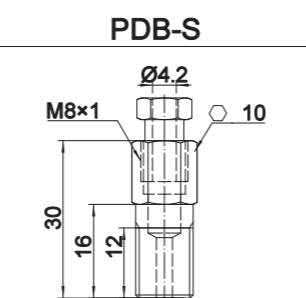
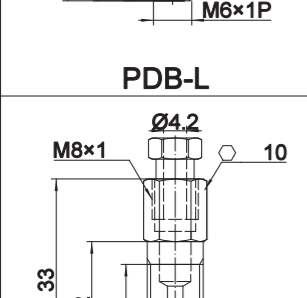
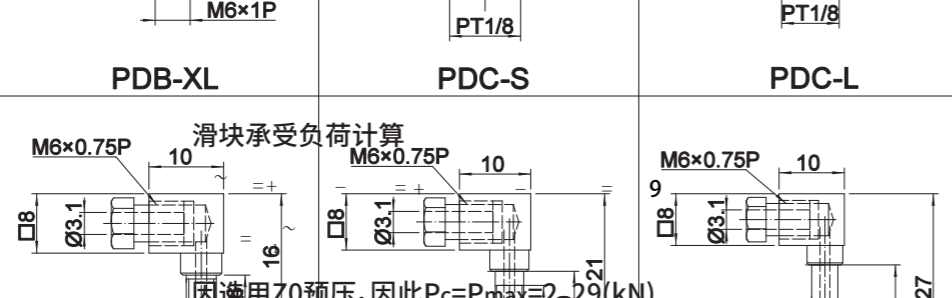
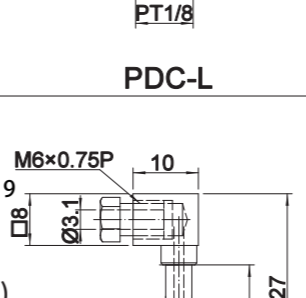
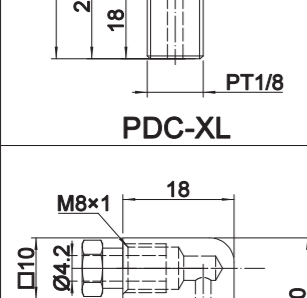
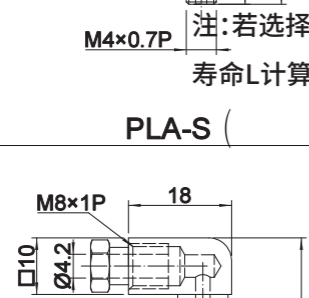
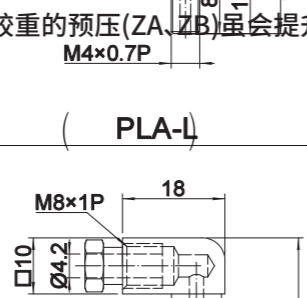
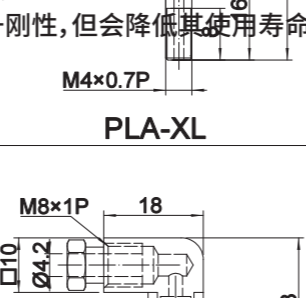
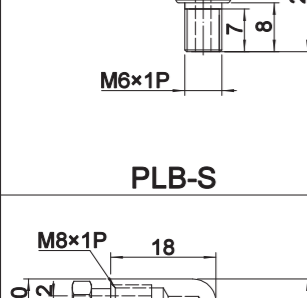
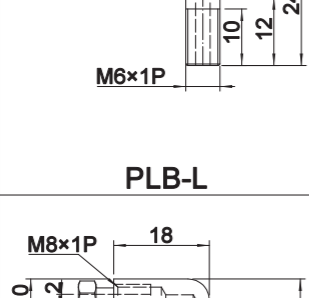
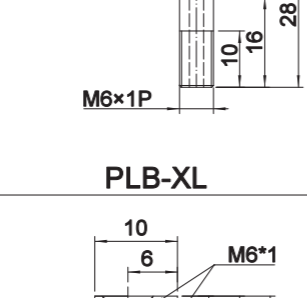
 PDA-S	 PDA-L	 PDA-XL	 PDB-S
 PDB-L	 PDB-XL	 PDC-S	 PDC-L
 PDC-XL			 PLA-XL
 PLB-S	 PLB-L	 PLB-XL	 PLC-S
 PLC-L	 PLC-XL	 TS-A	

1-11-5 Oil Nozzle Specifications

Table 1-11-6

Model	Dust prevention method							
	Standard (Single dustproof sheet)		DD (Double dust-proof plate)		ZZ (Metal scraper + single dustproof sheet)		KK (Metal scraper + dual dustproof sheet)	
	Grease	Oil	Grease	Oil	Grease	Oil	Grease	Oil
15	GA-S	PDA-S	GA-L	PDA-L	GA-L	PDA-L	GA-XL	PDA-XL
		PLA-S		PLA-L		PLA-L		PLA-XL
20-35	GB-S	PDB-S	GB-L	PDB-L	GB-L	PDB-L	GB-XL	PDB-XL
		GC-S		PLB-S		GC-L		PLB-L
45-65	GD-S	PDC-S	GD-L	PDC-L	GD-L	PDC-L	GD-XL	PDC-XL
		GE-S		PLC-S		GE-L		PLC-L

1-11-6 Oil Nozzle Position

We can install oil fittings at the front or rear end of the slider as per customer requirements, with pre-drilled positions also reserved on the side of the end cover to facilitate lubrication from the side. Depending on the lubrication method, oil fittings can be categorized into standard oil fittings and specialized oil pipe fittings.

Table 1-11-3 O-Ring Specifications and Maximum Allowable Depth

Guide rail width	O-Ring Specifications		Punching Maximum Allowable Depth Tmax (mm)
	do (mm)	W (mm)	
15	2.5±0.15	1.5±0.15	3.75
20	4.5±0.15	1.5±0.15	5.7
25	4.5±0.15	1.5±0.15	5.8
30	4.5±0.15	1.5±0.15	6.3
35	4.5±0.15	1.5±0.15	8.8
45	4.5±0.15	1.5±0.15	8.2
55	4.5±0.15	1.5±0.15	11.8
65	4.5±0.15	1.5±0.15	10.8

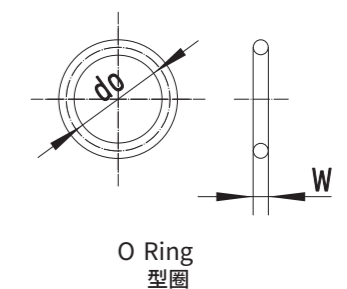

Figure 1-11-2

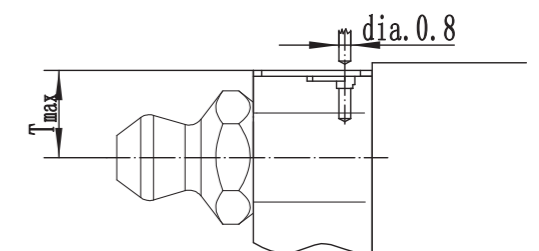

Figure 1-11-3

There are slight differences among the series!

1-11-7 Lubricating oil capacity for single slider

Table 1-11-4 Single Slider Lubricating Oil Capacity

Guide rail width	heavy load (cm ³)	overload (cm ³)	Guide rail width	heavy load (cm ³)	overload (cm ³)
15	1	-	35	10	12
20	2	3	45	17	21
25	5	6	55	26	33
30	7	8	65	50	61

1-11-8 Sliding Method and Frequency

Table 1-11-5 Fuel Supply Rate

Guide rail width	Fuel Supply Rate (cm ³ /hr)	Guide rail width	Fuel Supply Rate (cm ³ /hr)
15	0.2	35	0.3
20	0.2	45	0.4
25	0.3	55	0.5
30	0.3	65	0.6

1-12J Noise Reduction Requirements

- ◎ Based on equipment operational requirements, low vibration noise is required in low noise environments.
- ◎ Precision High-Speed Quiet: spray painting machine, chip-related equipment, noise-related equipment, laser engraving machine, etc.

Table 1-12-1

Item	Product Advantages	corresponding performance
1	Low displacement sound	The efficient steel ball circulation channel, coupled with high-strength synthetic resin components and the chain design that encloses the steel balls, ensures optimal movement paths for the steel balls, resulting in a sound reduction of approximately 5 decibels compared to the GH series
2	Self-lubricating chain belt	Between the steel ball and the chain, there is a certain amount of space to store lubricating grease, ensuring continuous lubrication during the operation of the steel ball, effectively improving smoothness and service life
3	Sync Smooth Excellent	After the self-lubricating chain evenly spaces the steel balls, the chain synchronously activates the steel balls in the non-load area, significantly reducing the variation in frictional resistance and effectively improving the smoothness of travel
4	Auxiliary High-Speed Chain Belt Jia	After the self-lubricating chain evenly spaces the steel balls, it effectively eliminates the reverse rolling friction between adjacent steel balls. Coupled with the action of self-lubricating grease and the circular linear contact design between the steel balls and the chain, it significantly reduces frictional resistance, enabling the low-noise linear track to operate at high speeds
5	Pre-load more suitable	The fourth-grade standard preload is available for selection, which can further enhance accuracy and rigidity
6	Dustproof Accessories Complete	Standard dust-proof configuration and optional DD, KK, ZZ dust-proof kits
7	common rail structure	Low-noise QE and QH adopt a common-track design, with a constant combination height

1-12-1 QH Series - Silent Heavy-Duty Ball Linear Guide Rail

SHAC's QH series silent linear guideway is a high-performance linear guideway actively developed to enhance competitive advantage, based on a four-row single-arc tooth profile design. The QH series linear guideway with SynchMotion™ technology is equipped with a patented synchronous connector with oil storage function, which can effectively reduce noise during operation and improve operational smoothness, lifespan, and lubrication efficiency. The QH series linear guideway with SynchMotion™ technology has a wider range of industrial applications and is more suitable for high-tech industries that require high speed, quiet operation, and low dust generation

Ontology structure

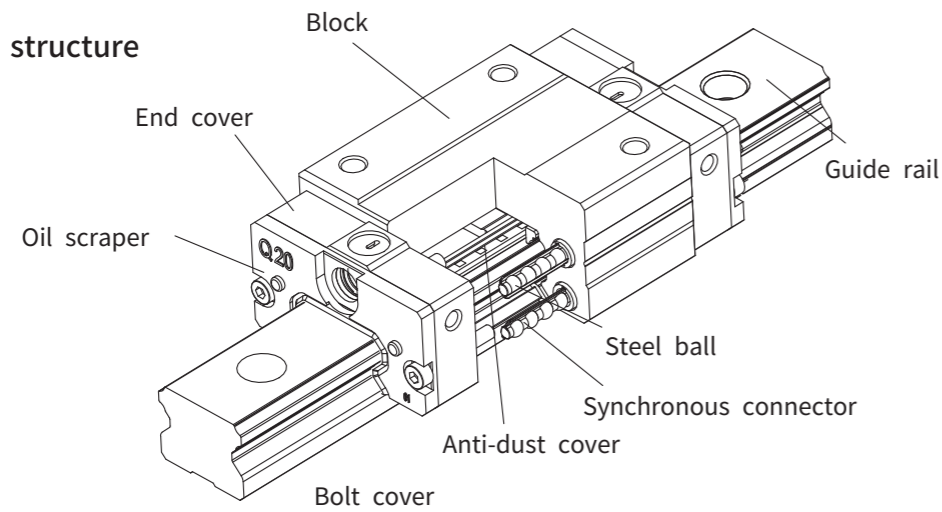

Figure 1-12-1

1-12-2 Low noise design

Using a synchronous connector can ensure that steel balls are evenly and equally spaced, preventing mutual collisions between them and effectively reducing the intensity of high-frequency sharp sounds (see the lower right image). Compared to the previous series, the overall sound intensity can be effectively reduced by about 5 decibels (see the lower left image)

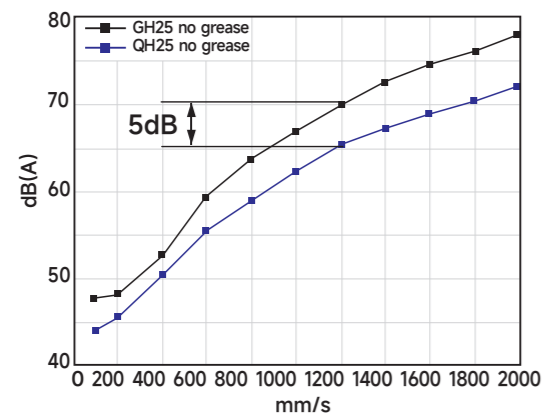

Figure 1-12-2

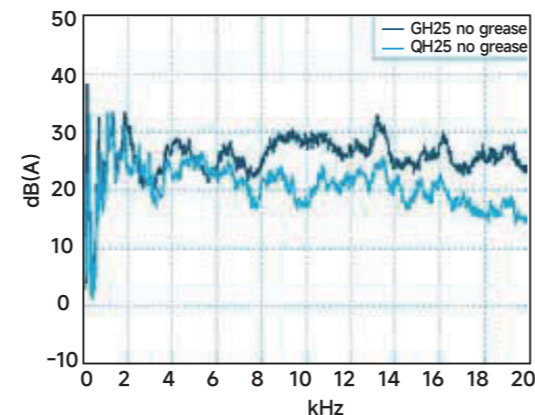

Figure 1-12-3

1-12-3 Self-lubricating design, no need to add oil

The patented synchronous connector features a space for oil storage in the middle spacer, which can provide lubrication for the steel balls during operation. When passing through the direction-turning part, it can evenly replenish the lubricating oil in the oil storage space, continuing to lubricate the steel balls evenly. Therefore, the frequency of replenishing lubricating oil can be effectively reduced. The test data in Table 2-3-1 shows that by adding high-performance lithium soap-based grease before leaving the factory, it can sustain a service life of over 4,000 kilometers under 0.2 times the rated dynamic load without experiencing fatigue damage. Therefore, by adding high-performance lubricating grease at the factory, it can ensure its service life without requiring maintenance under normal light load conditions.

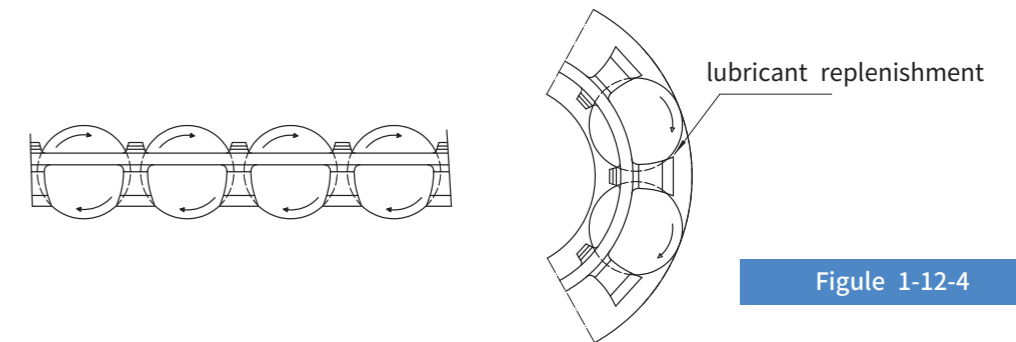

Figure 1-12-4

Table 2-3-1 Self-lubrication Test Data

specimen	QHH25CAZAH	load testing
speed	24m/min	<p>Load=5kN After 4,000km</p>
lubrican	Lithium soap-based grease (initial addition)	
Load	5kN	
walking distance	4,000 kilometer	

1-12-4 Improve the smoothness of movement

When traditional linear guide rails without synchronizers start operating, the steel balls on the load side will move first, then push the directional rotary part and the steel balls on the unloaded side, causing a chain of back-and-forth collisions, which results in severe fluctuations in frictional resistance. However, the QH series linear guide rails using SynchMotion™ technology have synchronizers that connect all the steel balls in the same cycle. Therefore, when the slider starts moving, all the steel balls start almost simultaneously, and there is no back-and-forth collision between the steel balls. With a certain degree of motion inertia maintained, the fluctuation range of frictional resistance can be effectively reduced

Frictional resistance test diagram

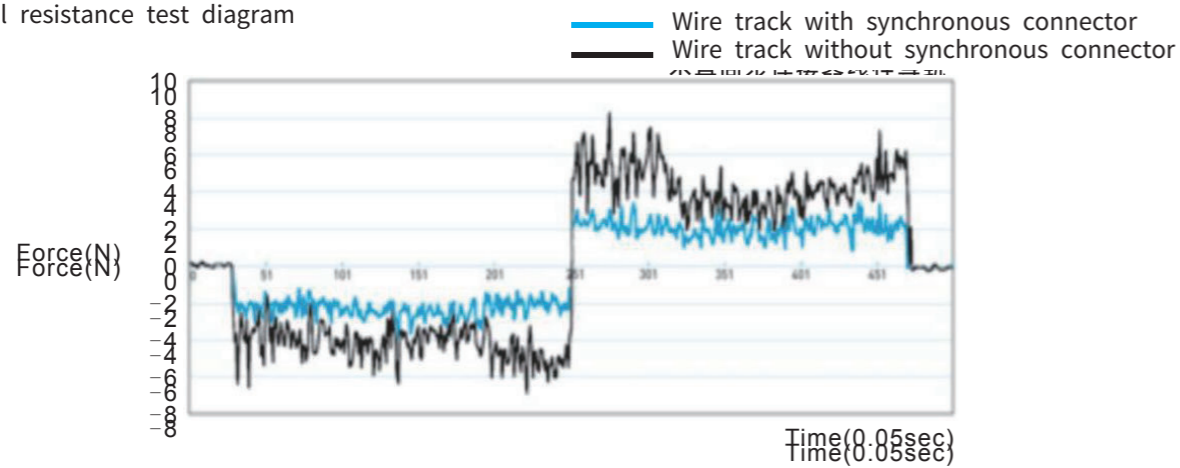

Figure 1-12-4

1-12-5 High-speed Design

The spacer design of the SynchMotion™ synchronizer eliminates the mutual friction between steel balls, and the patented design of SHAC ensures that the steel balls make circular linear contact with the synchronizer, thereby effectively reducing the friction coefficient. This makes the SynchMotion™ silent linear guideway exhibit excellent high-speed performance

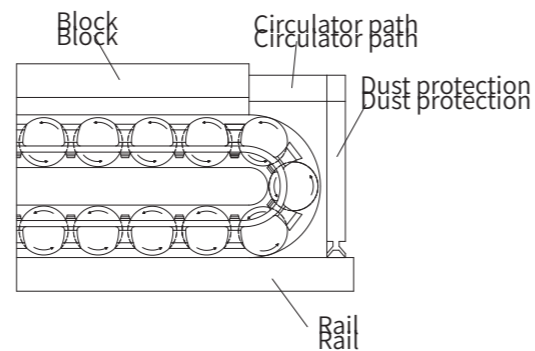

Figure 1-12-5

Table 1-12-3 High-Speed Displacement Test Data

specimen	QHW25CCZAH	high-speed testing
Speed	130m/min	
lubricant	Lithium soap based grease (initial addition)	
walking distance	9000 kilometer	

1-13 K. Surface treatment

- ◎ Improve wear resistance
- ◎ Enhance corrosion resistance

The main purpose of surface treatment for linear guides is to improve material surface properties, enhance wear resistance, corrosion resistance, and service life.

1-13-1 Improve wear resistance

Surface treatment (such as chrome plating, ion nitriding, etc.) can significantly enhance the hardness of the screw surface (up to 55-65 Rockwell hardness), reduce the friction coefficient, and minimize wear. For example, chrome plating can reduce surface roughness, make the contact between the ball and the guide rail smoother, and extend the service life.

1-13-2 Enhance corrosion resistance

The chromium layer has high stability in humid environments, acid-base solutions, and organic acids, and can effectively prevent oxidation and chemical corrosion, especially suitable for precision equipment that is sensitive to the environment.

For devices used in various environments, SHAC linear guides offer a variety of surface treatments, including blackening, chrome plating, phosphate plating, nickel plating, and cold plating services.

The unprocessed surfaces of Dinghan heavy-duty roller slider (GH series) are all blackened, while the unprocessed surfaces of roller slider (GR series) are sandblasted.

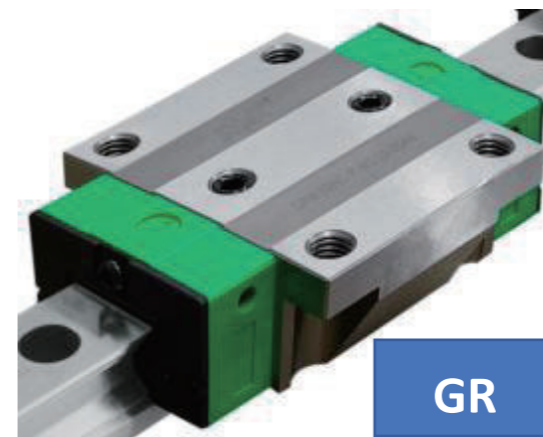

GR

Figure 1-13-1



GH

Figure 1-13-2

1-14 L. Dustproof design

◎ The dust-proof design of linear guides is mainly achieved through a combination of multi-stage sealing structures and external protection

Contact type sealing gasket: Made of high wear-resistant synthetic rubber, the oil scraper, bottom dust cover, and sealing end cap directly seal the gap between the slider and the guide rail to prevent dust from entering.

1-14-1 External protective devices

Flexible steel strip cover: achieves dynamic sealing through magnetic sealing strips, suitable for clean environments.

Organ cover: The fully enclosed structure has the best dust-proof performance and supports vertical installation, but long travel requires reserved compression space

1-14-2 Sliding block dustproof accessories

In general, standard dust prevention is used in operating environments without special requirements. If the following dust prevention accessories are needed, please indicate the code after the product model.

- Improve wear resistance
- Enhance corrosion resistance

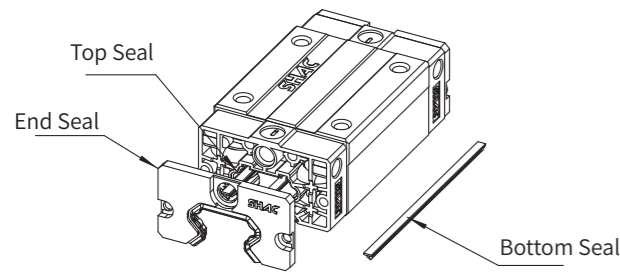

No marked as dustproof standard accessories
(End seal+Bottom Seal)

Figure 1-14-1

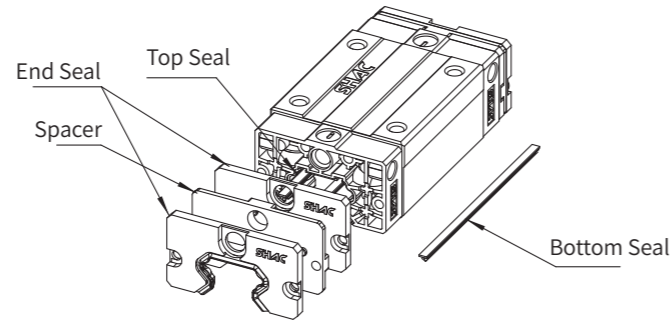

DD(Double End Seal+Bottom Seal)

Figure 1-14-2

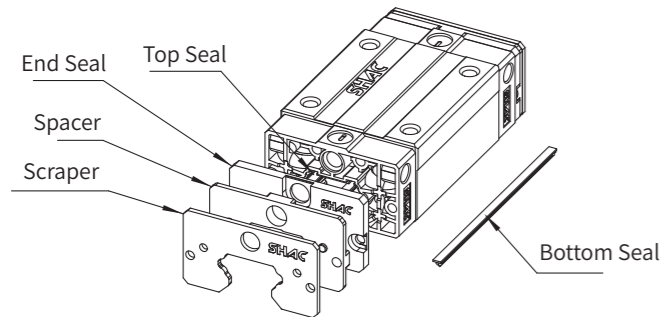

ZZ(End seal+Bottom Seal+Scraper)

Figure 1-14-3

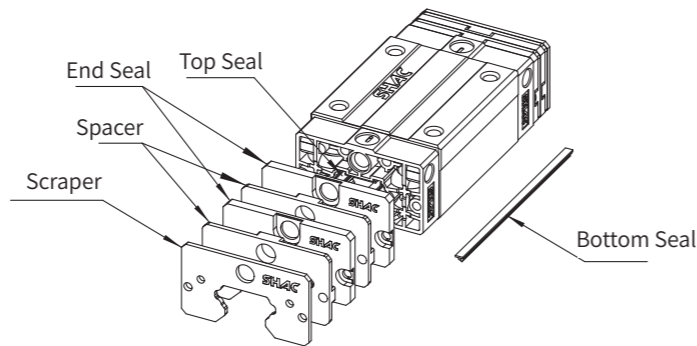

KK(Double End seal+Bottom Seal+Scraper)

Figure 1-14-4

Dust prevention accessory instructions

When the slider moves back and forth, hard debris such as iron filings can enter the slider and damage the surface of the groove, reducing the accuracy and lifespan of the linear guide. Foreign objects such as dust and sawdust can accumulate in the ball path, causing problems such as ball bursting. In order to ensure its normal use, appropriate dust prevention measures must be taken.

Dust sheet and bottom dust strip

Dust sheets and dust strips can effectively prevent debris or dust from entering the interior of the slider.

Double layer dust-proof sheet

Double the dust prevention effect, even in more harsh processing environments, it can still have excellent dust prevention effect.

Metal scraper

Thanks to the high temperature resistance and hardness of metals, they can effectively isolate high-temperature iron filings and large foreign particles.

Spacer

The stacking of dust-proof layers affects the fit between the dust-proof sheets and the guide rail, thereby increasing friction. Adding spacers between the dust-proof sheets can ensure preloading and more effectively prevent dust.

Apply dust strips

It can effectively prevent small dust from entering the ball lane.

Guide rail cover

Dust and foreign objects can enter the interior of the slider through the installation holes, affecting accuracy and lifespan. After using a dedicated cover to block the installation hole, make the installation hole surface align with the flat surface of the guide rail. It can effectively prevent foreign objects from entering the interior of the slider.

1-14-3 High dustproof accessory code

We have developed reinforced high dust-proof accessories for customers to choose from in harsh usage environments, which have excellent dust-proof capabilities and can effectively prevent foreign objects from entering the interior of the slider. If you need the following high dust-proof accessories, please indicate the code after the product model.

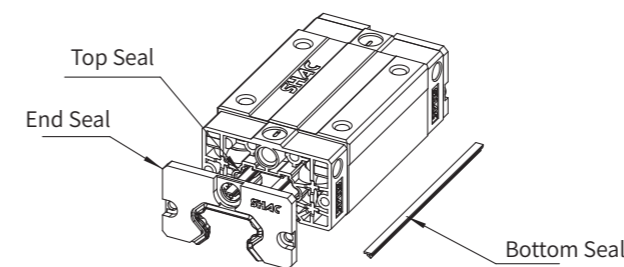

SH = End seal(High Dust Proof)+Bottom Seal+Top Seal

Figure 1-14-5

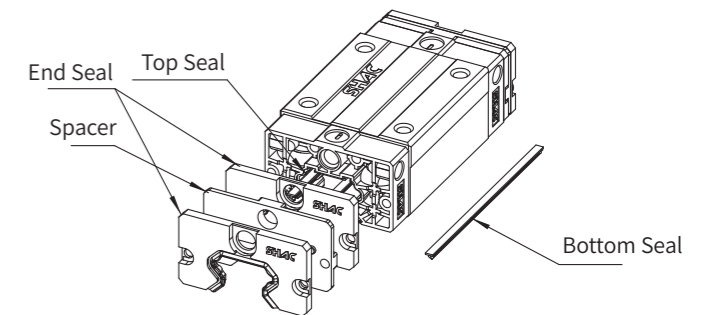

DH = Double End seal(High Dust Proof)+Bottom Seal(High Dust Proof)+Top Seal

Figure 1-14-6

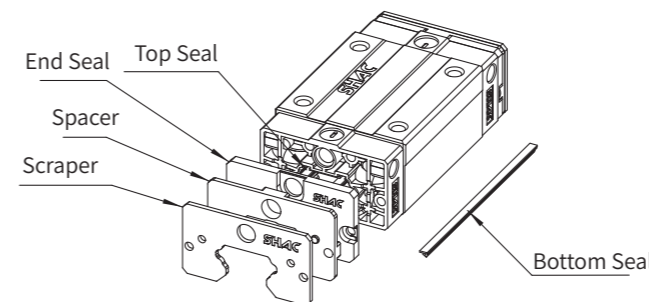

ZH = (End Seal(High Dust Proof)+Bottom Seal(High Dust Proof)+Top Seal+Scraper)

Figure 1-14-7

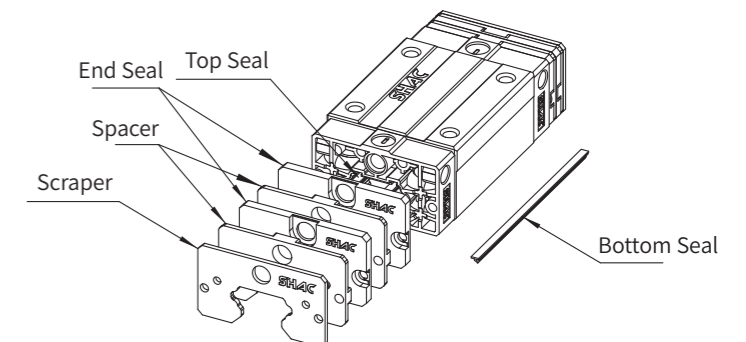

KH = Double End seal(High Dust Proof)+Bottom Seal(High Dust Proof)+Scraper

Figure 1-14-8

1-14-4 Friction Force

The resistance values in the following table are the maximum resistance of two dust sheets.

Table 2-3-20 GH series dust sheet resistance values

Rail width	Standard dust sheet resistance(kgf)	Rail width	Standard dust sheet resistance(kgf)	Resistance of heavy preloaded dust sheet (kgf)
15	1.5 (0.15)	35	4.5 (0.46)	-
20	2.55 (0.26)	45	6 (0.61)	8 (0.81)
25	3.00 (0.3)	55	6.9 (0.7)	10 (1.00)
30	3.9 (0.4)	65	8.7 (0.89)	12 (1.2)

Note: 1kgf=9.81N

1-15 M. Rail butt-joint

◎ Position butt-joint ◎ Minimum gap ◎ Connection number

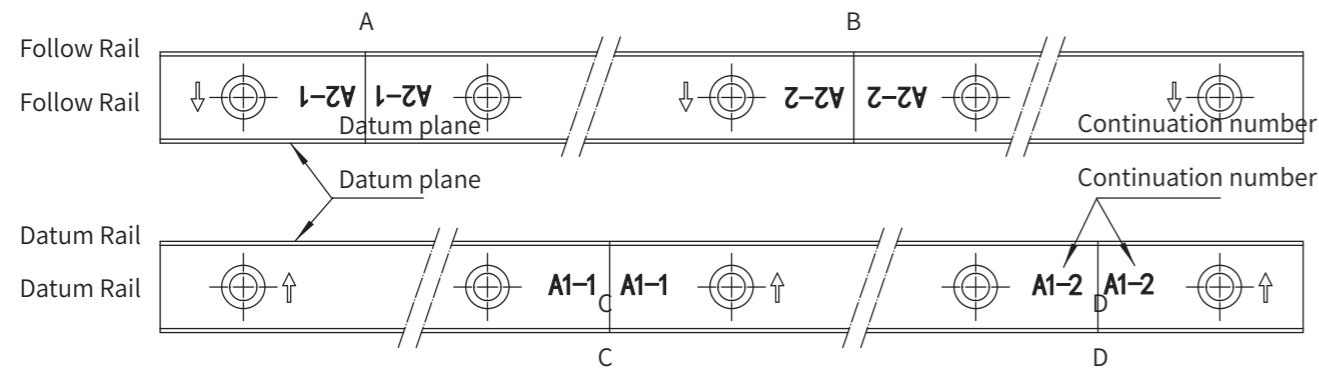

Figure 1-15-1

Due to manufacturing process, material characteristics, transportation and installation limitations, the length of a single slide rail cannot be made too long. To overcome these limitations, docking specifications (i.e. splicing two or more slides together) are commonly used to achieve the required length.

When designing the docking of linear guides, the method of aligning the two guide rail docking positions is adopted to avoid overlapping, which means that the possible vibration when the rotor crosses the docking line only occurs on one side of the guide rail. (The four joints A, B, C, and D in Figure 1-15 do not overlap.)

When designing the docking of linear guides, the minimum clearance method will be used to minimize



Figure 1-15-2

the possible jumping of the rotor when passing through the docking position of the two guides. During the production docking of linear guides, the two guides will be numbered consecutively, and the adjacent ends of the two guides will be numbered with the same number. (Figure 1-15 1A1B, 2A2B)

1-16 N. Guide rail configuration

◎ Utilizing the characteristics of linear guides to meet the needs of structures and loads

Linear guide rails can withstand loads from all directions, so linear guide rail groups can be configured according to the machine structure and the direction of the working load.

The configuration scheme needs to be designed comprehensively based on the equipment operation requirements, load conditions, and accuracy requirements. The following are common configuration schemes and precautions:

1-16-1 Configuration of single guide rail bearing surface

Suitable for scenarios with low precision requirements, ensuring precise positioning of the guide rail through positioning blocks or pins.

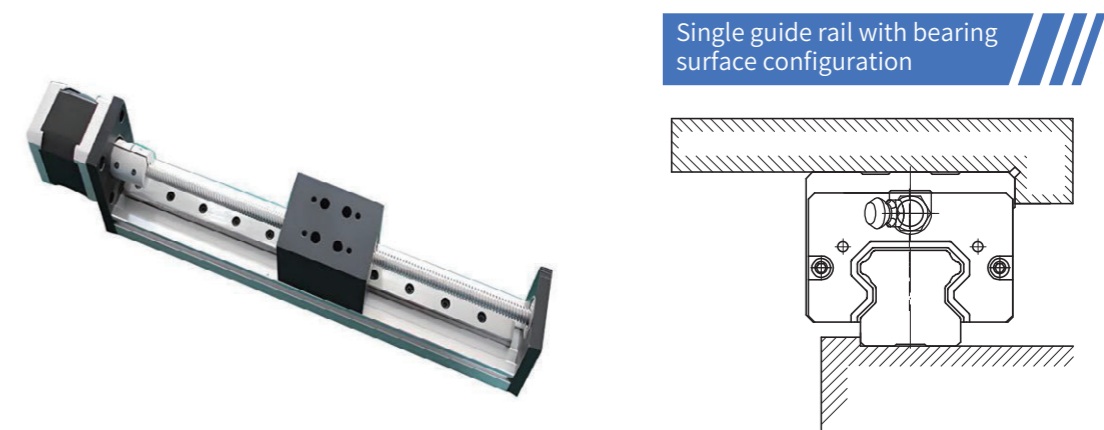

Figure 1-16-1

1-16-2 Two rail sliders movement configuration

Rail fixing method: The position of the rail is limited by a fixed bracket, suitable for environments with low vibration and impact.

Sliding block fixing method: The sliding block is directly fixed on the workbench, suitable for high-precision demand scenarios.

Two guide rail slider movement configuration

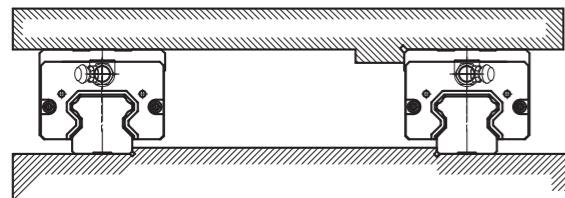

Figure 1-16-2

Two guide rail slider movement configuration

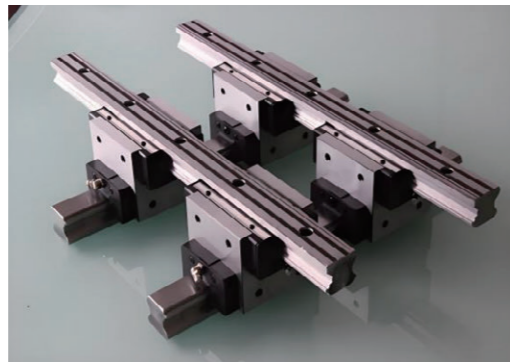
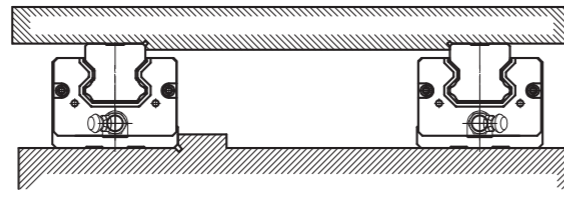
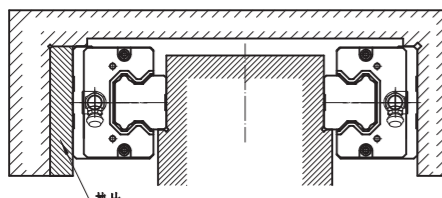

Figure 1-16-3

1-16-3 configuration of two opposite/back facing guide rails

It is commonly used in situations that require multi-directional support, and can be combined to enhance system stability.

Two opposing guide rail configurations



Two guide rail configurations with opposite phases

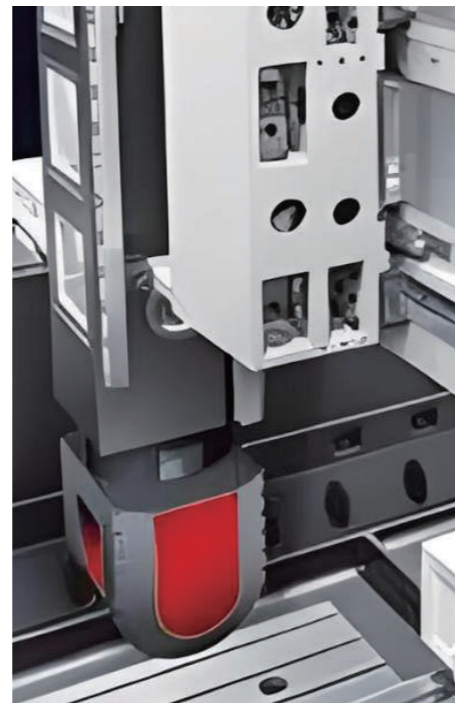
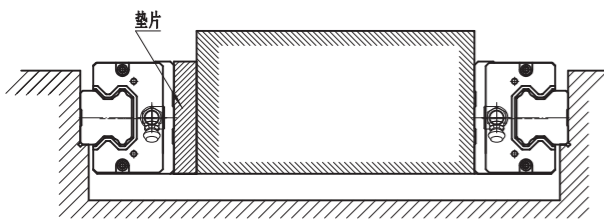

Figure 1-16-4

1-16-4 Comprehensive fixed configuration

High precision motion control is achieved through the combination of multiple guide rails, which is commonly used in precision equipment.

Fully fixed configuration

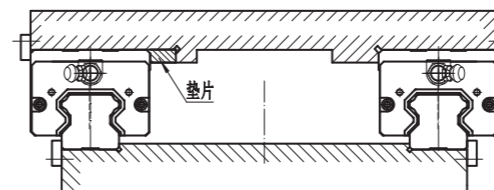

Figure 1-16-5

GHW type slider fixing screws are configured in different directions

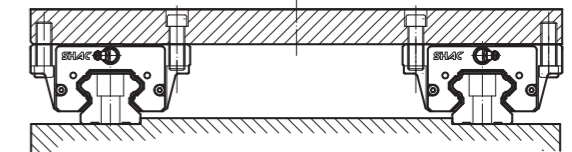

Figure 1-16-6

1-17 O. Installation of guide rails

The installation accuracy determines the quality of the equipment

According to the degree of vibration and impact force experienced by the machine during use, as well as the requirements Choose different installation methods based on the required precision and rigidity.

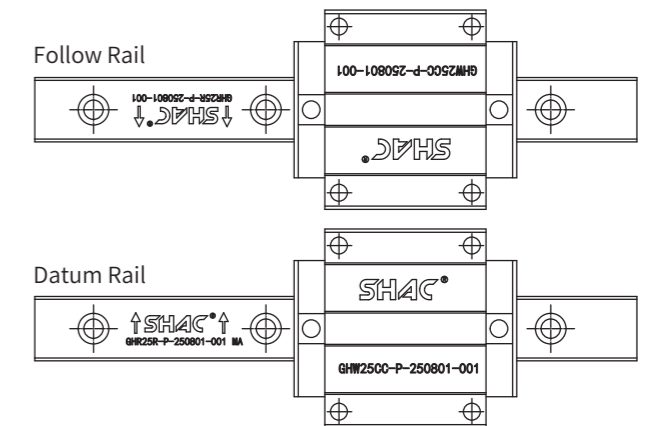

Figure 1-16-7

1-17-1 Representation of straight-line guide benchmark measurement

The reference surface of the guide rail is marked next to the model logo on the front of the guide rail, with an arrow

The side referred to is the reference plane of the guide rail.

Linear guides used in pairs on the same plane include reference rails and

The difference between moving rails is that the reference rail will be engraved with the letter MA after the model identification

As shown in the following figure. There will also be precision grinding on the slider according to the specified accuracy

Please ensure that the reference surface is tightly attached to the workbench during installation The bearing surface is fixed.



1-17-2 Installation when there is vibration and impact during machine operation and high rigidity and precision are required

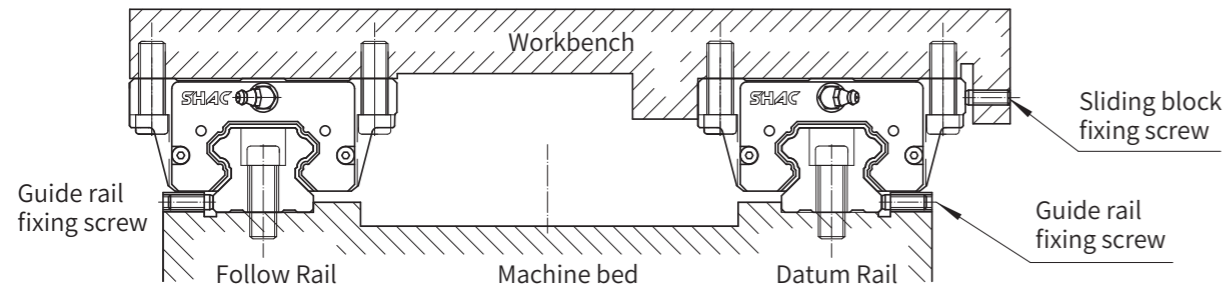

Figure 1-17-1

1-17-3 Rail fixing method

Fix with pressure plate

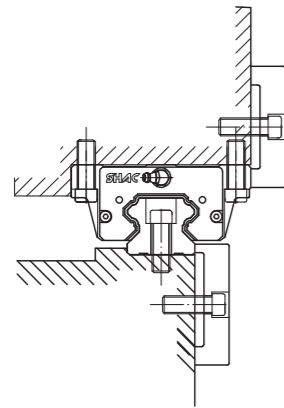

Figure 1-17-2

Secure with bolts

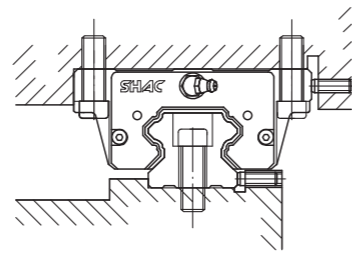

Figure 1-17-3

Use push pull fixation

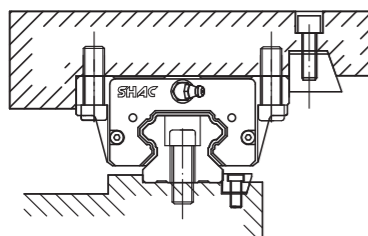

Figure 1-17-4

Using rollers fixed

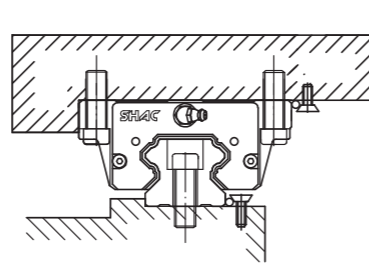

Figure 1-17-5

1-17-4 Guide rail installation

1. Before installation, it is necessary to clean the burrs and dirt on the installation surface of the machine.

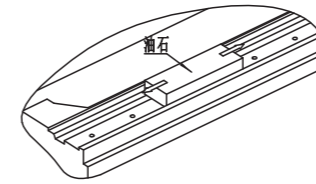

Figure 1-17-6

2. Place the linear guide rail flat on the machine, ensuring that the reference surface of the guide rail is tightly attached Machine support surface

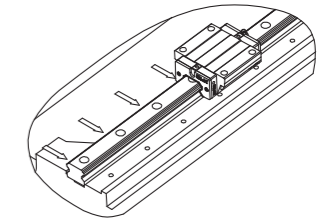

Figure 1-17-7

3. Tighten the fixing screws, but do not tighten them.

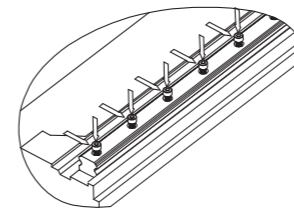

Figure 1-17-8

4. Tighten the positioning screws on the side of the guide rail in sequence to ensure that the guide rail is tightly attached to the bearing surface of the machine.

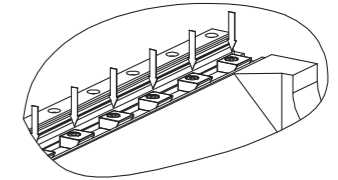

Figure 1-17-9

5. Use a torque wrench to sequentially tighten the fixing screws with the specified torque value.

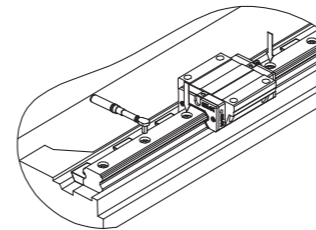

Figure 1-17-10

6. Install another guide rail using the same method.

1-17-5 slider installation

1. Install the workbench onto the slider and secure it with fixing screws, but do not tighten them.

2. Use side positioning screws to lock the slider reference surface with the worktable bearing surface.

3. Tighten the fixing screws in order of the diagonal of the slider from 1 to 4.

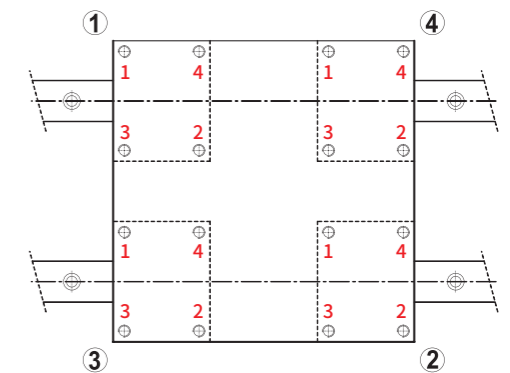

Figure 1-17-11

1-17-6 Installation of guide rails without side positioning screws

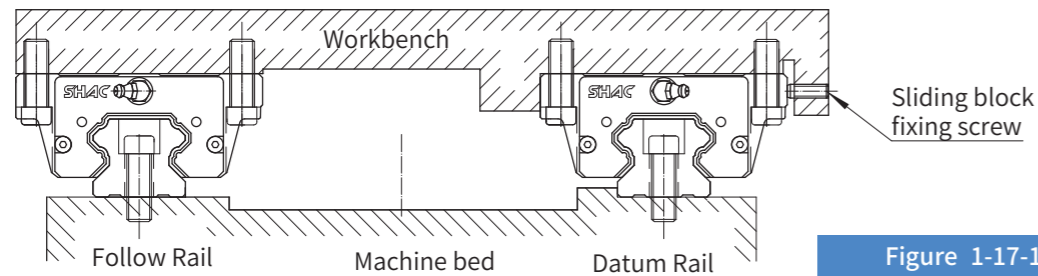

Figure 1-17-12

(1) Installation of reference rail

Tighten the guide rail onto the fixing screw, but do not tighten it. Use pliers to secure the guide rail. The rail reference surface is in close contact with the machine bearing surface, and then a torque wrench is used. Tighten the fixing screws in sequence with the specified torque value.

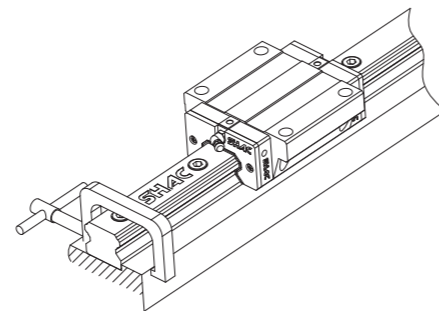

Figure 1-17-13

(2) Installation of the driven rail

Place a straight-line block gauge or marble ruler between two guide rails and use a thousand. Adjust the square gauge to be parallel to the reference plane on the guide rail side, and then use the square. Adjust the guide rail on the driven side based on the standard and lock the fixing screws in sequence. Silk.

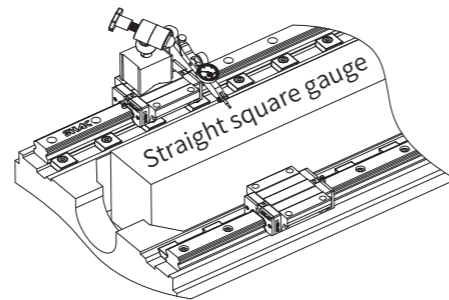

Figure 1-17-14

(3) Mobile Workbench Method

Fix and lock the two sliders of the reference rail onto the workbench, from Only one slider is installed on the moving rail, which is also fixed to the workbench but not locked.

Fix the dial gauge on the workbench and place the measuring point on the slider of the driven rail. On the reference plane, the workbench starts moving from one end of the guide rail and searches on one side. Tighten the fixing screws with the specified torque on one side of the parallelism.

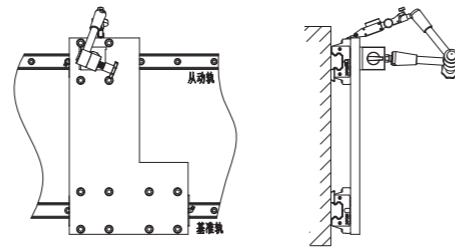

Figure 1-17-15

(4) Following the benchmark orbit method

Fix and lock the two sliders of the reference rail onto the workbench, and follow them. Only one slider is installed on the track, which is also securely locked to the workbench. Workbench from one end of the guide rail begins to move, feeling the resistance of the platform on one side and regulating it on the other. Tighten the fixing screw with torque.

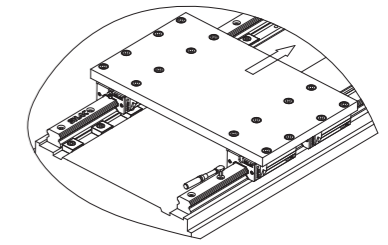

Figure 1-17-16

(5) Special tool installation method

Special measuring tools will be used, with the side reference plane of the reference rail as the base. Accurately adjust the position of the driven rail starting from one end of the guide rail and following the specifications. Tighten the fixing screw with a fixed torque.

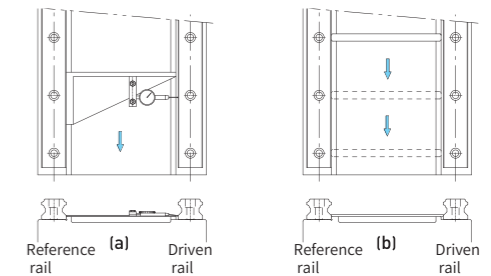

Figure 1-17-17

1-17-7 The machine does not have a supporting surface for installation

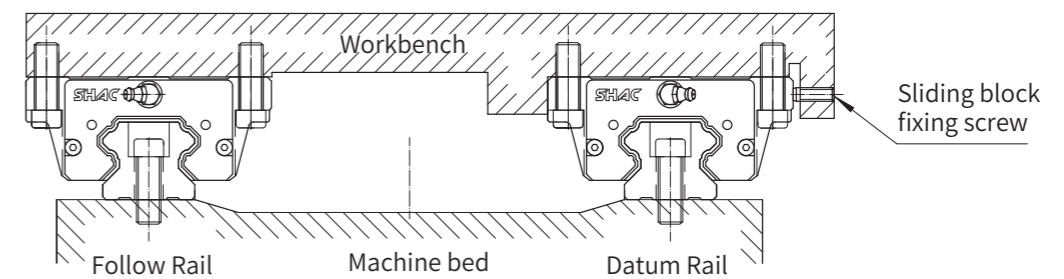

Figure 1-17-18

(1) Installation of reference rail

Using the false reference surface method. Tighten and fix the two sliders onto the measuring platform, and guide them with the machine. The plane near the installation position of the rail is the reference plane, which is opened from one end of the guide rail. Start moving, use a dial gauge to adjust the straightness of the guide rail on one side and gauge on the other side. Tighten the fixing screw with a fixed torque.

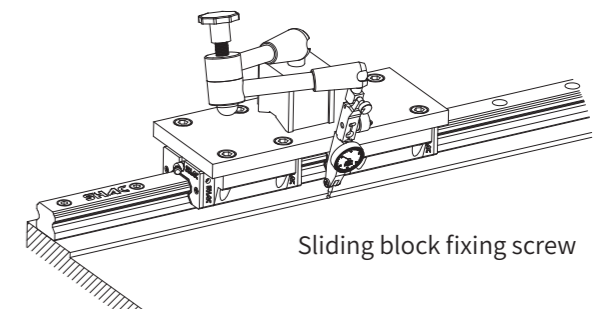

Figure 1-17-19

(2) Installation of the driven rail

©Straight-line square method

Based on the square gauge, start moving from one end of the guide rail and use a dial gauge to adjust the straightness of the guide rail while locking the fixing screw with the specified torque.

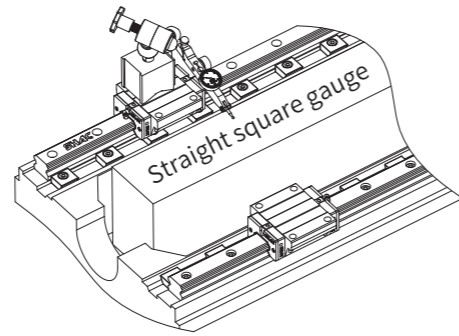

Figure 1-17-20

(3) Installation of the driven rail

The installation method of the driven rail is the same as that in the previous section "Installation of the guide rail without side positioning screws".

2. Product Series





SHAC has prepared various types of linear guide products for customers to meet their requirements for product performance in all aspects. In addition to the conventional GH series high group, low group, flange type, square type and other types, we have also researched and developed the GE series with a combination ratio lower than GH low group, as well as the QH/QE series with better noise control and smoother operation, and the GR/QR series with stronger rigidity and larger load.

Table 2-1-1

series	Combination height	Load type	Square	Flange	
			Upper locking type	Upper and lower locking type	Locking type below
GH	High group	Heavy load	GHH-CA		
		Overweight load	GHH-HA		
	Low group	Heavy load	GHL-CA	GHW-CC	GHW-CB
		Overweight load	GHL-HA	GHW-HC	GHW-HB
GH-S	Steel strip high group	Heavy load	GHH-CA-S		
		Overweight load	GHH-HA-S		
GE	Low group	Medium load	GEH-SA	GEW-CS	GEW-SB
		Heavy load	GEH-CA	GEW-CC	GEW-CB
WE	High group	Heavy load	WEH-CA	WEW-CC	
QH	High group	Heavy load	QHH-CA		
		Overweight load	QHH-HA		
	Low group	Heavy load		QHW-CC	QHW-CB
		Overweight load		QHW-HC	QHW-HB
QE	Low group	Medium load	QEH-SA		QEW-SB
		Heavy load	QEH-CA		QEW-CB
GR	High group	Heavy load	GRH-CA		
		Overweight load	GRH-HA		
	Low group	Heavy load		GRW-CC	GRW-CB
		Overweight load		GRW-HC	GRW-HB
GR-S	steel strip high group	Heavy load	GRH-CA-S		
		Overweight load	GRH-HA-S		
GMN		standard	GMN-C		
		length	GMN-H		
GMW		standard	GMW-C		
		length	GMW-H		

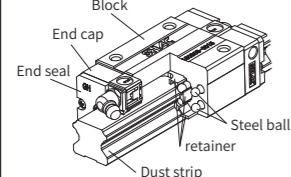
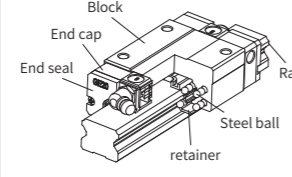
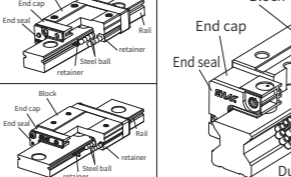
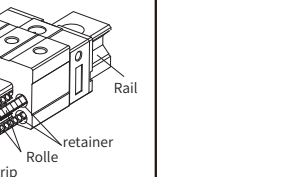
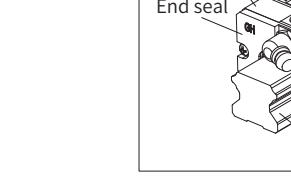
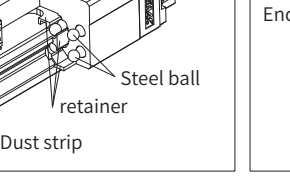
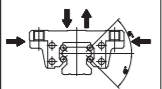
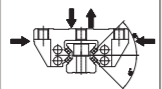
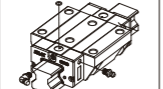
2-1 Product Structure and Advantages

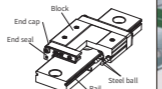
Table 2-1-2

Block Type	GH Series	GE Series	QE Series	QH Series	GM Series	GR Series
Product Structure						
Product Advantages	High assembly, self regulating, easily interchangeable  C to SUP grade, high-precision reproduction of micrometer level motion, less prone to crawling, also fully equipped with functional configurations; Dustproof accessories, various oil nozzles, and rail mounting from bottom. DF45 degree X-shaped force structure, Equipped with automatic centering capability, easy to install and use	Low assembly, self regulating, easily interchangeable  A) Eight self selected lubrication positions, B) Equipped with SL self-lubricating components, C) Smooth movement, D) Low noise displacement	Chain belt low assembly 	Chain belt High assembly 	Roller overload  a. Two Gothic style raceways b. 45 degree contact angle c. Small and lightweight d. Low friction resistance e. Same load in all directions f. Smooth and low-noise	Chain caged roller  C to SUP level, high-precision reproduction of micrometer level motion, Wire contact replaces point contact in terms of force, with super strong loads in all directions, including up, down, left, and right, ultra-high rigidity, and long service life DB45 degree O-shaped force structure, precisely matched with zero clearance, smooth and quiet movement displacement, meets the requirements of high quietness, high rigidity, high load, and high precision for equipment use

2-1-1 Names of each part of the linear slide rail

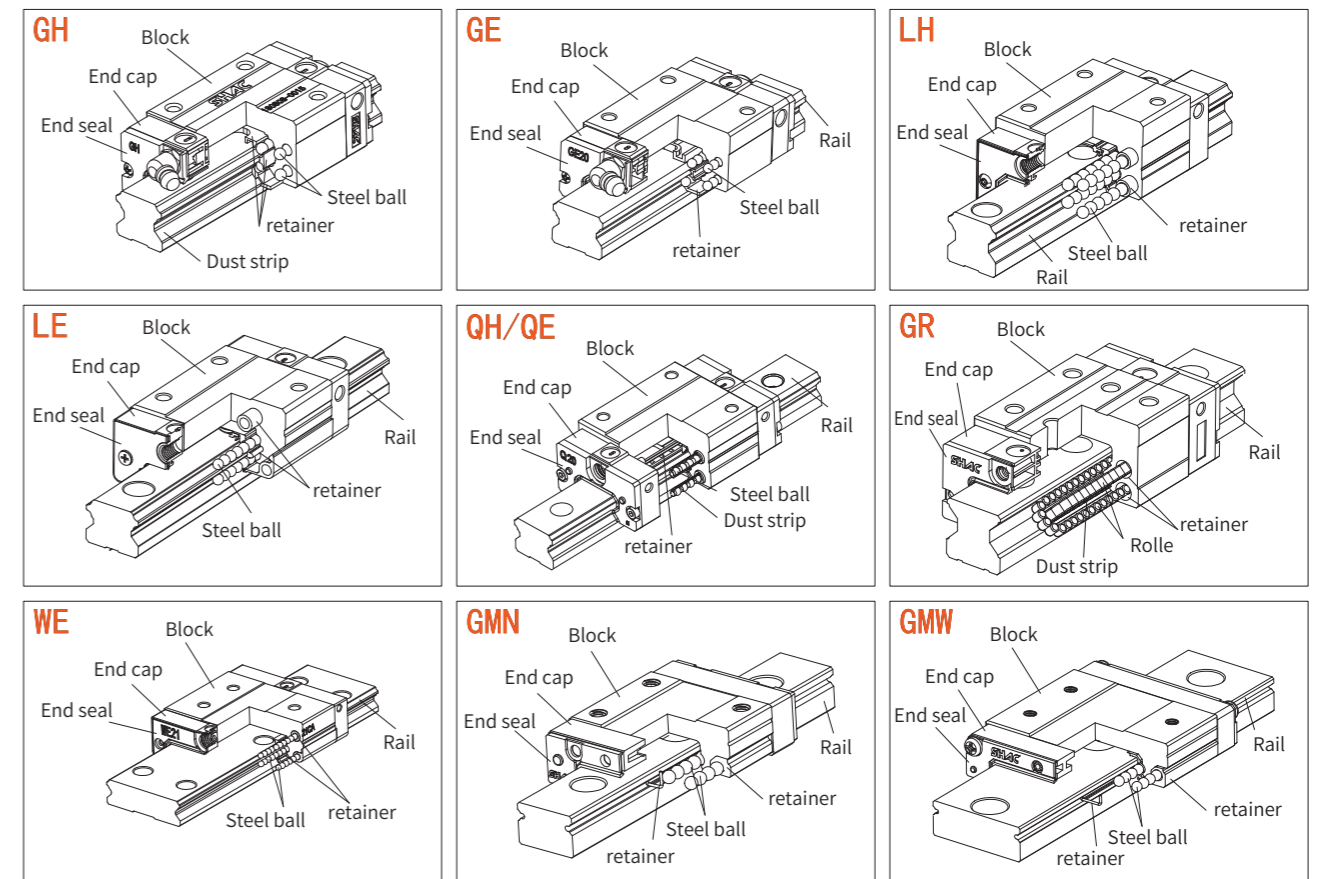

Figure 2-1-1

2-2 GH Series - Heavy Duty Ball Linear Guide

GH series linear guide rail adopts four-row arc groove 45° contact angle design, and optimized structure design can achieve load energy in four directions

The same force can be used regardless of various installation methods of X, Y and Z axes. It has high load capacity and dynamic regulation functions,

The product rigidity can be further improved by improving the assembly preload, which is especially suitable for the demands of high-precision and high-load products.

Product characteristics

High rigidity

The four-row arc groove and high rigid section design can not only provide excellent load capacity in four directions, but also improve the product rigidity step by step by improving the assembly preload.

Dynamic adjustment

Due to DF combination of circular groove (45° - 45°), it has dynamic adjustment capacity. Even if there

is a fixed deviation on the installation surface, it can reach a balanced state and maintain stable and high-precision linear motion, thus greatly improving the service life and accuracy of guide rail pair.

Interchangeability

Under the advanced manufacturing technology and strict quality control, the product size can be maintained within the stable tolerance, so the guide slides of the same model can be matched with each other, and the same smoothness and accuracy can be maintained.

Product Structure

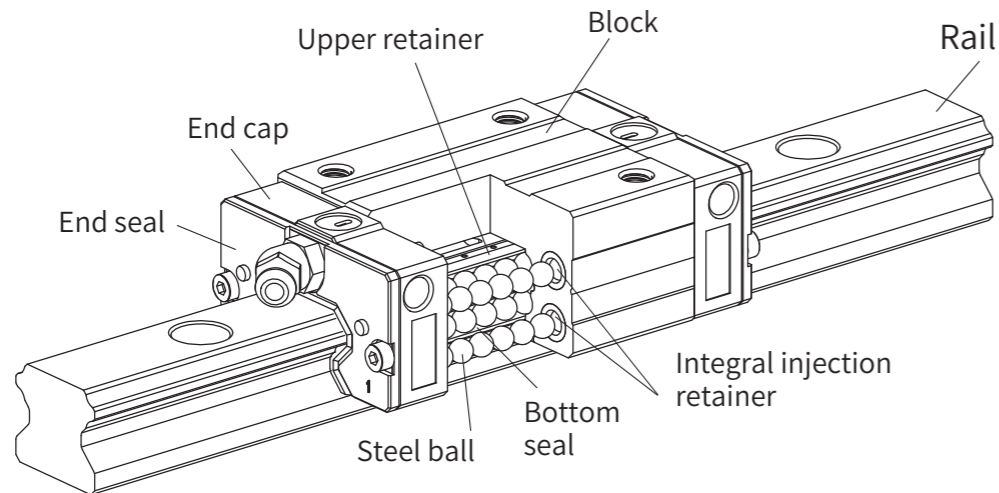

- Rolling cycle system: slider guide rail, end cover, steel ball and steel ball retainer
- Lubrication system: nozzle, oil pipe joint, end cover, steel ball, steel ball retainer
- Dust prevention system: dust strip, bottom dust seal dust strip, guide rail cap, metal scraper

Figure 2-1-2 LHH20CA

2-2-1 GH Series - Heavy Duty Ball Linear Guide

Product model of non-interchangeable linear guide rail

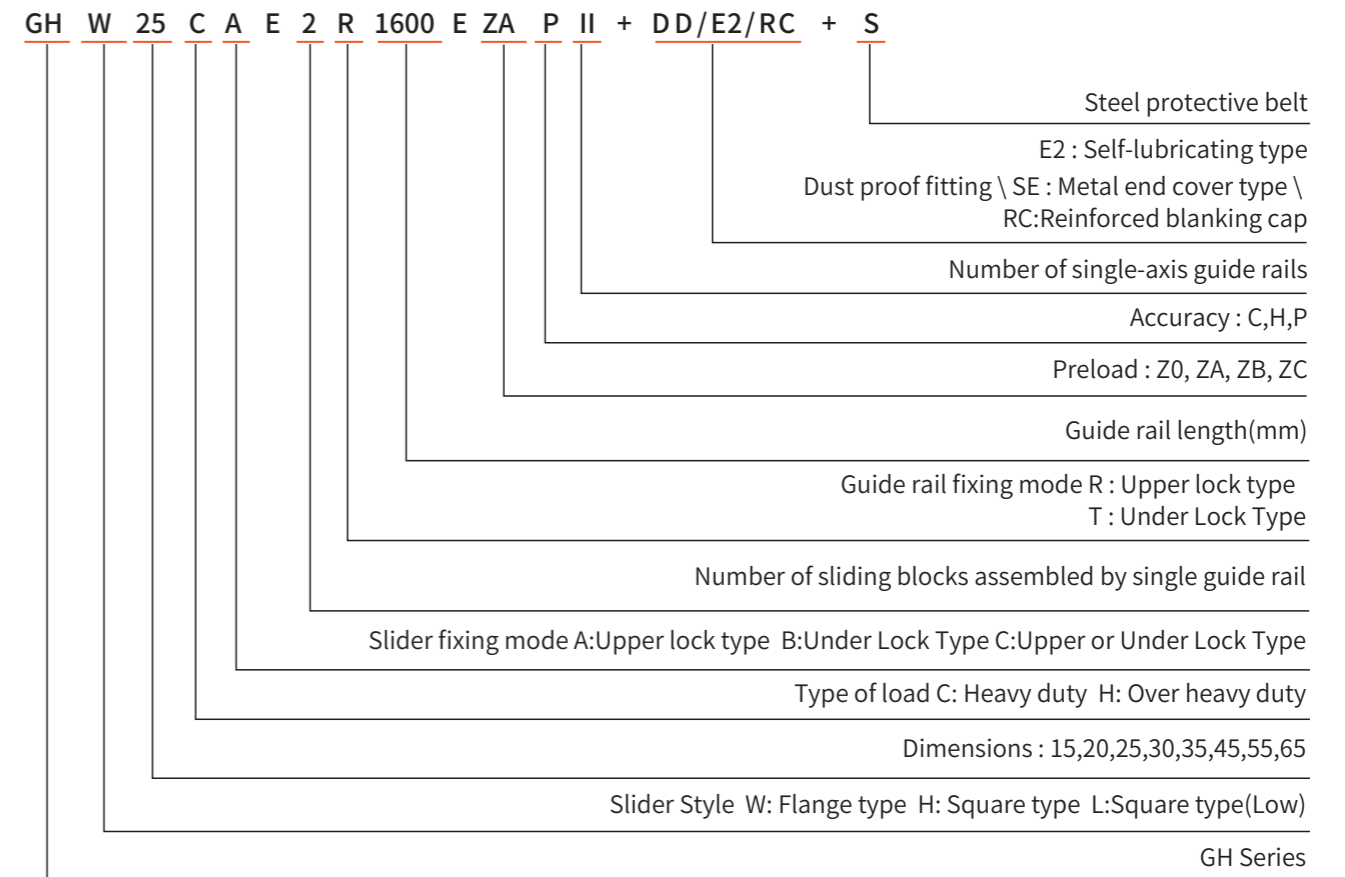

Note:

- The number of single-axis guide rails shall not be written if only — support guide rails are used. Two guide rails are marked as II, three guide rails are marked as III, and so on.
- The dust proof accessories with several weights are standard dust proof accessories with dust strip.
 ZZ: dust strip, dust strip and metal scraper.
 KK is double dust proof, dust strip and metal scraper.
 DD DUAL DUST FINS WITH DUST STRIPS.
 The sliding block type L is the low assembled sliding block of square type H, and the combined height is consistent with the flange type of the same size.

2-2-2 Product model of interchangeable linear guide rail (sliding block)

Product model of interchangeable linear guide rail (sliding block)

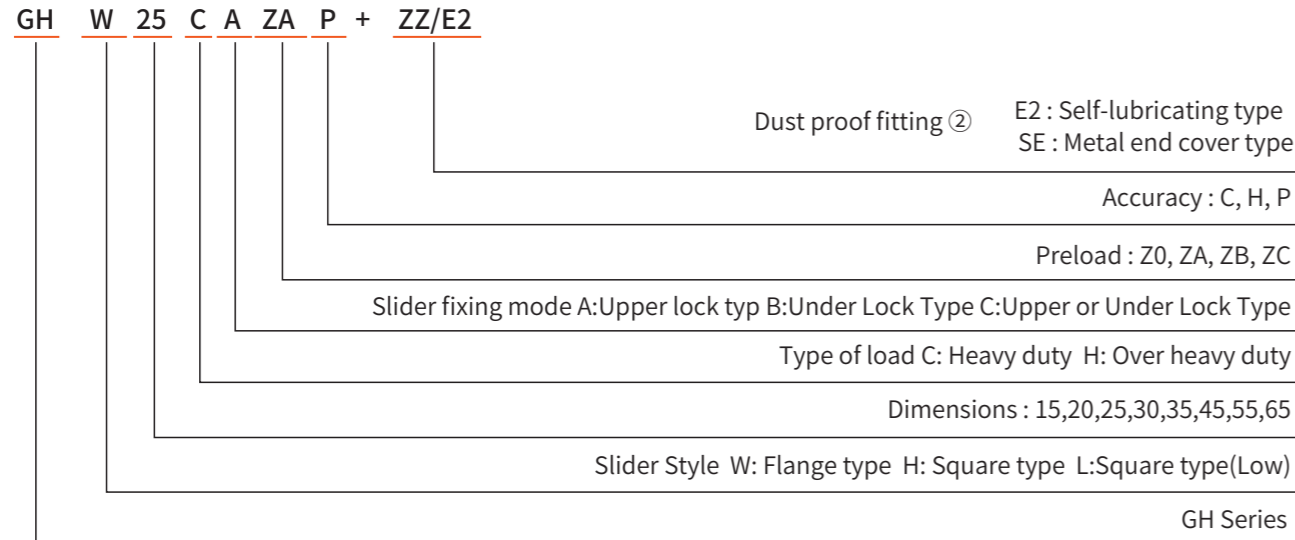

Interchangeable linear guide rail (guide rail) product model

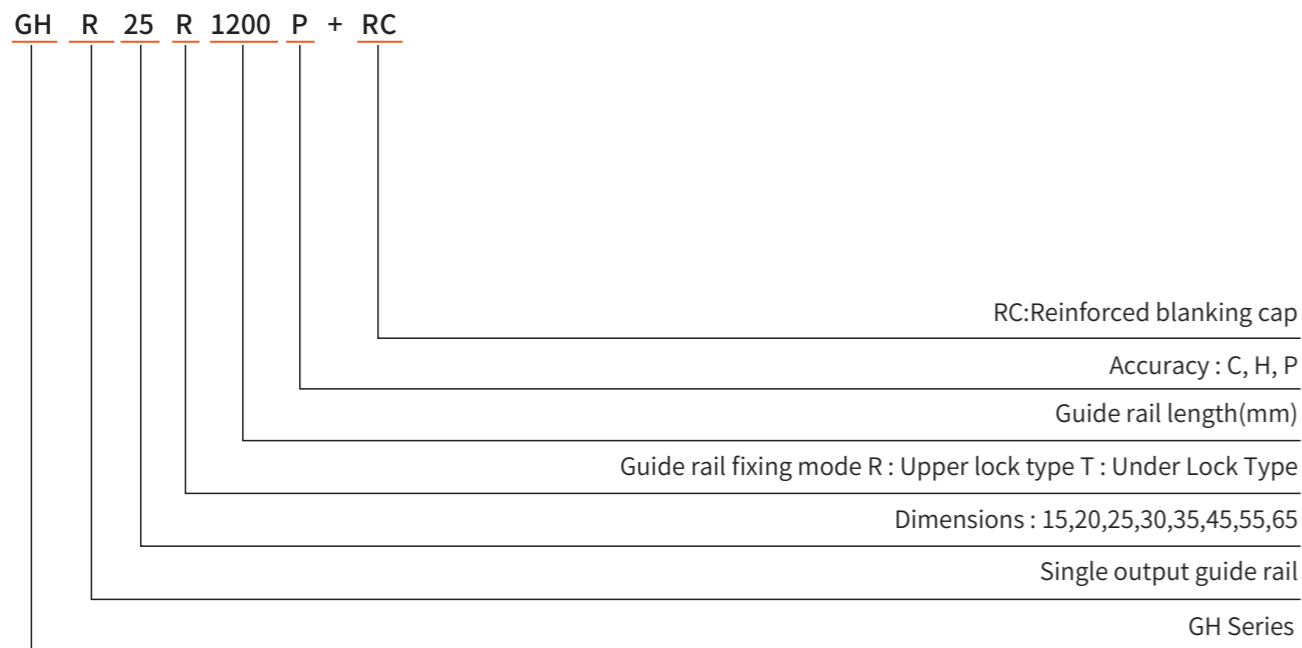

2-2-3 Recommended Applicable Equipment

NC cutting equipment: machining center machine, electric spark machine, lathe, wood-working machine, various universal equipment, etc.

Table 2-1-3

Item	Product advantages	Corresponding efficiency
1	Four row rigid	Four-row ball groove provides four-direction load capacity, improving rigidity by increasing preload
2	DF self centering	45Degree ball path contact angle with automatic strip centering for longer life and accuracy
3	Interchangeability performance	The advanced manufacturing technology and strict quality control make the dimensional tolerance of the same model stable and interchangeable
4	Pre-pressure fitting	Optional level 4 standard preload for further accuracy and rigidity
5	Dust proof accessory	Standard dust proof configuration and optional DD, KK, ZZ dust proof kit for environmental adaptability
6	Lubrication Options	Fitted with eight mounting positions, multiple nipples provide clear oil capacity and recommended oil feed rates
7	High assembly series	Standard size, high-precision and high-strength application environment, especially suitable for machine tool

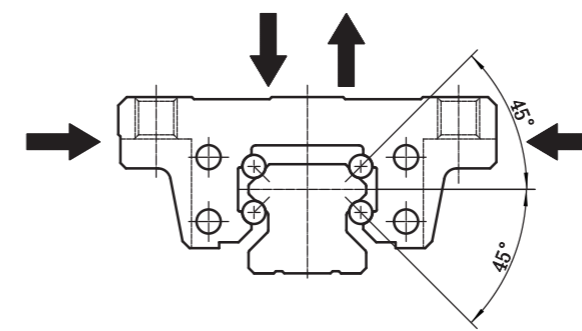

Figure 2-1-3

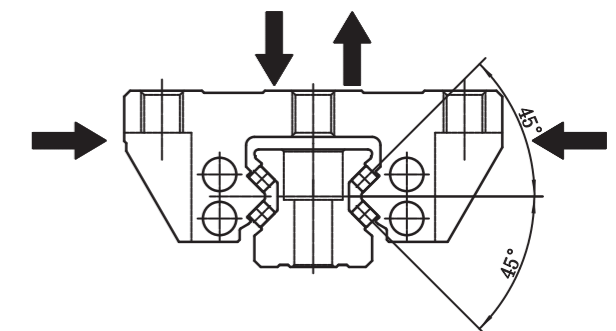
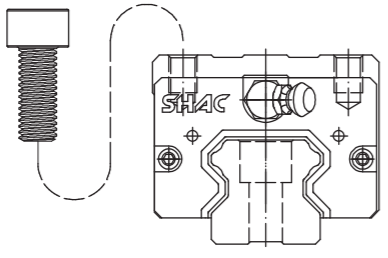
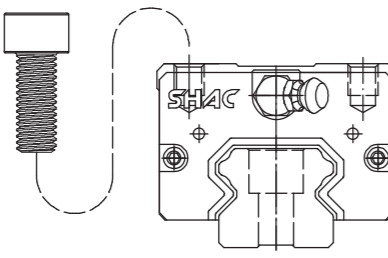
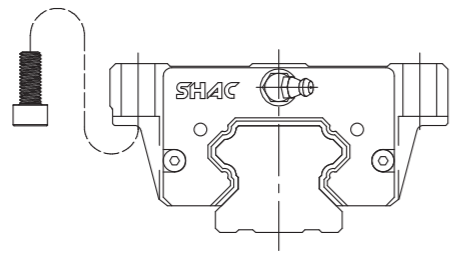
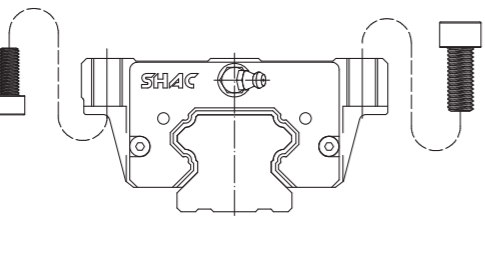

Figure 2-1-4

2-2-4 GH series slide block type

SHAC provides flange type and square type linear guide rails. The overall assembly height of flange row is lower and wider. The threaded holes and through holes machined at the flange part can meet the installation of lower lock type. The square linear guide rail is divided into H type and L type. L type is the low assembly type linear guide rail of H type, and the assembly height is the same as that of flange row linear guide rail

Table 2-1-4 Block Type

Style	Specification	SHAPE	Height dimension	Guide rail length	Equipment suitable for application
Square	GHH-CA GHH-HA		28	100	<ul style="list-style-type: none"> ● Precision adding machine ● Mechanical machining ● Heavy duty cutting machine ● Marble cutting machine ● Tools and machines ● Measuring instruments ● Grinding machine ● Punch press Ejecting machine ● Automation device ● Transport equipment
			90	6000	
Square	GHL-CA GHL-HA		24	100	
			70	6000	
Flange	GHW-CB GHW-HB		24	100	
			90	6000	
	GHW-CC GHW-HC		24	100	
			90	6000	

GH series guide rail type

In addition to the general upper locking screw hole guides, SHAC also offers locking screw hole guides from bottom locking for easy installation by the customer.

Guide rail xing mode

Upper locking screw hole guides

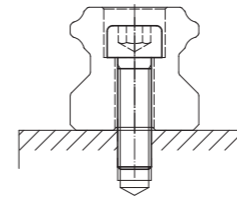

Bottom locking screw hole guides

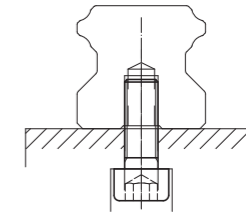
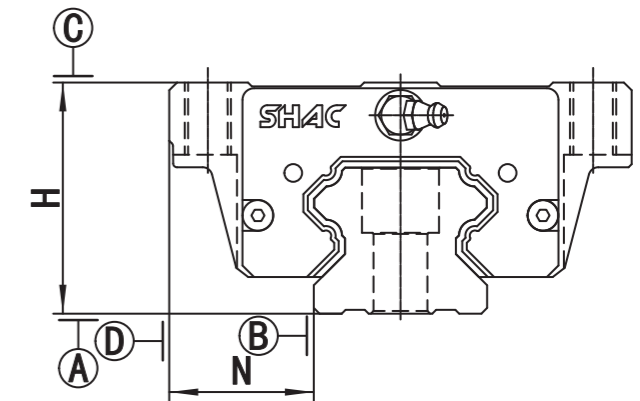

Figure 2-1-35

Grade of accuracy

The accuracy of GH series linear guide rail can be divided into five levels: common level(C), high level(H), precision level(P), ultra-precision level(SP) and ultra-high precision level(UP). Customers can select products of corresponding level according to the equipment accuracy requirements



2-2-5 Precision of non-interchangeable guide rail

Table 2-1-5 Assembly accuracy table

Unit : mm

Model No.	GH-15, 20				
Grade of accuracy	Ultra-Precision Level (UP)	Super-Precision Level (SP)	Precision Level (P)	High Level (H)	Ordinary Level (C)
Allowable dimension error of height H	0 -0.008	0 -0.015	0 -0.03	±0.03	±0.1
Allowable error of width N	0 -0.008	0 -0.015	0 -0.03	±0.03	±0.1
Mutual error of paired width H	0.003	0.004	0.006	0.01	0.02
Allowable error of paired width N	0.003	0.004	0.006	0.01	0.02
Traveling parallelism of slide block C to surface A of guide rail	Travel Parallelism (see Table 2-1-13)				
Traveling parallelism of slide block D to surface B of guide rail					

Table 2-1-6 Assembly accuracy table

Unit : mm

Model No.	GH—25, 30, 35				
Grade of accuracy	Ultra-Precision Level (UP)	Super-Precision Level (SP)	Precision Level (P)	High Level (H)	Ordinary Level (C)
Allowable dimension error of height H	0 -0.01	0 -0.02	0 -0.04	±0.04	±0.1
Allowable error of width N	0 -0.01	0 -0.02	0 -0.04	±0.04	±0.1
Mutual error of paired width H	0.003	0.005	0.007	0.015	0.02
Allowable error of paired width N	0.003	0.005	0.007	0.015	0.03
Traveling parallelism of slide block C to surface A of guide rail	Travel Parallelism (see Table 2-1-13)				
Traveling parallelism of slide block D to surface B of guide rail					

Table 2-1-7 Assembly accuracy table

Unit : mm

Model No.	GH—45, 55				
Grade of accuracy	Ultra-Precision Level (UP)	Super-Precision Level (SP)	Precision Level (P)	High Level (H)	Ordinary Level (C)
Allowable dimension error of height H	0 -0.02	0 -0.03	0 -0.05	±0.05	±0.1
Allowable error of width N	0 -0.02	0 -0.03	0 -0.05	±0.05	±0.1
Mutual error of paired width H	0.003	0.005	0.007	0.015	0.03
Allowable error of paired width N	0.005	0.007	0.01	0.02	0.03
Traveling parallelism of slide block C to surface A of guide rail	Travel Parallelism (see Table 2-1-13)				
Traveling parallelism of slide block D to surface B of guide rail					

Table 2-1-8 Assembly accuracy table

Unit : mm

Model No.	GH—65				
Grade of accuracy	Ultra-Precision Level (UP)	Super-Precision Level (SP)	Precision Level (P)	High Level (H)	Ordinary Level (C)
Allowable dimension error of height H	0 -0.03	0 -0.05	0 -0.07	±0.07	±0.1
Allowable error of width N	0 -0.03	0 -0.05	0 -0.07	±0.07	±0.1
Mutual error of paired width H	0.005	0.007	0.01	0.02	0.03
Allowable error of paired width N	0.007	0.01	0.015	0.025	0.03
Traveling parallelism of slide block C to surface A of guide rail	Travel Parallelism (see Table 2-1-13)				
Traveling parallelism of slide block D to surface B of guide rail					

2-2-6 Interchangeability guide rail accuracy

Table 2-1-9 Assembly accuracy table

Unit : mm

Model No.	GH—15, 20		
Grade of accuracy	Precision Level (P)	High Level (H)	Ordinary Level (C)
Allowable dimension error of height H	0 -0.04	±0.04	±0.1
Allowable error of width N	0 -0.04	±0.04	±0.1
Mutual error of paired width H	0.007	0.015	0.02
Allowable error of paired width N	0.007	0.015	0.03
Traveling parallelism of slide block C to surface A of guide rail	Travel Parallelism (see Table 2-1-13)		
Traveling parallelism of slide block D to surface B of guide rail			

Table 2-1-10 Assembly accuracy table

Unit : mm

Model No.	GH—25, 30, 35		
Grade of accuracy	Precision Level (P)	High Level (H)	Ordinary Level (C)
Allowable dimension error of height H	±0.02	±0.04	±0.1
Allowable error of width N	±0.02	±0.04	±0.1
Mutual error of paired width H	0.007	0.015	0.02
Allowable error of paired width N	0.007	0.015	0.03
Traveling parallelism of slide block C to surface A of guide rail	Travel Parallelism (see Table 2-1-13)		
Traveling parallelism of slide block D to surface B of guide rail			

Table 2-1-11 Assembly accuracy table

Unit : mm

Model No.	GH—45, 55		
Grade of accuracy	Precision Level (P)	High Level (H)	Ordinary Level (C)
Allowable dimension error of height H	±0.025	±0.05	±0.1
Allowable error of width N	±0.025	±0.05	±0.1
Mutual error of paired width H	0.007	0.015	0.03
Allowable error of paired width N	0.01	0.02	0.03
Traveling parallelism of slide block C to surface A of guide rail	Travel Parallelism (see Table 2-1-13)		
Traveling parallelism of slide block D to surface B of guide rail			

Table 2-1-12 Assembly accuracy table

Unit : mm

Model No.	GH-65		
Grade of accuracy	Precision Level (P)	High Level (H)	Ordinary Level (C)
Allowable dimension error of height H	±0.035	±0.07	±0.1
Allowable error of width N	±0.035	±0.07	±0.1
Mutual error of paired width H	0.01	0.02	0.03
Allowable error of paired width N	0.015	0.025	0.03
Traveling parallelism of slide block C to surface A of guide rail	Travel Parallelism (see Table 2-1-13)		
Traveling parallelism of slide block D to surface B of guide rail			

2-2-7 Traveling parallel precision

Table 2-1-13

Unit : mm

Guide rail length (mm)	Grade of accuracy (μm)				
	UP	SP	P	H	C
~	2	2	3	7	12
100~200	2	2	4	9	14
200~300	2	3	5	10	15
300~500	2	3	6	12	17
500~700	2	4	7	13	20
700~900	3	5	8	15	22
900~1100	3	6	9	16	24
1100~1500	4	7	11	18	26
1500~1900	4	8	13	20	28
1900~2500	5	10	15	22	31
2500~3100	6	11	18	25	33
3100~3600	7	14	20	27	36
3600~4000	7	15	21	28	37

Preload

The so-called preloading is to increase the diameter of the steel ball to produce negative pressure between the steel ball and the channel. Clearances, pre-applied loads internally. Clearance is not only eliminated by assembly with preload. It can also improve the rigidity and precision of the sliding block.

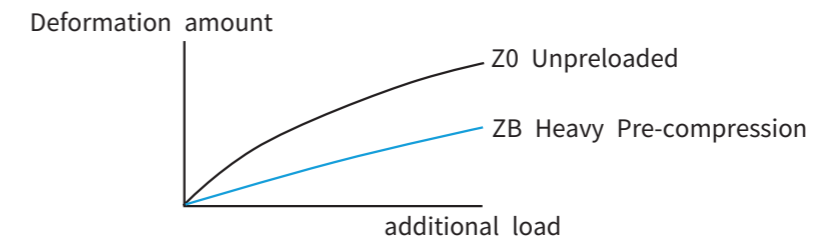

Figure 2-1-7

2-2-8 Grade of Preload

Table 2-1-14 Grade of preload

Degree of preload	Code	Preload	Service conditions	Scopes of application
No preload	Z0	0~0.02C	Fixed load direction, small impact and low precision requirements	Automatic packing machine, handling device, welding machine, automatic machinery, tool exchange device
Light preload	ZA	0.02C~0.04C	Light duty and high accuracy required	Z-axis of general industrial machinery, NC lathe, shop spark machine, measuring device, precise XY platform, vertical machining center, industrial robot, various high-speed material supply devices, etc
Medium preload	ZB	0.04C~0.08C	High rigidity, vibration and impact environment	Z-axis of machine tool, NC lathe, grinder, vertical or horizontal milling machine, re-cutting machine, etc
Heavy preload	ZC	0.08C~0.12C	It requires higher rigidity and has a service environment with large vibration and impact	Machining centers, heavy-duty cutting machines, etc
Assembly mode	Non-interchangeable track (single output)			Non-interchangeable track (single output)
Grade of preload	Z0, ZA			Z0, ZA, ZB, ZC

2-2-9 Way of lubrication

Grease lubrication

See pages 26 and 27 for choke style

Oil nozzle position

Location of choke: we can install choke at the front end or rear end of the slider according to customer requirements, and the side of the end cover is also reserved with the location of choke mounting hole for the convenience of oil injection from the side. According to different injection methods, the choke can be divided into common choke and special oil pipe connector

©See pages 29, 30 for nozzle details

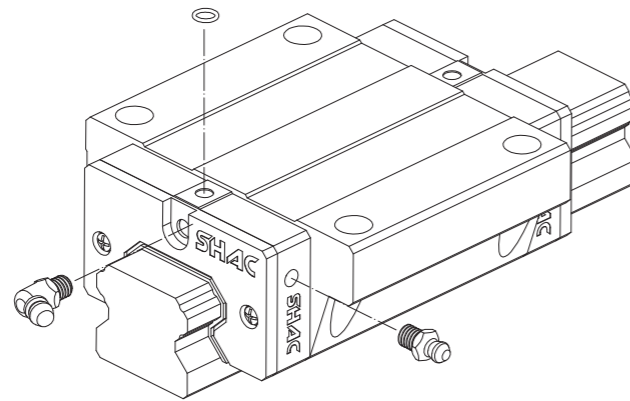

Figure 2-1-8

Table 2-1-15 O-Ring Size and Maximum Allowable Depth

Specification	O-Ring Size		Maximum Allowable Depth T_{max} (mm)
	do (mm)	W (mm)	
GH15	2.5±0.15	1.5±0.15	3.75
GH20	4.5±0.15	1.5±0.15	5.7
GH25	4.5±0.15	1.5±0.15	5.8
GH30	4.5±0.15	1.5±0.15	6.3
GH35	4.5±0.15	1.5±0.15	8.8
GH45	4.5±0.15	1.5±0.15	8.2
GH55	4.5±0.15	1.5±0.15	11.8
GH65	4.5±0.15	1.5±0.15	10.8

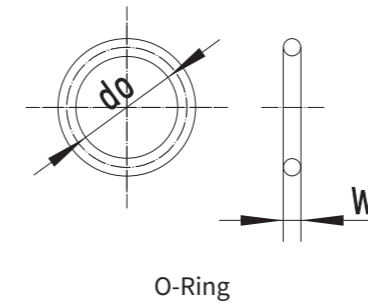

Figure 2-1-9

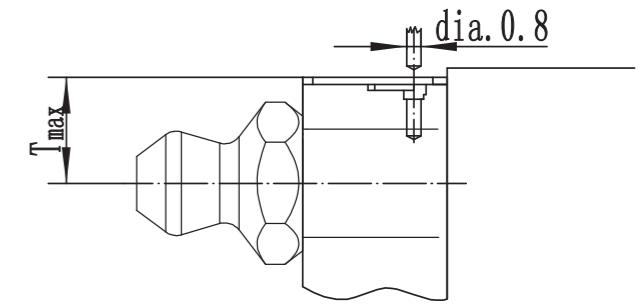

Figure 2-1-10

2-2-10 Lubricating oil capacity of single sliding block

Table 2-1-16

Specification	CA (cm ³)	HA (cm ³)	Specification	CA (cm ³)	HA (cm ³)
GH15	1	-	GH35	10	12
GH20	2	3	GH45	17	21
GH25	5	6	GH55	26	33
GH30	7	8	GH65	50	61

2-2-11 Lubrication mode and frequency

Oil feed rate

Table 2-1-17

Specification	Oil feed rate (cm ³ /hr)	Specification	Oil feed rate (cm ³ /hr)
GH15	0.2	GH35	0.3
GH20	0.2	GH45	0.4
GH25	0.3	GH55	0.5
GH30	0.3	GH65	0.6

2-2-12 Dust-proof fitting and code

Generally, the standard dustproof is used in the operating environment without special requirements. If the following dustproof accessories are required, please mark the code behind the product model.

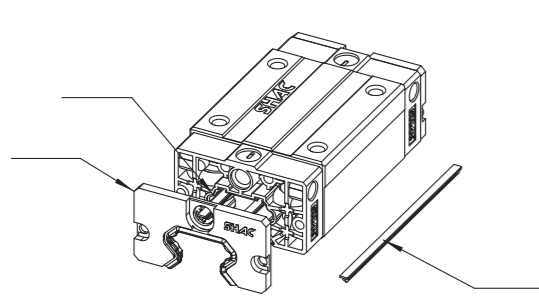

Figure 2-1-11

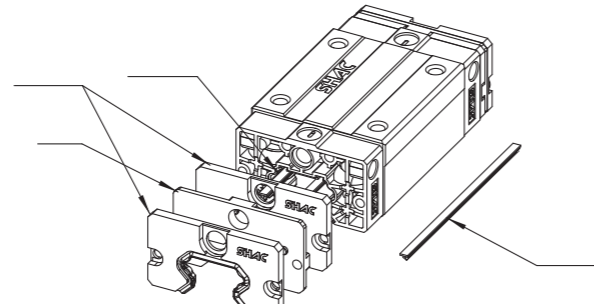

Figure 2-1-12

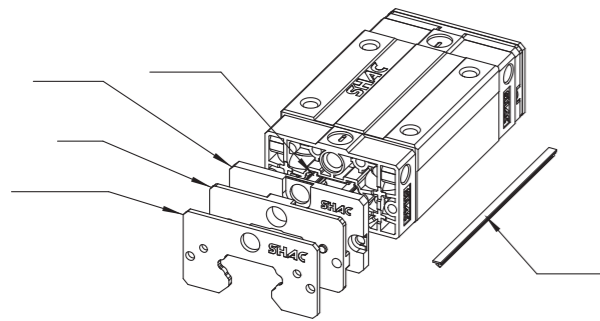

Figure 2-1-13

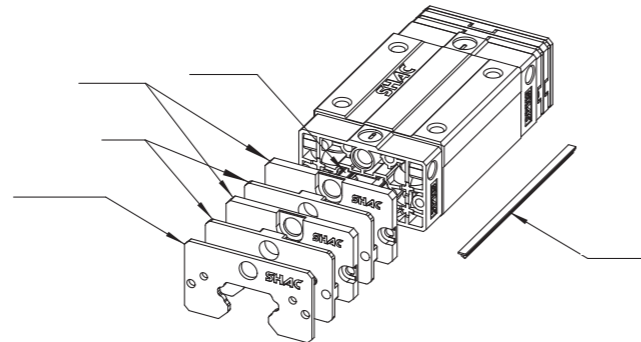

Figure 2-1-14

TOTAL SLIDE LENGTH PER DUST CODE (mm)

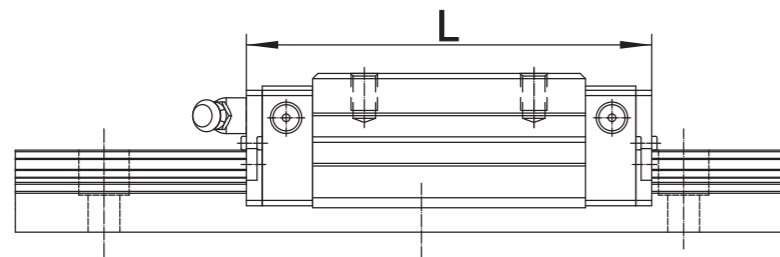

Figure 2-1-15

Table 2-1-18

TOTAL SLIDE LENGTH PER DUST CODE (mm)				
Specification	Standard	ZZ	DD	KK
GH15C	59.5	65.5	66.5	72.5
GH20C	74.5	80.5	81.5	87.5
GH20H	89.2	95.2	96.2	102.2
GH25C	82	88.2	89.2	95.4
GH25H	102.6	108.8	109.8	116
GH30C	96	102	103	109
GH30H	119	125	126	132
GH35C	110.6	117	118.6	125
GH35H	136.4	142.8	144.4	150.8
GH45C	135.4	142	145	151.6
GH45H	167.2	173.8	176.8	183.4
GH55C	161.9	169.9	172.9	180.9
GH55H	200	208	211	219
GH65C	194.2	202.2	205.2	213.2
GH65H	253.6	261.6	264.6	272.6

Table 2-1-19

L series dustproof code slider total length (mm)				
Size	Standard	ZZ	DD	KK
LH15C	60	66.2	67.2	73.4
LH20C	75	81	82	88
LH20H	89.2	95.2	96.2	102.2
LH25C	84.4	89.8	90.8	96.2
LH25H	105.9	111.3	112.3	117.7
LH30C	97.5	102.9	103.9	109.3
LH30H	120	125.4	126.4	131.8

Friction force

The resistance value in the following table is the maximum resistance of two dust sheets

Table 2-1-19 Resistance value of GH series dust strip

Unit : n

Specification	Standard dust vane resistance (kgf)	Specification	Standard dust vane resistance (kgf)	Resistance of heavy preloaded dust strip (kgf)
GH15	1.5 (0.15)	GH35	4.5 (0.46)	-
GH20	2.55 (0.26)	GH45	6 (0.61)	8 (0.81)
GH25	3.00 (0.3)	GH55	6.9 (0.7)	10 (1.00)
GH30	3.9 (0.4)	GH65	8.7 (0.89)	12 (1.2)

Note : 1kgf = 0.81N

2-2-13 Allowable error of mounting surface

Due to the DF (45 ° - 45 °) combined structure of the arc groove, it has the ability of automatic centering. Even if there is a certain deviation on the installation surface, it can automatically achieve a balanced state, maintain a stable, high-precision linear motion, and greatly improve the negative service life and accuracy of the guide rail.

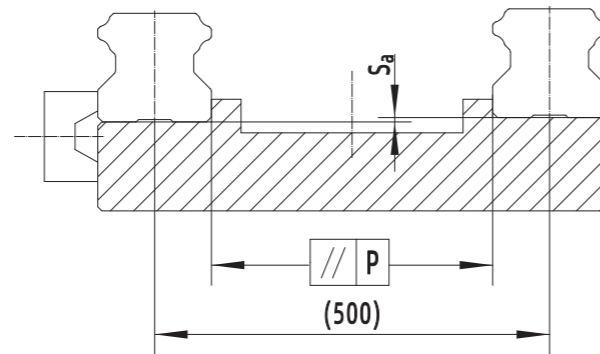

Figure 2-1-16

Table 2-1-20 Allowable parallelism error (P)

Unit: μm

Specification	Preload		
	Z0	ZA	ZB
GH15	25	18	13
GH20	25	20	18
GH25	30	22	20
GH30	40	30	27
GH35	50	35	30
GH45	60	40	35
GH55	70	50	45
GH65	80	60	55

Note: The allowable value is directly proportional to the distance between two guide rails

Table 2-1-21 Allowable upper and lower parallelism error (Sa)

Unit: μm

Specification	Preload		
	Z0	ZA	ZB
GH15	130	85	35
GH20	130	85	50
GH25	130	85	70
GH30	170	110	90
GH35	210	150	120
GH45	250	170	140
GH55	300	210	170
GH65	350	250	200

2-2-14 Precautions for installation

Height and chamfer of bearing surface

When installing the linear guide rail, pay attention to whether the size of the bearing surface is appropriate. For example, excessive chamfer will cause the guide rail and the bearing surface unable to be completely contacted, It is easy to cause poor accuracy of linear guide rail. However, if the bearing surface is too high, it will conflict with the bottom height of the sliding block, so it cannot be installed.

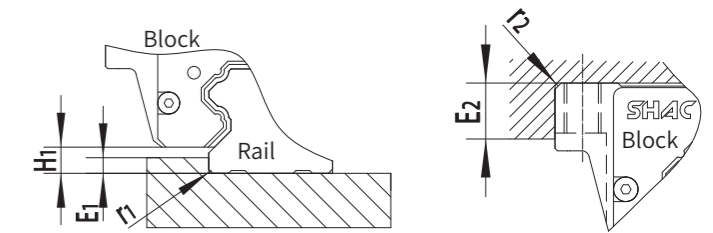

Figure 2-1-17

Table 2-1-22 Height of bearing surface and chamfer

Specification	Maximum guide rail end r_1 (mm)	Max. slide end Radius of fillet r_2 (mm)	Guide rail end bearing Height of abutting surface E_1 (mm)	Slide end bearing Height of abutting surface E_2 (mm)	Clear height of slide block H_1 (mm)	Chamfer dimensions for linear guide
						A/B
GH15	0.5	0.5	3.0	4.0	4.3	0.9
GH20	0.5	0.5	3.5	5.0	4.6	1.2
GH25	1.0	1.0	4.0	5.0	5.5	1.2
GH30	1.0	1.0	4.5	5.0	6.0	1.5
GH35	1.0	1.0	6.0	6.0	7.5	1.7
GH45	1.0	1.0	8.0	8.0	9.5	1.7
GH55	1.5	1.5	10.0	10.0	13.0	2
GH65	1.5	1.5	10.0	10.0	15.0	2

2-2-14 Specification and torsion of guide rail mounting screw

The locking force of the mounting screws of the linear guide rail directly affects the service life and accuracy of the guide rail. Therefore, it is important to use a torque wrench to lock each screw with an appropriate torque value.

Table 2-1-23 Torque Values

Specification	Screw Size	Torque value N-cm (kgf-cm)		
		Iron parts	Casting	Aluminium alloy
GH15	M4×0.7P×16L	392 (40)	274 (28)	206 (21)
GH20	M5×0.8P×16L	883 (90)	588 (60)	441 (45)
GH25	M6×1P×20L	1373 (140)	921 (94)	686 (70)
GH30	M8×1.25P×25L	3041 (310)	2010 (205)	1470 (150)
GH35	M8×1.25P×25L	3041 (310)	2010 (205)	1470 (150)
GH45	M12×1.75P×35L	11772 (1200)	7840 (800)	5880 (600)
GH55	M14×2P×45L	15696 (1600)	10500 (1100)	7840 (800)
GH65	M16×2P×50L	19620 (2000)	13100 (1350)	9800 (1000)

GH Series - Heavy Duty Ball Linear Guide

(1) GHH-CA / GHH-HA

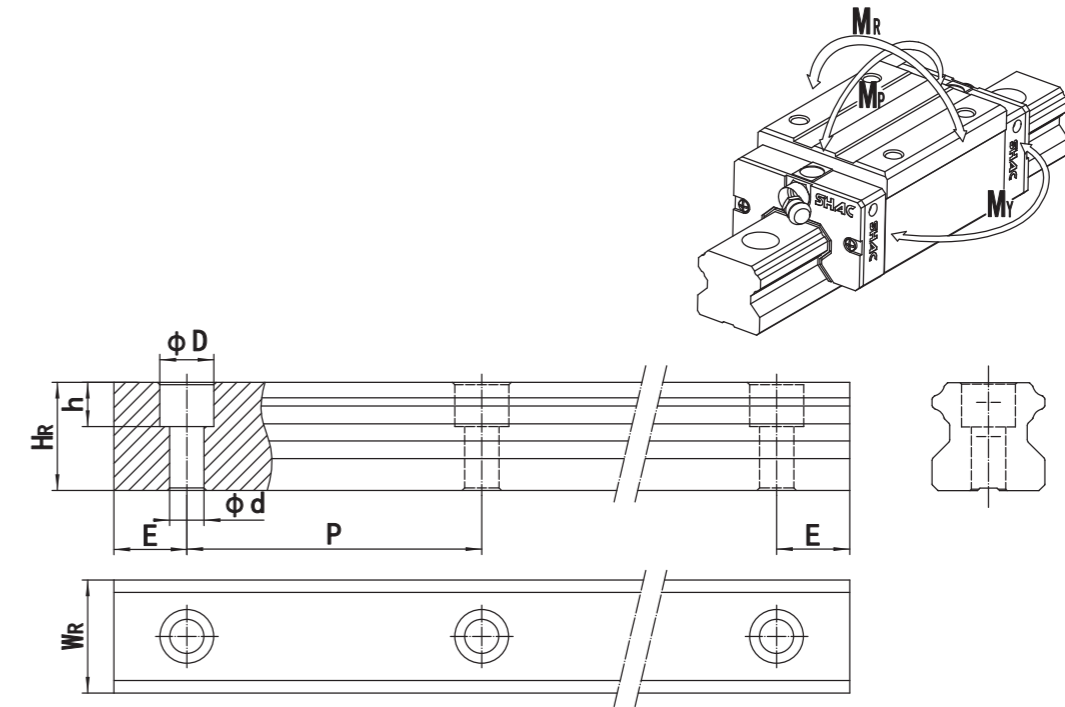
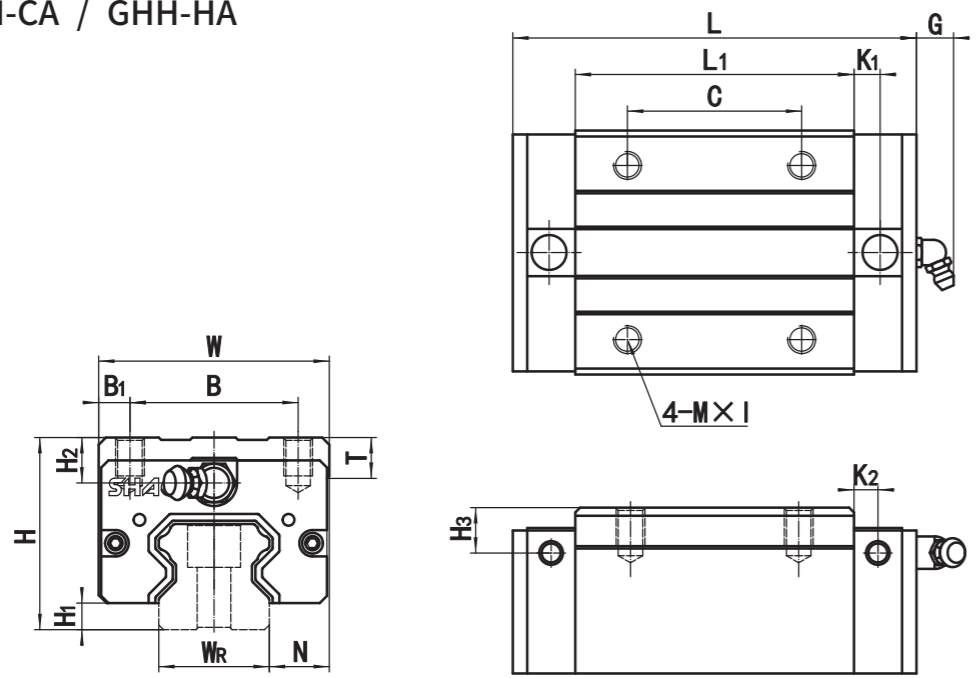

Model No.	Dimensions of Assembly (mm)			Dimensions of Block (mm)													
	H	H ₁	N	W	B	B ₁	C	L ₁	L	K ₁	K ₂	G	M*I	T	H ₂	H ₃	
GHH15CA	28	4.4	9.5	34	26	4	26	39.5	59.5	3.35	4.75	5.5	M4×5	6	8	8	
GHH20CA	30	4.3	12	44	32	6	36	50.5	74.5	5	6	12	M5×6	8	6	6	
GHH20HA							50	65.2	89.2								
GHH25CA	40	5.6	12.5	48	35	6.5	35	58	82	5	6	12	M6×8	8	10	9.5	
GHH25HA							50	78.6	102.6								
GHH30CA	45	5.5	16	60	40	10	40	70	96	6.5	5.5	12	M8×10	8.5	10	9	
GHH30HA							60	93	119								
GHH35CA	55	7.4	18	70	50	10	50	80	110.6	5.5	6.5	12	M8×12	10.2	16	15	
GHH35HA							72	105.8	136.4								
GHH45CA	70	9.5	20.5	86	60	13	60	97	135.4	4.8	8	13	M10×17	16	21	20	
GHH45HA							80	128.8	167.2								
GHH55CA	80	13	23.5	100	75	12.5	75	117.7	161.9	6	11	13	M12×18	17.5	22	29	
GHH55HA							95	155.8	200								
GHH65CA	90	15	31.5	126	76	25	70	144.2	194.2	6	14	13	M16×20	25	15	15	
GHH65HA							120	203.6	253.6								

Note : 1kgf = 9.81N

Model No.	Dimensions of Rail(mm)							Mounting Boit for Rail (mm)	Basic Dynamic load Rating (KN)	Basic Static load Rating (KN)	Static Rated Monent			Weight	
	W _r	H _r	D	h	d	P	E				C (KN)	C ₀ (KN)	M _r KN-m	M _p KN-m	M _v KN-m
GH15	15	15	7.5	5.3	4.5	60	20	M4×16	14.26	22.88	0.12	0.10	0.10	0.19	1.42
GH20	20	17.5	9.5	8.5	6	60	20	M5×16	26.29	35.76	0.26	0.20	0.20	0.33	2.2
									31.72	46.76	0.34	0.34	0.34	0.41	
GH25	23	22	11	9	7	60	20	M6×20	33.85	51.5	0.41	0.32	0.32	0.53	3.25
									40.93	67.34	0.55	0.56	0.56	0.71	
GH30	28	26	14	12	9	80	20	M8×25	47.77	70.79	0.65	0.52	0.52	0.92	4.49
									57.72	92.58	0.86	0.9	0.9	1.20	
GH35	34	29	14	12	9	80	20	M8×25	63.63	92.47	1.14	0.79	0.79	1.53	6.36
									76.73	120.93	1.51	1.37	1.37	2.0	
GH45	45	38	20	17	14	105	22.5	M12×35	102.24	144.51	1.94	1.52	1.52	2.82	10.45
									123.42	188.97	2.58	2.63	2.63	3.7	
GH55	53	44	23	20	16	120	30	M14×45	150.14	207.01	3.62	2.59	2.59	3.48	15.12
									181.2	270.71	4.78	4.48	4.48	4.52	
GH65	63	53	26	22	18	150	35	M16×50	208.94	281.73	6.52	4.18	4.18	7.56	21.25
									272.24	411.77	9.19	7.23	7.23	10.5	

Note : 1kgf = 9.81N

GH Series - Heavy Duty Ball Linear Guide

(2) GHL-CA / GHL-HA

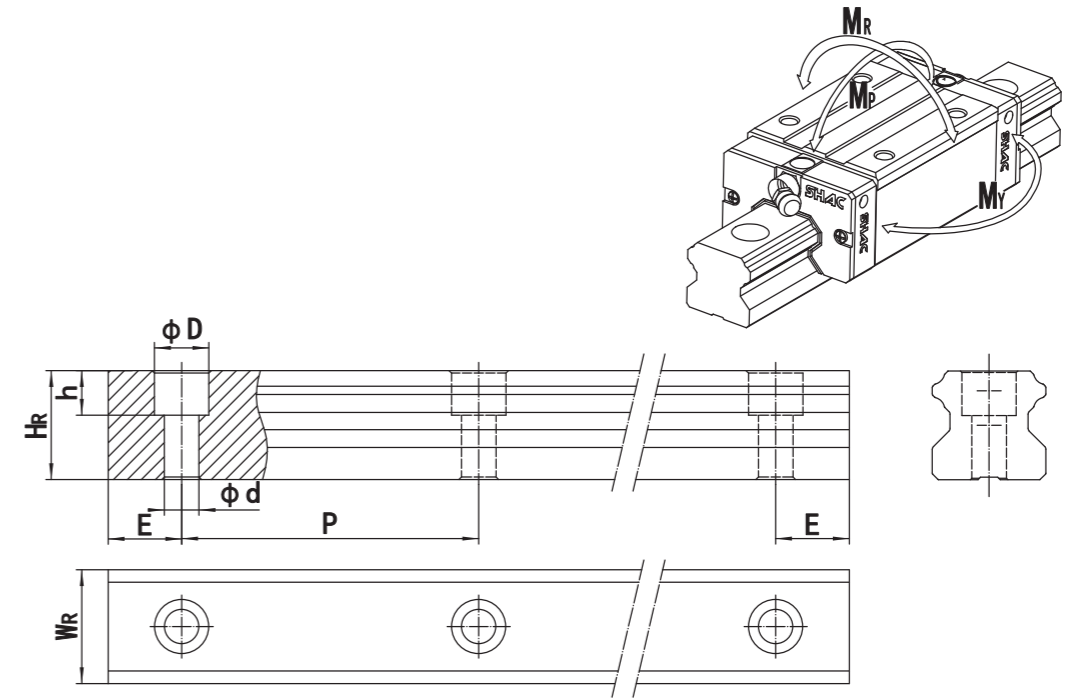
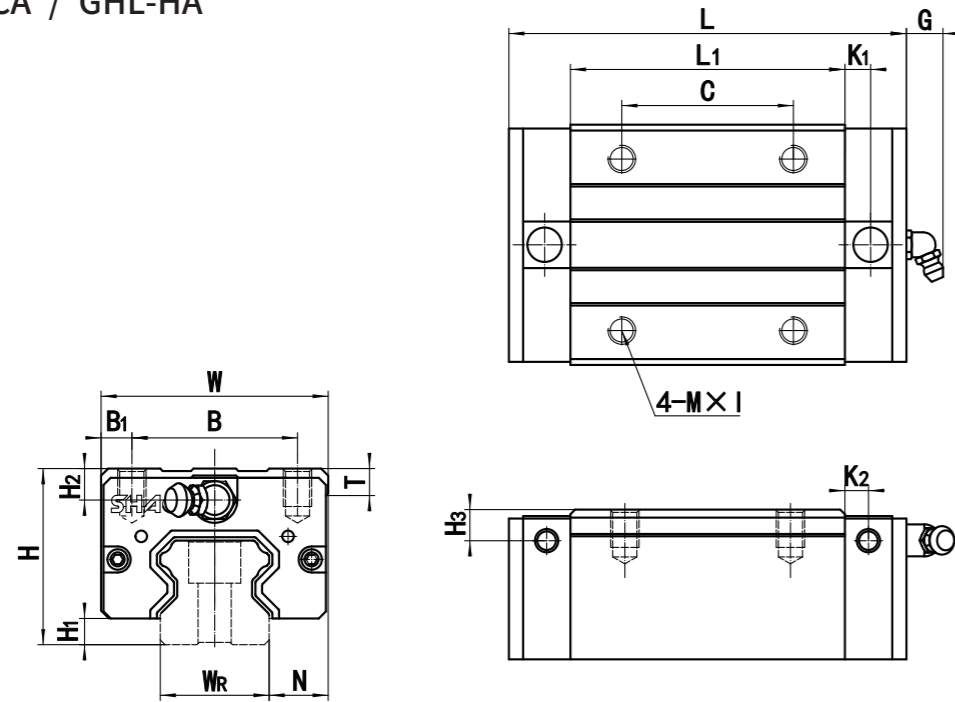

Model No.	Dimensions of Assembly (mm)			Dimensions of Block (mm)												
	H	H ₁	N	W	B	B ₁	C	L ₁	L	K ₁	K ₂	G	M* <i>l</i>	T	H ₂	H ₃
GHL15CA	24	4.4	9.5	34	26	4	26	39.5	59.5	3.35	4.75	5.5	M4×4	2	4	4
GHL25CA	36	5.6	12.5	48	35	6.5	35	58	82	5	6	12	M6×6	4	6	5.5
GHL25HA							50	78.6	102.6							
GHL30CA	42	5.5	16	60	40	10	40	70	96	6.5	5.5	12	M8×9	5.5	7	6
GHL30HA							60	93	119							
GHL35CA	48	7.4	18	70	50	10	50	80	110.6	5.5	6.5	12	M8×9	3.2	9	8
GHL35HA							72	105.8	136.4							
GHL45CA	60	9.5	20.5	86	60	13	60	97	135.4	4.8	8	13	M10×13	6	11	10
GHL45HA							80	128.8	167.2							
GHL55CA	70	13	23.5	100	75	12.5	75	117.7	161.9	6	11	13	M12×18	7.5	12	19
GHL55HA							95	155.8	200							

Note : 1kgf = 9.81N

Model No.	Dimensions of Rail(mm)							Mounting Bolt for Rail (mm)	Basic Dynamic load Rating C (KN)	Basic Static load Rating C0 (KN)	Static Rated Moment			Weight	
	W _R	H _R	D	h	d	P	E				M _R KN-m	M _P KN-m	M _V KN-m	Block kg	Rail kg/m
GH15	15	15	7.5	5.3	4.5	60	20	M4×16	14.26	22.88	0.12	0.10	0.10	0.15	1.42
GH25	23	22	11	9	7	60	20	M6×20	33.85	51.5	0.41	0.32	0.32	0.44	3.25
									40.93	67.34	0.55	0.56	0.56	0.62	
GH30	28	26	14	12	9	80	20	M8×25	47.77	70.79	0.65	0.52	0.52	0.82	4.49
									57.72	92.58	0.86	0.9	0.9	1.1	
GH35	34	29	14	12	9	80	20	M8×25	63.63	92.47	1.14	0.79	0.79	1.22	6.36
									76.73	120.93	1.51	1.37	1.37	1.69	
GH45	45	38	20	17	14	105	22.5	M12×35	102.24	144.51	1.94	1.52	1.52	2.17	10.45
									123.42	188.97	2.58	2.63	2.63	3.05	
GH55	53	44	23	20	16	120	30	M14×45	150.14	207.01	3.62	2.59	2.59	2.56	15.12
									181.2	270.71	4.78	4.48	4.48	3.3	

Note : 1kgf = 9.81N

GH Series - Heavy Duty Ball Linear Guide

(3) GHW-CA / GHW-HA

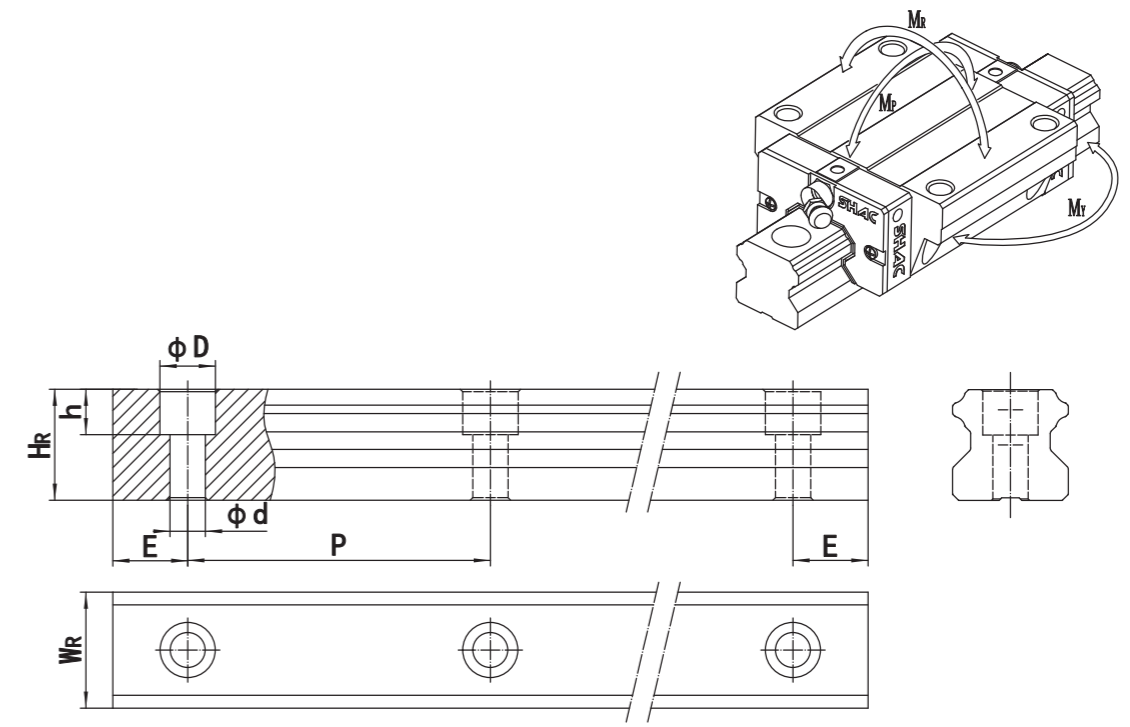
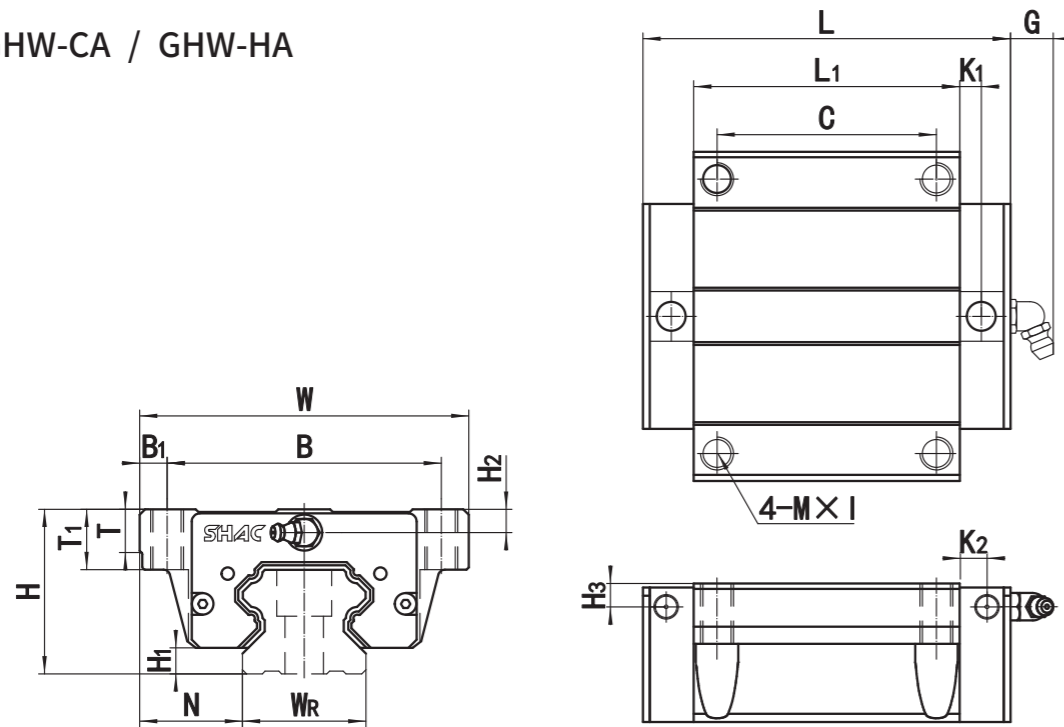

Model No.	Dimensions of Assembly (mm)			Dimensions of Block (mm)													
	H	H ₁	N	W	B	B ₁	C	L ₁	L	K ₁	K ₂	G	M	T	T ₁	H ₂	H ₃
GHW15CA	24	4.4	16	47	38	4.5	30	39.5	59.5	3.35	4.75	5.5	M5	6	8.9	4	4
GHW20CA	30	4.3	21.5	63	53	5	40	50.5	74.5	5	6	12	M6	8	10	6	6
GHW20HA								65.2	89.2								
GHW25CA	36	5.6	23.5	70	57	6.5	45	58	82	5	6	12	M8	8	14	6	5.5
GHW25HA								78.6	102.6								
GHW30CA	42	5.5	31	90	72	9	52	70	96	6.5	5.5	12	M10	8.5	16	7	6
GHW30HA								93	119								
GHW35CA	48	7.4	33	100	82	9	62	80	110.6	5.5	6.5	12	M10	10.2	18	9.2	8.5
GHW35HA								105.8	136.4								
GHW45CA	60	9.5	37.5	120	100	10	80	97	135.4	4.8	8	13	M12	16	22	11	10
GHW45HA								128.8	167.2								
GHW55CA	70	13	43.5	140	116	12	95	117.7	161.9	6	11	13	M14	17.5	26.5	12	19
GHW55HA								155.8	200								
GHW65CA	90	15	53.5	170	142	14	110	144.2	194.2	6	14	13	M16	25	37.5	15	15
GHW65HA								203.6	253.6								

Note : 1kgf = 9.81N

Model No.	Dimensions of Rail(mm)							Mounting Boit for Rail (mm)	Basic Dynamic load Rating C (KN)	Basic Static load Rating C0 (KN)	Static Rated Monent			Weight	
	W _R	H _R	D	h	d	P	E				M _R KN-m	M _P KN-m	M _V KN-m	Block kg	Rail kg/m
GH15	15	15	7.5	5.3	4.5	60	20	M4×16	14.26	22.88	0.12	0.10	0.10	0.18	1.42
GH20	20	17.5	9.5	8.5	6	60	20	M5×16	26.29	35.76	0.26	0.20	0.20	0.41	2.2
									31.72	46.76	0.34	0.34	0.34	0.52	
GH25	23	22	11	9	7	60	20	M6×20	33.85	51.5	0.41	0.32	0.32	0.58	3.25
									40.93	67.34	0.55	0.56	0.56	0.78	
GH30	28	26	14	12	9	80	20	M8×25	47.77	70.79	0.65	0.52	0.52	1.05	4.49
									57.72	92.58	0.86	0.9	0.9	1.4	
GH35	34	29	14	12	9	80	20	M8×25	63.63	92.47	1.14	0.79	0.79	1.55	6.36
									76.73	120.93	1.51	1.37	1.37	2.06	
GH45	45	38	20	17	14	105	22.5	M12×35	102.24	144.51	1.94	1.52	1.52	2.73	10.45
									123.42	188.97	2.58	2.63	2.63	3.65	
GH55	53	44	23	20	16	120	30	M14×45	150.14	207.01	3.62	2.59	2.59	4.5	15.12
									181.2	270.71	4.78	4.48	4.48	5.94	
GH65	63	53	26	22	18	150	35	M16×50	208.94	281.73	6.52	4.18	4.18	9.35	21.25
									272.24	411.77	9.19	7.23	7.23	13.25	

Note : 1kgf = 9.81N

GH Series - Heavy Duty Ball Linear Guide

(4) GHW-CB / GHW-HB

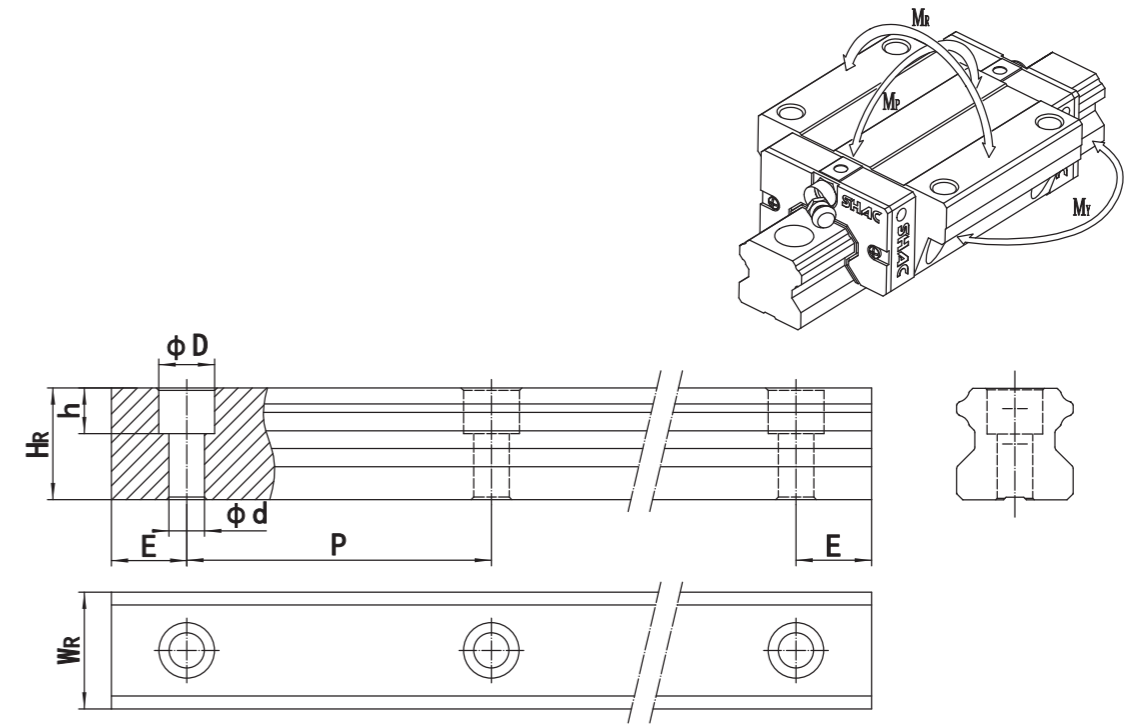
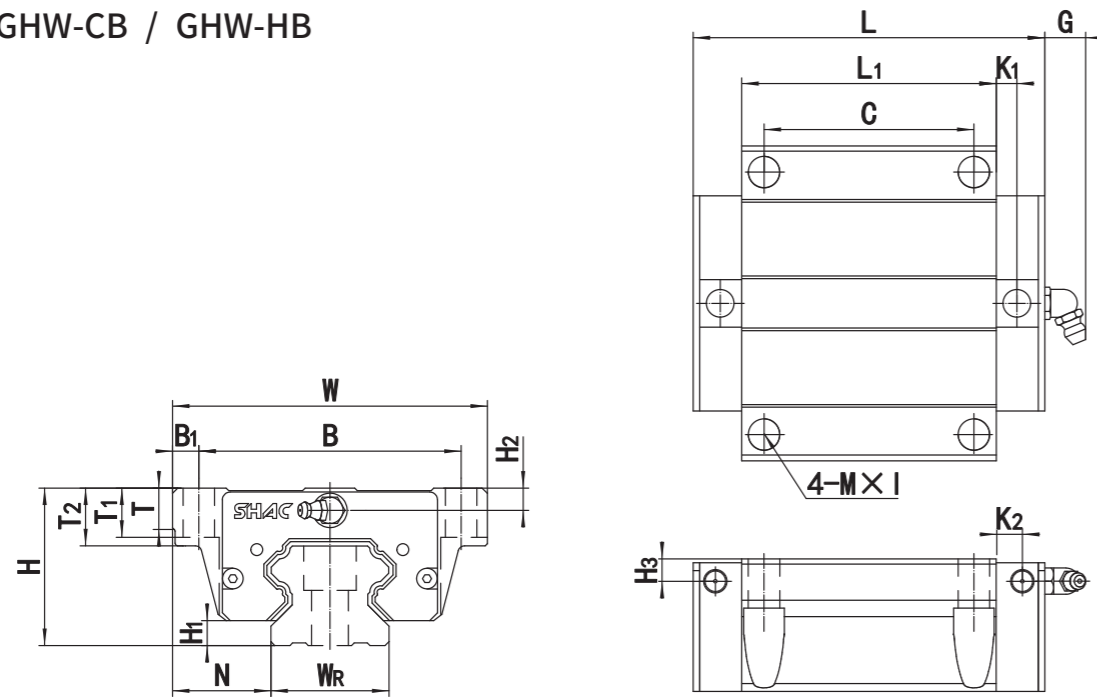

Model No.	Dimensions of Assembly (mm)			Dimensions of Block (mm)														
	H	H ₁	N	W	B	B ₁	C	L ₁	L	K ₁	K ₂	G	M	T	T ₁	T ₂	H ₂	H ₃
GHW15CB	24	4.4	16	47	38	4.5	30	39.5	59.5	3.35	4.75	5.5	φ4.5	6	7	8.9	4	4
GHW20CB	30	4.3	21.5	63	53	5	40	50.5	74.5	5	6	12	φ6	8	9.5	10	6	6
GHW20HB								65.2	89.2									
GHW25CB	36	5.6	23.5	70	57	6.5	45	58	82	5	6	12	φ7	8	10	14	6	5.5
GHW25HB								78.6	102.6									
GHW30CB	42	5.5	31	90	72	9	52	70	96	6.5	5.5	12	φ9	8.5	10	16	7	6
GHW30HB								93	119									
GHW35CB	48	7.4	33	100	82	9	62	80	110.6	5.5	6.5	12	φ9	10	13	18	9	8
GHW35HB								105.8	136.4									
GHW45CB	60	9.5	37.5	120	100	10	80	97	135.4	4.8	8	13	φ11	15	15	22	11	10
GHW45HB								128.8	167.2									
GHW55CB	70	13	43.5	140	116	12	95	117.7	161.9	6	11	13	φ14	17.5	17	26.5	12	19
GHW55HB								155.8	200									
GHW65CB	90	15	53.5	170	142	14	110	144.2	194.2	6	14	13	φ16	25	23	37.5	15	15
GHW65HB								203.6	253.6									

Note : 1kgf = 9.81N

Model No.	Dimensions of Rail(mm)							Mounting Bolt for Rail (mm)	Basic Dynamic load Rating C (KN)	Basic Static load Rating C ₀ (KN)	Static Rated Moment			Weight	
	W _R	H _R	D	h	d	P	E				M _R KN-m	M _P KN-m	M _V KN-m	Block kg	Rail kg/m
GH15	15	15	7.5	5.3	4.5	60	20	M4×16	14.26	22.88	0.12	0.10	0.10	0.18	1.42
GH20	20	17.5	9.5	8.5	6	60	20	M5×16	26.29	35.76	0.26	0.20	0.20	0.41	2.2
									31.72	46.76	0.34	0.34	0.34	0.52	
GH25	23	22	11	9	7	60	20	M6×20	33.85	51.5	0.41	0.32	0.32	0.58	3.25
									40.93	67.34	0.55	0.56	0.56	0.78	
GH30	28	26	14	12	9	80	20	M8×25	47.77	70.79	0.65	0.52	0.52	1.05	4.49
									57.72	92.58	0.86	0.9	0.9	1.4	
GH35	34	29	14	12	9	80	20	M8×25	63.63	92.47	1.14	0.79	0.79	1.55	6.36
									76.73	120.93	1.51	1.37	1.37	2.06	
GH45	45	38	20	17	14	105	22.5	M12×35	102.24	144.51	1.94	1.52	1.52	2.73	10.45
									123.42	188.97	2.58	2.63	2.63	3.65	
GH55	53	44	23	20	16	120	30	M14×45	150.14	207.01	3.62	2.59	2.59	4.5	15.12
									181.2	270.71	4.78	4.48	4.48	5.94	
GH65	63	53	26	22	18	150	35	M16×50	208.94	281.73	6.52	4.18	4.18	9.35	21.25
									272.24	411.77	9.19	7.23	7.23	13.25	

Note : 1kgf = 9.81N

GH Series - Heavy Duty Ball Linear Guide

(5) GHW-CC / GHW-HC

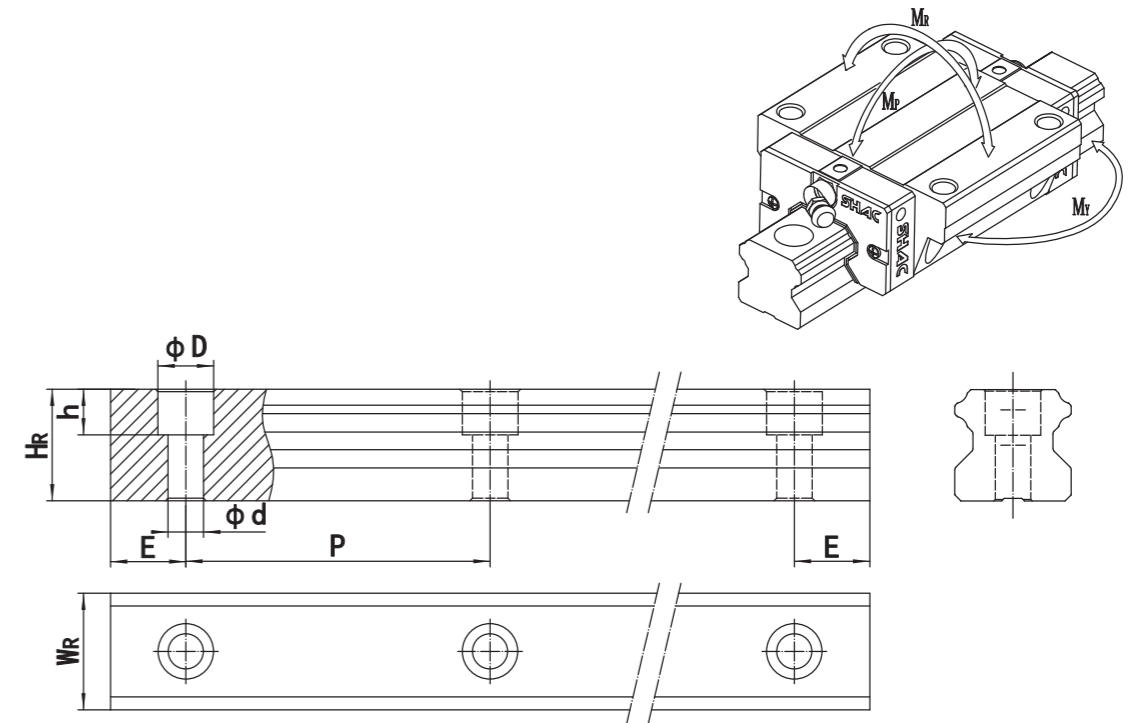
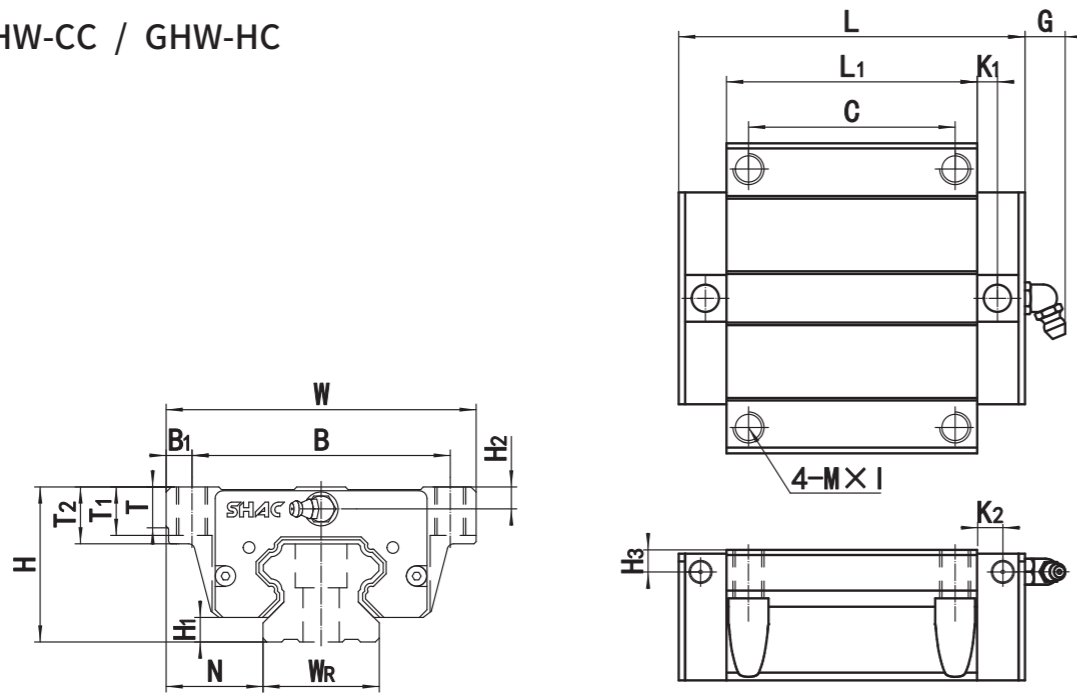

Model No.	Dimensions of Assembly (mm)			Dimensions of Block (mm)														
	H	H ₁	N	W	B	B ₁	C	L ₁	L	K ₁	K ₂	G	M	T	T ₁	T ₂	H ₂	H ₃
GHW15CC	24	4.4	16	47	38	4.5	30	39.5	59.5	3.35	4.75	5	M5	6	7	8.9	4	4
GHW20CC	30	4.3	21.5	63	53	5	40	50.5	74.5	5	6	12	M6	8	9.5	10	6	6
GHW20HC								65.2	89.2									
GHW25CC	36	5.6	23.5	70	57	6.5	45	58	82	5	6	12	M8	8	10	14	6	5.5
GHW25HC								78.6	102.6									
GHW30CC	42	5.5	31	90	72	9	52	70	96	6.5	5.5	12	M10	8.5	10	16	7	6
GHW30HC								93	119									
GHW35CC	48	7.4	33	100	82	9	62	80	110.6	5.5	6.5	12	M10	10	13	18	9	8
GHW35HC								105.8	136.4									
GHW45CC	60	9.5	37.5	120	100	10	80	97	135.4	4.8	8	13	M12	15	15	22	11	10
GHW45HC								128.8	167.2									
GHW55CC	70	13	43.5	140	116	12	95	117.7	161.9	6	11	13	M14	17.5	17	26.5	12	19
GHW55HC								155.8	200									
GHW65CC	90	15	53.5	170	142	14	110	144.2	194.2	6	14	13	M16	25	23	37.5	15	15
GHW65HC								203.6	253.6									

Note : 1kgf = 9.81N

Model No.	Dimensions of Rail(mm)							Mounting Bolt for Rail (mm)	Basic Dynamic load Rating C (KN)	Basic Static load Rating C0 (KN)	Static Rated Moment			Weight	
	W _R	H _R	D	h	d	P	E				M _R KN—m	M _P KN—m	M _V KN—m	Block kg	Rail kg/m
GH15	15	15	7.5	5.3	4.5	60	20	M4×16	14.26	22.88	0.12	0.10	0.10	0.18	1.42
GH20	20	17.5	9.5	8.5	6	60	20	M5×16	26.29	35.76	0.26	0.20	0.20	0.41	2.2
									31.72	46.76	0.34	0.34	0.34	0.52	
GH25	23	22	11	9	7	60	20	M6×20	33.85	51.5	0.41	0.32	0.32	0.58	3.25
									40.93	67.34	0.55	0.56	0.56	0.78	
GH30	28	26	14	12	9	80	20	M8×25	47.77	70.79	0.65	0.52	0.52	1.05	4.49
									57.72	92.58	0.86	0.9	0.9	1.4	
GH35	34	29	14	12	9	80	20	M8×25	63.63	92.47	1.14	0.79	0.79	1.55	6.36
									76.73	120.93	1.51	1.37	1.37	2.06	
GH45	45	38	20	17	14	105	22.5	M12×35	102.24	144.51	1.94	1.52	1.52	2.73	10.45
									123.42	188.97	2.58	2.63	2.63	3.65	
GH55	53	44	23	20	16	120	30	M14×45	150.14	207.01	3.62	2.59	2.59	4.5	15.12
									181.2	270.71	4.78	4.48	4.48	5.94	
GH65	63	53	26	22	18	150	35	M16×50	208.94	281.73	6.52	4.18	4.18	9.35	21.25
									272.24	411.77	9.19	7.23	7.23	13.25	

Note : 1kgf = 9.81N

LH Series - Heavy duty ball type (injection structure type)

(6) LHH-CA / LHH-HA

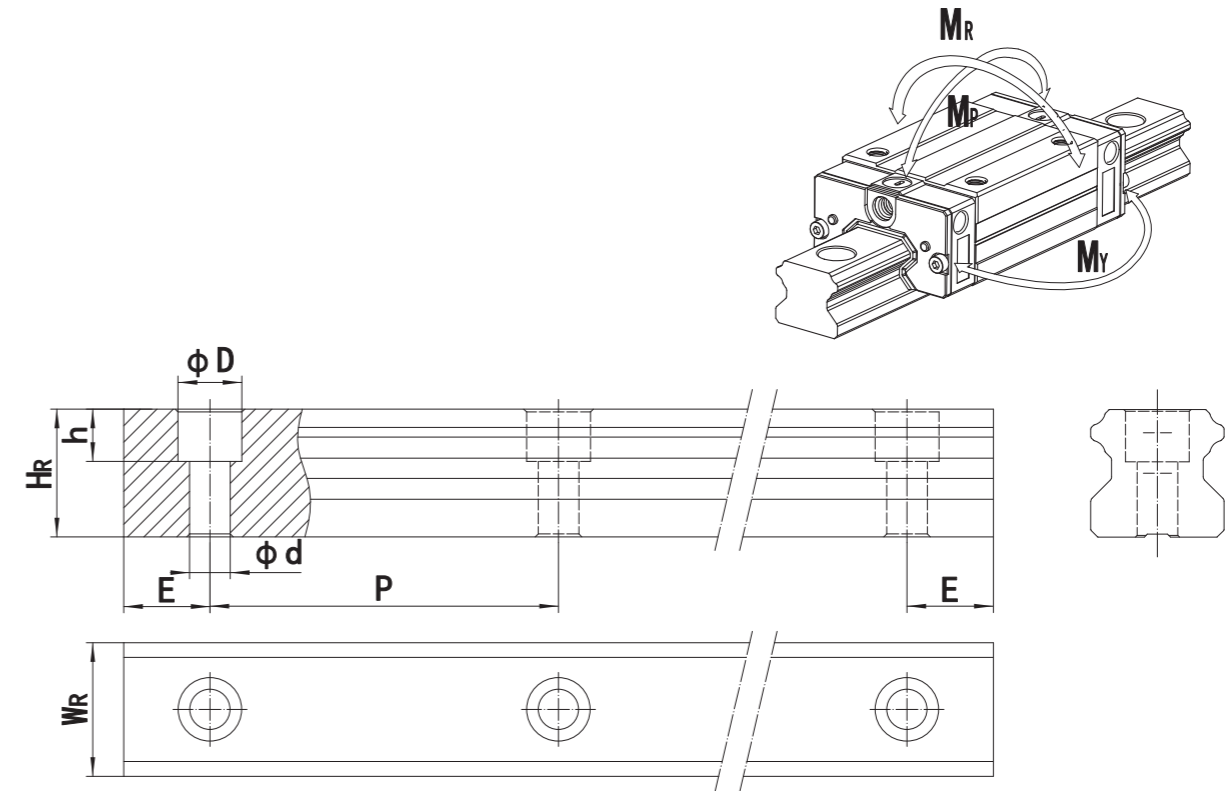
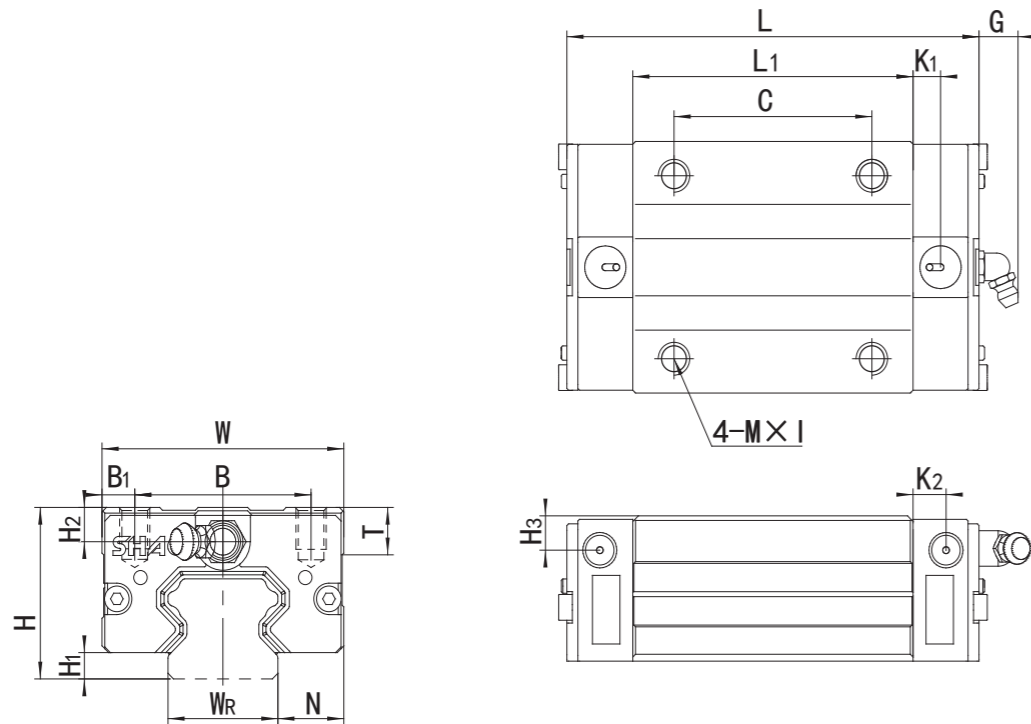

Model No.	Dimensions of Assembly (mm)			Dimensions of Block (mm)												
	H	H ₁	N	W	B	B ₁	C	L ₁	L	K ₁	K ₂	G	M*I	T	H ₂	H ₃
LHH15CA	28	4.3	9.5	34	26	4	26	40	60	3.5	4	7	M4×5	6	8	7.7
LHH20CA	30	4.6	12	44	32	6	36	51	75	5	6	12	M5×6	8	6	6
LHH20HA							50	65.2	89.2							
LHH25CA	40	6.5	12.5	48	35	6.5	35	60	84.4	4.5	5.5	12	M6×8	8	10	9.5
LHH25HA							50	81.5	105.9							
LHH30CA	45	7	16	60	40	10	40	71.5	97.5	5.5	6	12	M8×10	8.5	9.5	9.5
LHH30HA							60	94	120							

Note : 1kgf = 9.81N

Model No.	Dimensions of Rail(mm)							Mounting Boit for Rail (mm)	Basic Dynamic load Rating (KN)	Basic Static load Rating (KN)	Static Rated Monent			Weight	
	W _r	H _r	D	h	d	P	E				C ₀ (KN)	M _r KN-m	M _p KN-m	M _v KN-m	Block kg
LH15	15	15	7.5	5.3	4.5	60	20	M4×16	16.40	22.88	0.12	0.10	0.10	0.22	1.42
LH20	20	17.5	9.5	8.5	6	60	20	M5×16	30.23	35.76	0.26	0.20	0.20	0.37	2.2
									36.48	46.76	0.34	0.34	0.34	0.50	
LH25	23	22	11	9	7	60	20	M6×20	38.93	51.5	0.41	0.32	0.32	0.62	3.25
									47.07	67.34	0.55	0.56	0.56	0.81	
LH30	28	26	14	12	9	80	20	M8×25	54.94	70.79	0.65	0.52	0.52	1.03	4.49
									66.38	92.58	0.86	0.9	0.9	1.40	

Note : 1kgf = 9.81N

LH Series - Heavy duty ball type (injection structure type)

(7) LHW-CC / LHW-HC

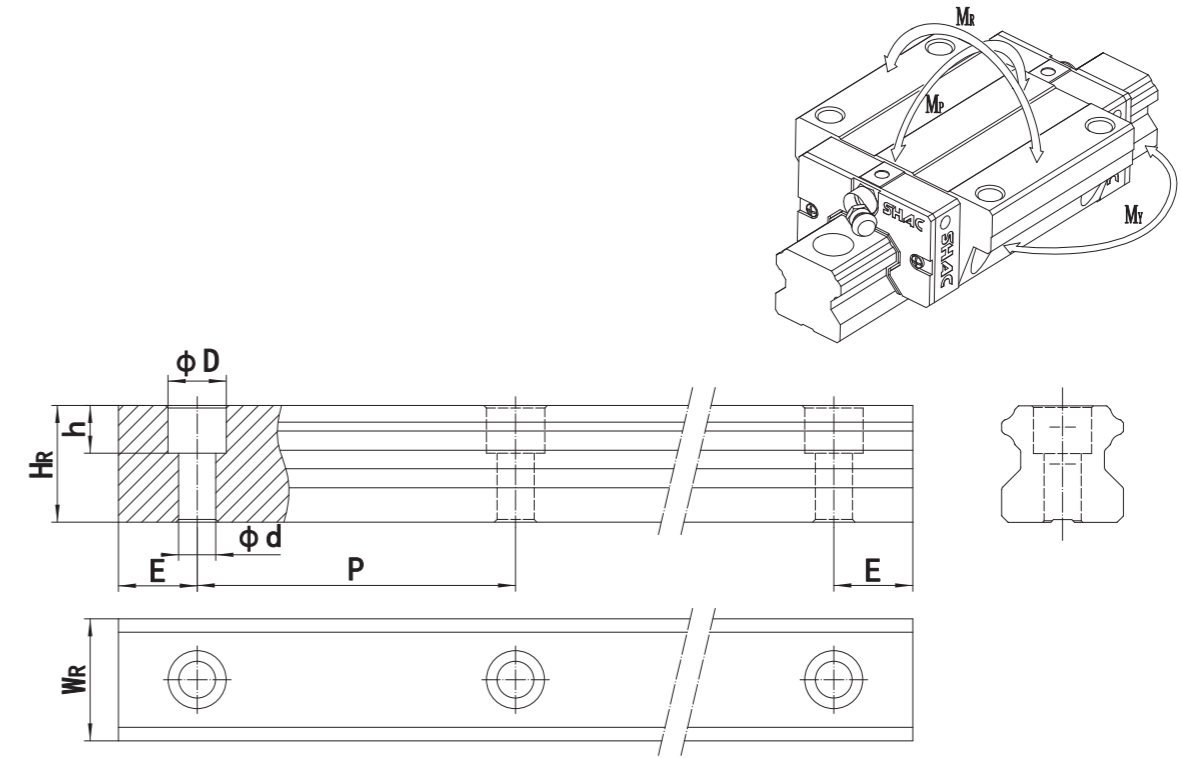
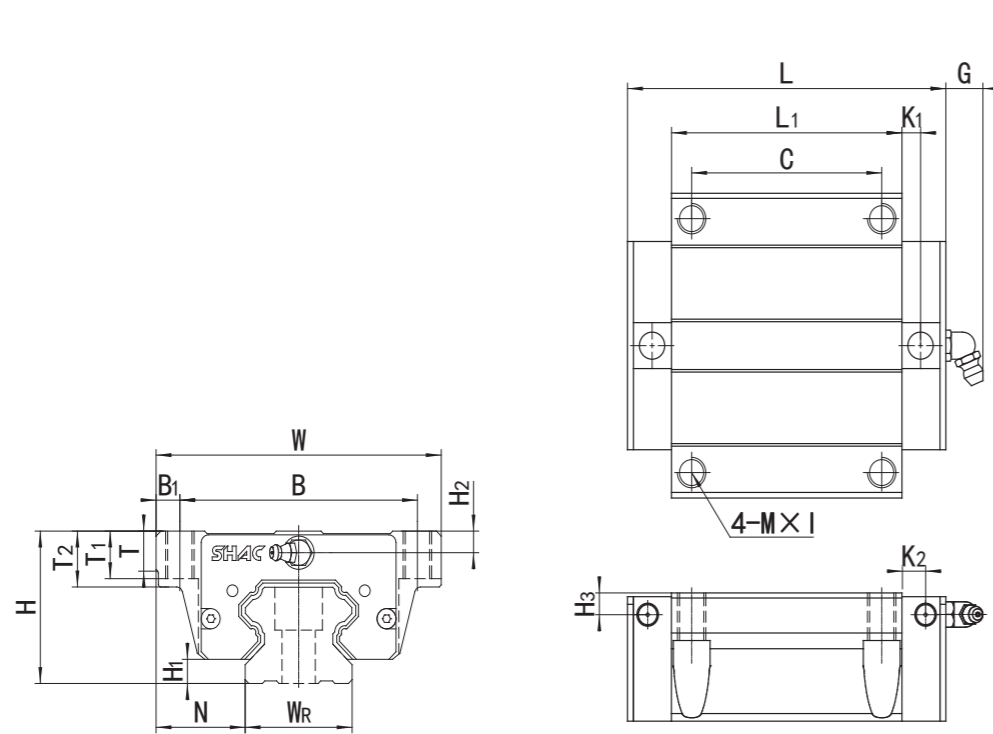

Model No.	Dimensions of Assembly (mm)			Dimensions of Block (mm)														
	H	H ₁	N	W	B	B ₁	C	L ₁	L	K ₁	K ₂	G	M	T	T ₁	T ₂	H ₂	H ₃
LHW15CC	24	4.3	16	47	38	4.5	30	40	60	3.5	4	5	M5	6	7	8.9	4	3.7
LHW20CC	30	4.6	21.5	63	53	5	40	51	75	5	6	12	M6	8	9.5	10	6	6
LHW20HC								65.2	89.2									
LHW25CC	36	6.5	23.5	70	57	6.5	45	60	84.4	4.5	5.5	12	M8	8	10	14	6	5.5
LHW25HC								81.5	105.9									
LHW30CC	42	7	31	90	72	9	52	71.5	97.5	5.5	6	12	M10	8.5	10	16	6.5	6.5
LHW30HC								94	120									

Note : 1kgf = 9.81N

Model No.	Dimensions of Rail(mm)							Mounting Bolt for Rail (mm)	Basic Dynamic load Rating C (KN)	Basic Static load Rating C0 (KN)	Static Rated Moment			Weight	
	W _R	H _R	D	h	d	P	E				M _R KN-m	M _P KN-m	M _V KN-m	Block kg	Rail kg/m
LH15	15	15	7.5	5.3	4.5	60	20	M4×16	16.40	22.88	0.12	0.10	0.10	0.21	1.42
LH20	20	17.5	9.5	8.5	6	60	20	M5×16	30.23	35.76	0.26	0.20	0.20	0.45	2.2
									36.48	46.76	0.34	0.34	0.34	0.57	
LH25	23	22	11	9	7	60	20	M6×20	38.93	51.5	0.41	0.32	0.32	0.62	3.25
									47.07	67.34	0.55	0.56	0.56	0.82	
LH30	28	26	14	12	9	80	20	M8×25	54.94	70.79	0.65	0.52	0.52	1.10	4.49
									66.38	92.58	0.86	0.9	0.9	1.52	

Note : 1kgf = 9.81N

Heavy duty ball type (rail with protective cover strip)

(8) GHH-CA-S / GHH-HA-S

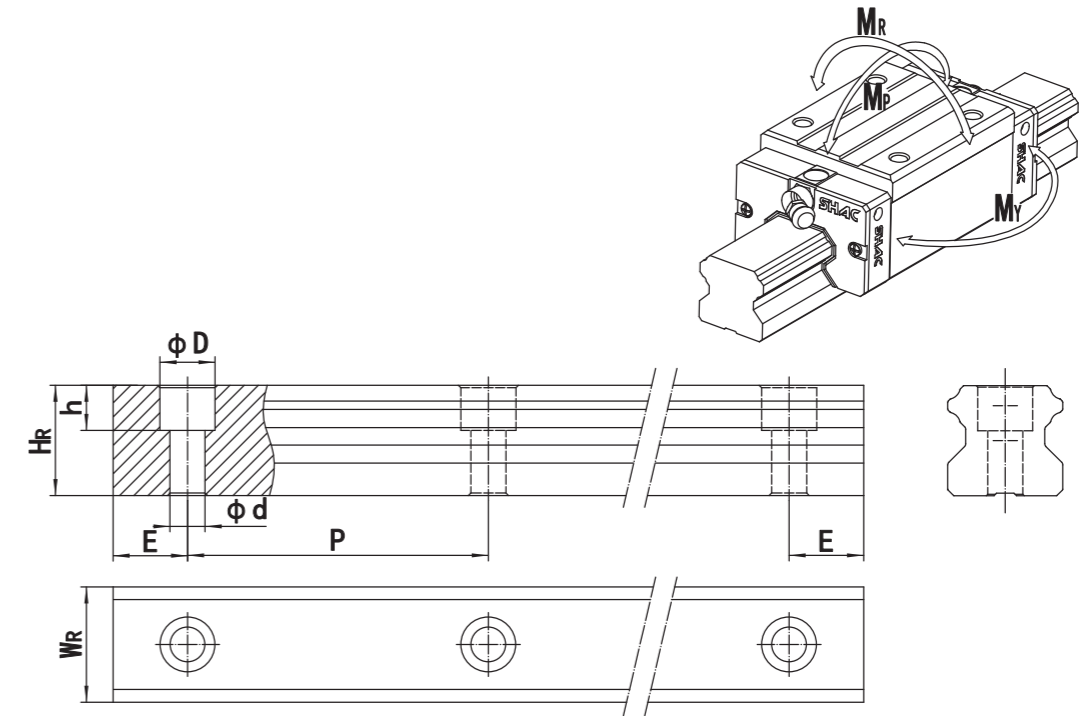
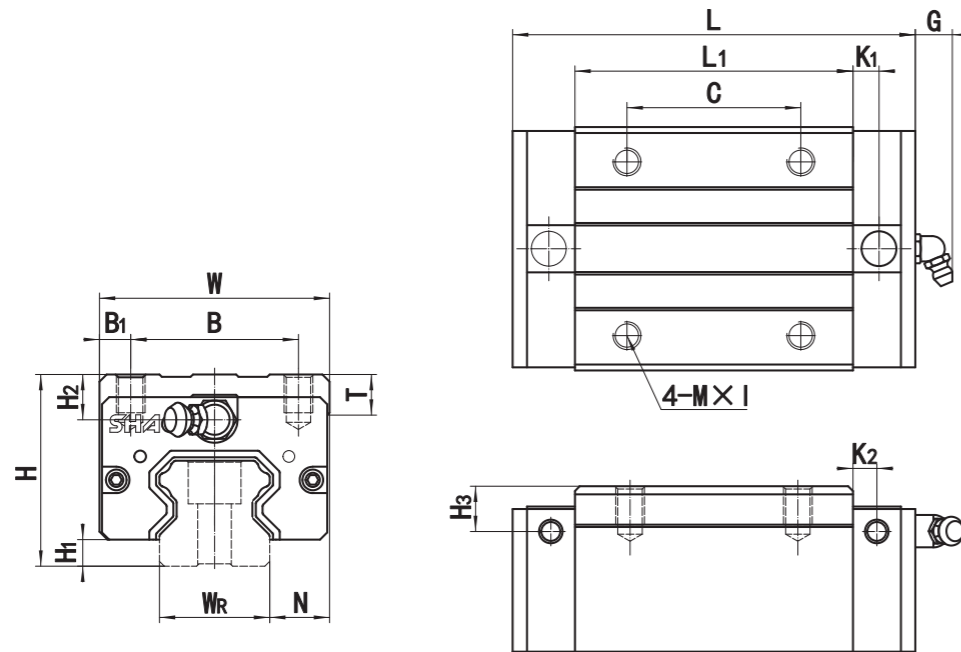

Model No.	Dimensions of Assembly (mm)			Dimensions of Block (mm)													
	H	H ₁	N	W	B	B ₁	C	L ₁	L	K ₁	K ₂	G	M*I	T	H ₂	H ₃	
GHH20CA-S	30	4.3	12	44	32	6	36	50.5	76.5	5	6	12	M5×6	8	6	6	
GHH20HA-S							50	65.2	91.2								
GHH25CA-S	40	5.6	12.5	48	35	6.5	35	58	82	5	6	12	M6×8	8	10	9.5	
GHH25HA-S							50	78.6	102.6								
GHH30CA-S	45	5.5	16	60	40	10	40	70	98	6.5	5.5	12	M8×10	8.5	10	9	
GHH30HA-S							60	93	121								

Note : 1kgf = 9.81N

Model No.	Dimensions of Rail(mm)								Mounting Boit for Rail (mm)	Basic Dynamic load Rating C (KN)	Basic Static load Rating C0 (KN)	Static Rated Monent			Weight	
	W _R	H _R	D	h	d	P	E	M _R KN-m				M _P KN-m	M _V KN-m	Block kg	Rail kg/m	
GH20-S	20	19.3	9.5	8.5	6	60	20	M5×16	17.2	25.6	0.25	0.18	0.18	0.33	2.2	
									20.8	33.55	0.32	0.31	0.31	0.41		
GH25-S	23	23.3	11	9	7	60	20	M6×20	25.11	36.42	0.41	0.32	0.32	0.53	3.25	
									30.73	48.56	0.55	0.56	0.56	0.71		
GH30-S	28	27.8	14	12	9	80	20	M8×25	34.93	49.58	0.58	0.5	0.5	0.92	4.49	
									42.72	66.1	0.8	0.9	0.9	1.20		

Note : 1kgf = 9.81N

Heavy duty ball type (rail with protective cover strip)

(9) GHW-CC-S / GHW-HC-S

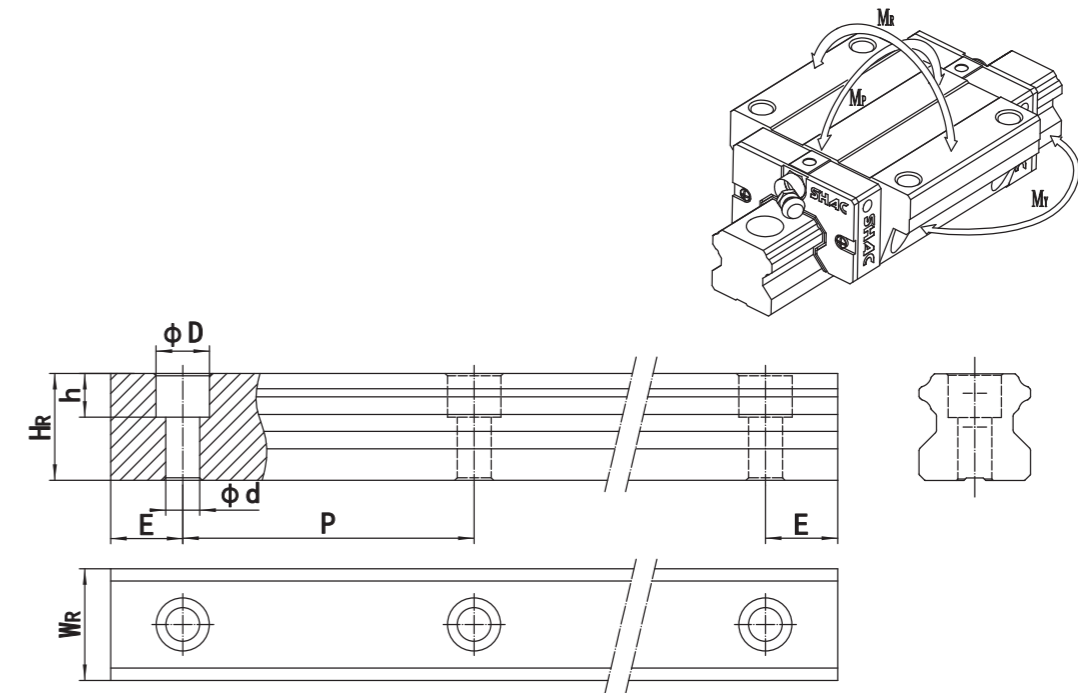
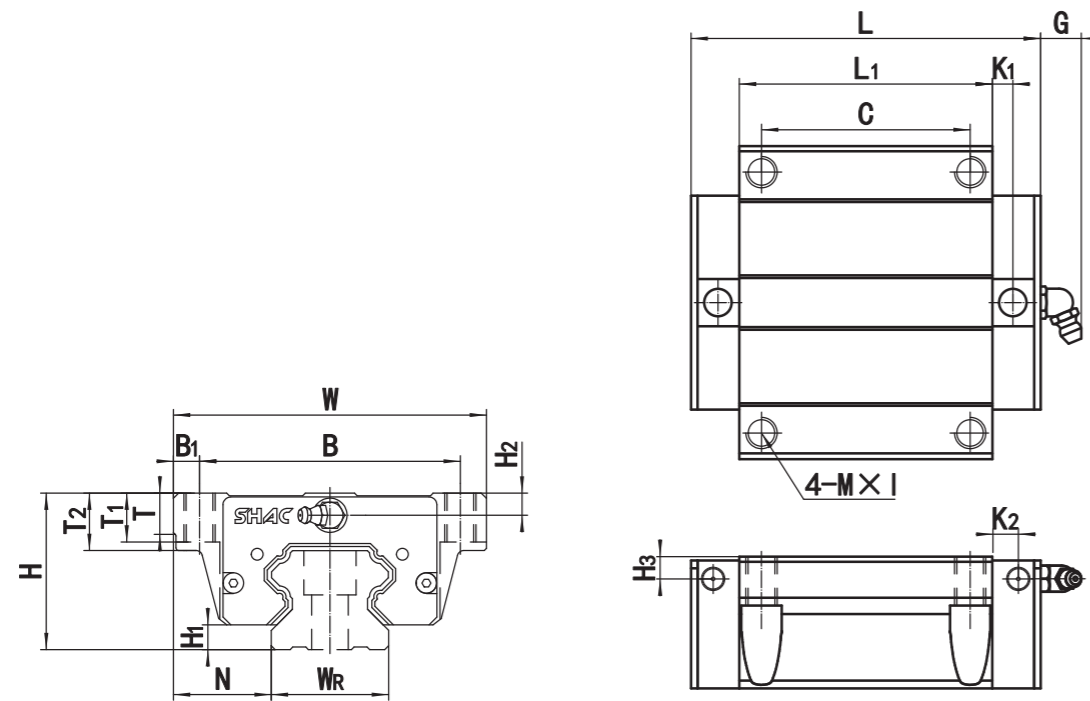

Model No.	Dimensions of Assembly (mm)			Dimensions of Block (mm)														
	H	H ₁	N	W	B	B ₁	C	L ₁	L	K ₁	K ₂	G	M	T	T ₁	T ₂	H ₂	H ₃
GHW20CC-S	30	4.3	21.5	63	53	5	40	50.5	74.5	5	6	12	M6	8	9.5	10	6	6
GHW20HC-S								65.2	89.2									
GHW25CC-S	36	5.6	23.5	70	57	6.5	45	58	82	5	6	12	M8	8	10	14	10	9.5
GHW25HC-S								78.6	102.6									
GHW30CC-S	42	5.5	31	90	72	9	52	70	96	6.5	5.5	12	M10	8.5	10	16	10	9
GHW30HC-S								93	119									

Note : 1kgf = 9.81N

Model No.	Dimensions of Rail(mm)							Mounting Bolt for Rail (mm)	Basic Dynamic load Rating C (KN)	Basic Static load Rating C0 (KN)	Static Rated Moment			Weight	
	W _R	H _R	D	h	d	P	E				M _R KN-m	M _P KN-m	M _V KN-m	Block kg	Rail kg/m
GH20-S	20	19.3	9.5	8.5	6	60	20	M5×16	26.29	35.76	0.26	0.2	0.2	0.41	2.2
									31.72	46.76	0.34	0.34	0.34	0.52	
GH25-S	23	23.3	11	9	7	60	20	M6×20	33.85	51.5	0.41	0.32	0.32	0.58	3.25
									40.93	67.34	0.55	0.56	0.56	0.78	
GH30-S	28	27.8	14	12	9	80	20	M8×25	47.77	70.79	0.65	0.52	0.52	1.05	4.49
									57.72	92.58	0.86	0.9	0.9	1.4	

Note : 1kgf = 9.81N

GH Series - Heavy Duty Ball Linear Guide

GHR-T Dimensions of Guide Rail Mounting form bottom

(10) GHR-T

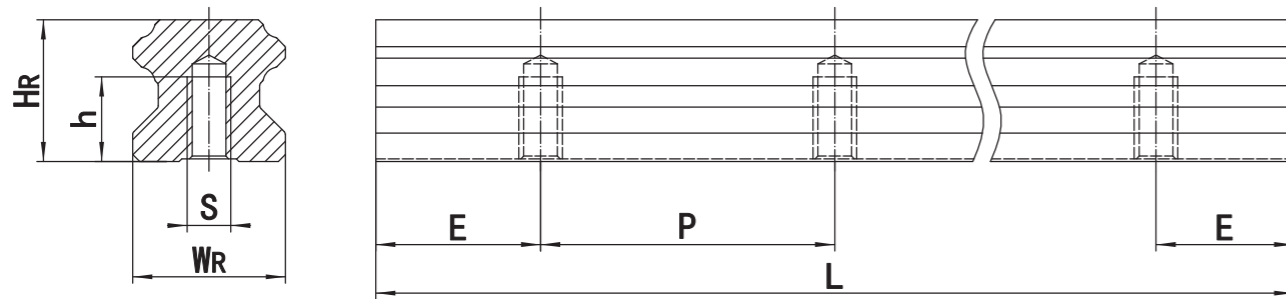

Model No.	Dimensions of Block (mm)					Weight (kg/m)
	W _R	H _R	S	h	P	
GHR15T	15	15	M5×0.8P	8	60	1.45
GHR20T	20	17.5	M6×1P	10	60	2.27
GHR25T	23	22	M6×1P	12	60	3.34
GHR30T	28	26	M8×1.25P	15	80	4.65
GHR35T	34	29	M8×1.25P	17	80	6.5
GHR45T	45	38	M12×1.75P	24	105	10.9
GHR55T	53	44	M14×2P	24	120	15.65
GHR65T	63	53	M20×2.5P	30	150	21.7

Note : 1kgf = 9.81N

2-3 GE Series - Low Assembly Ball Linear Guide

Product characteristics

GE series linear guide rail adopts four rows of arc groove 45° contact angle. The optimized structural design can achieve the load energy in four directions. The force is the same, regardless of the various installation methods of X, Y, Z axis, etc. Use of. It has high load capacity and dynamic regulation functions, The product rigidity can be further improved by improving the assembly preload. Not suitable for high precision and high load product demands.

GE series has lower assembly height and shorter

Slide length is often advantageous for small equipment with limited installation space.

Product Structure

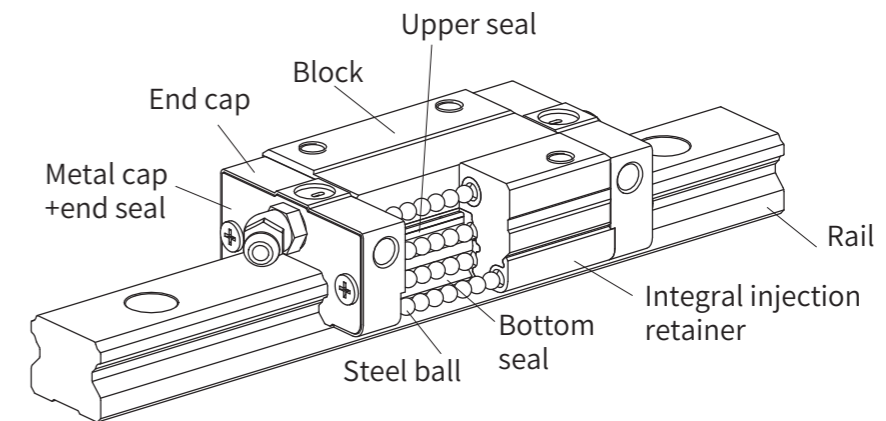

Figure 2-2-1 LEH20CA

- ◎Rolling circulation system: slider, guide rail, end cover, steel ball, steel ball retainer
- ◎Lubricating system: nozzle, oil pipe joint
- ◎Dust prevention system: dust strip, bottom dust seal dust strip, guide rail cap, metal

Recommended Applicable Equipment :

Precision space limitation: automation industry, electronic semiconductor, laser processing, 3D printing, etc.

Table 2-2-1

Item	Product advantages	Corresponding efficiency
1	Four row rigid	Four-row ball groove provides four-direction load capacity, improving rigidity by increasing preload
2	DF self centering	45Degree ball path contact angle with automatic strip centering for longer life and accuracy
3	Interchangeability performance	The advanced manufacturing technology and strict quality control make the dimensional tolerance of the same model stable and interchangeable
4	Pre-pressure fitting	Optional level 4 standard preload for further accuracy and rigidity
5	Dust proof accessory	Standard dust proof configuration and optional DD, KK, ZZ dust proof kit for environmental adaptability
6	Lubrication Options	Fitted with eight mounting positions, multiple nipples provide clear oil capacity and recommended oil feed rates
7	Low assembly series	Compared with GH standard size, it has high precision and high strength application environment, which can reduce the center of gravity of equipment and is applicable to supporting

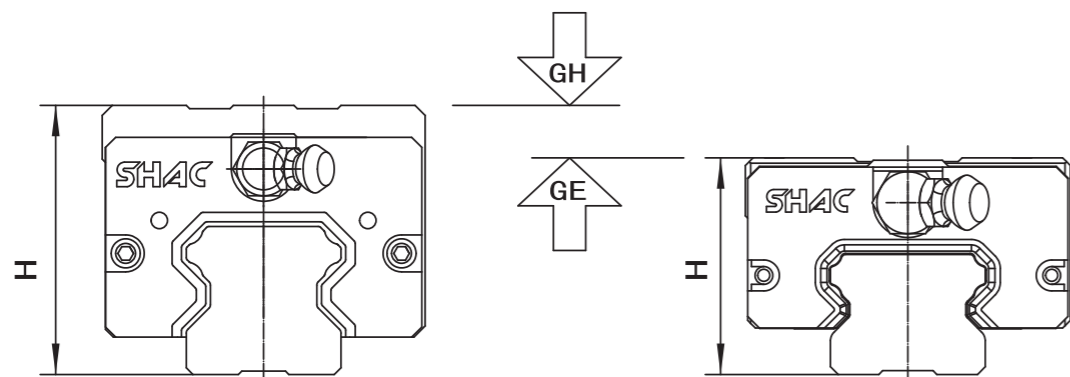
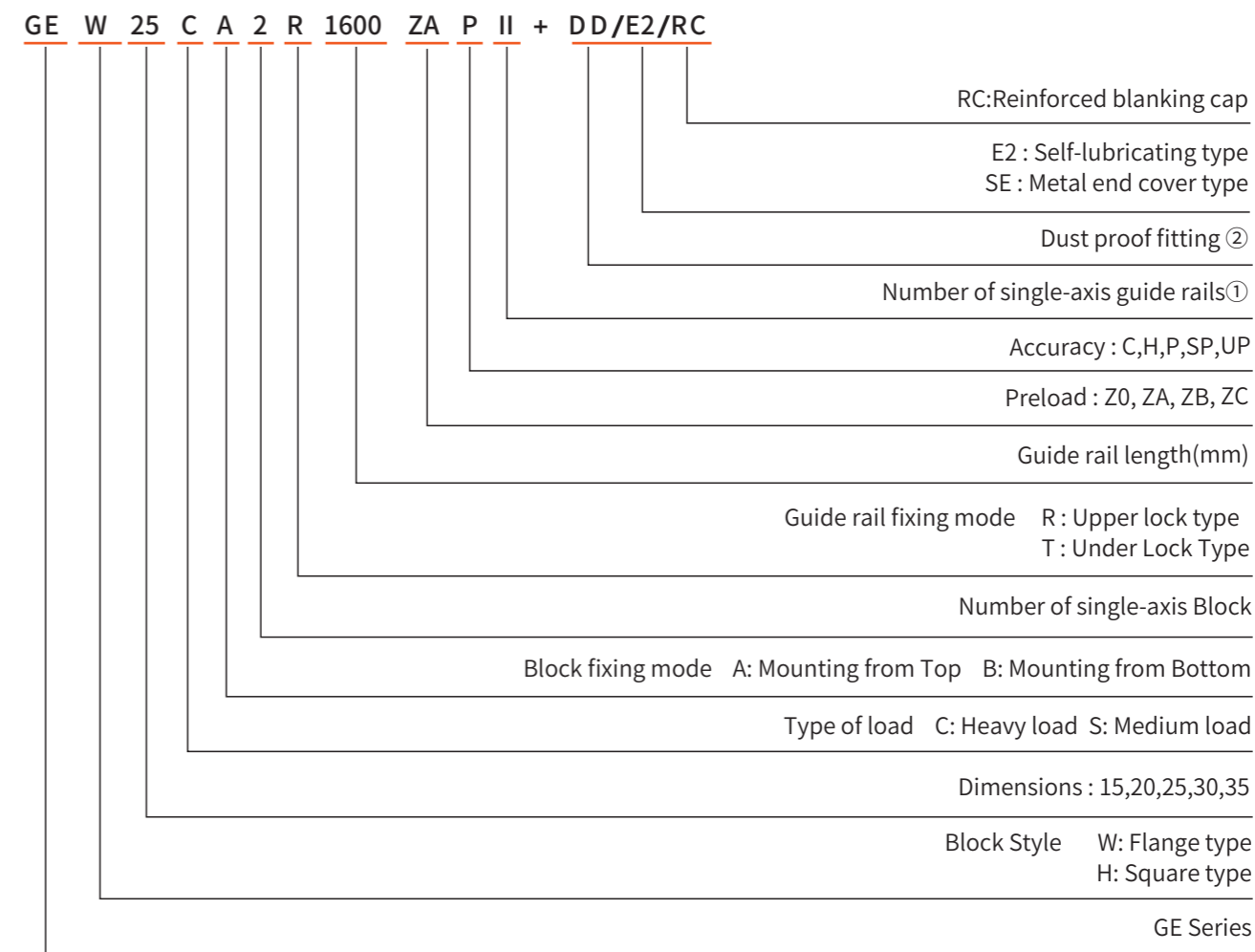

Figure 2-2-2

2-3-1 Product model of non-interchangeable linear guide rail



Note:

- The number of single-axis guide rails shall not be written if only — support guide rails are used. Two guide rails are marked as II, three guide rails are marked as III, and so on.
- The dust proof accessories with several weights are standard dust proof accessories with dust strip.
 ZZ: dust strip, dust strip and metal scraper.
 KK is double dust proof, dust strip and metal scraper.
 DD DUAL DUAL DUST FINS WITH DUST STRIPS.
 The sliding block type L is the low assembled sliding block of square type H, and the combined height is consistent with the flange type of the same size.

2-3-2 Product model of interchangeable linear guide rail

Product model of interchangeable sliding block

GE	W	25	C	A	ZA	P	+	ZZ/E2
								E2: Self-lubricating type SE: Metal end cover type
								Dust proof fitting②
								Accuracy: C,H,P,SP,UP
								Preload: Z0, ZA, ZB, ZC
								Block fixing mode A: Mounting from Top B: Mounting from Bottom
								Type of load C: Heavy load S: Medium load
								Dimensions: 15,20,25,30,35
								Block Style W: Flange type H: Square type
GE Series								

Product model of interchangeable guide rail

GE	R	25	R	1200	P	+	RC	
								RC: Reinforced blanking cap
								Accuracy: C,H,P
								Guide rail length(mm)
								Rail fixing mode R: Mounting from Top T: Mounting from Bottom
								Dimensions: 15,20,25,30,35
								Single output guide rail
GE Series								

2-3-3 GE Series - Low Assembly Ball Linear Guide

(1) block type

SHAC provides two types of linear guide rails, i.e. flanged guide rail and square guide rail. The overall combination height of flanged guide rail is lower and the width is wider. The flange part is provided with machined through screw holes, which can meet the installation requirements of lower lock type

Table 2-2-2 Type Block Type

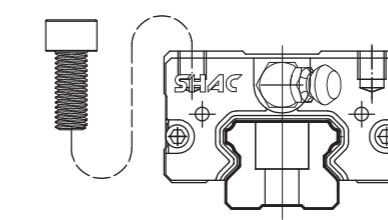
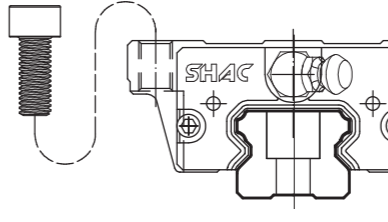
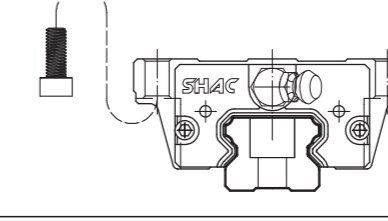
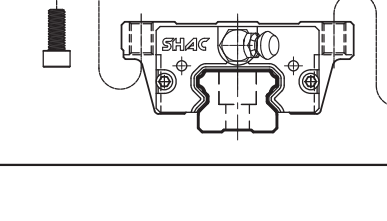
Style	Specification	SHAPE	Height dimension	Guide rail length	Equipment suitable for application
Square	GEH-SA GEH-CA		24	100	<ul style="list-style-type: none"> Precision measuring instrument. Automation device.
			48	6000	
Flange	GEW-SA GEW-CA		24	100	<ul style="list-style-type: none"> High-speed transportation equipment. Semiconductor equipment
			48	6000	
	GEW-SB GEW-CB		24	100	
			48	6000	
GEW-SC GEW-CC		24	100		
		48	6000		

(2) Guideways

In addition to the general locking screw hole guide rail, the lower locking screw hole guide rail is also provided for the convenience of customer installation and use.

Mounting from Top

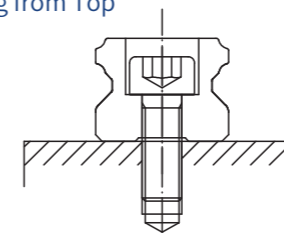

Mounting from Bottom

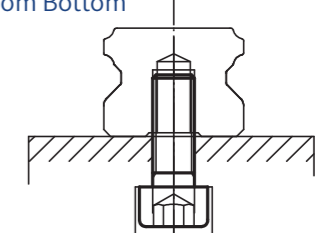

Figure 2-2-3

Grade of accuracy

The precision of GE series linear guide rail can be divided into five levels: ordinary level, advanced level, precision level, ultra-precision level and ultra-high precision level. Users can select products of corresponding level according to equipment requirements

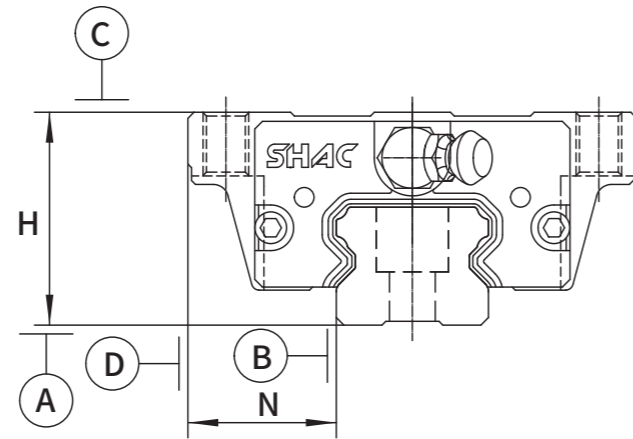

Figure 2-2-4

2-3-4 Precision of non-interchangeable linear guide rail

Table 2-2-3 Assembly accuracy table

Unit : mm

Model No.	GE-15, 20				
Grade of accuracy	Ultra-Precision Level (UP)	Super-Precision Level (SP)	Precision Level (P)	High Level (H)	Ordinary Level (C)
Allowable dimension error of height H	0 -0.008	0 -0.015	0 -0.03	±0.03	±0.1
Allowable error of width N	0 -0.008	0 -0.015	0 -0.03	±0.03	±0.1
Mutual error of paired width H	0.003	0.004	0.006	0.01	0.02
Allowable error of paired width N	0.003	0.004	0.006	0.01	0.02
Traveling parallelism of slide block C to surface A of guide rail	Travel Parallelism (see Table 2-2-7)				
Traveling parallelism of slide block D to surface B of guide rail					

Table 2-2-4 Assembly accuracy table

Unit : mm

Model No.	GE-25, 30, 35				
Grade of accuracy	Ultra-Precision Level (UP)	Super-Precision Level (SP)	Precision Level (P)	High Level (H)	Ordinary Level (C)
Allowable dimension error of height H	0 -0.01	0 -0.02	0 -0.04	±0.04	±0.1
Allowable error of width N	0 -0.01	0 -0.02	0 -0.04	±0.04	±0.1
Mutual error of paired width H	0.003	0.005	0.007	0.015	0.02
Allowable error of paired width N	0.003	0.005	0.007	0.015	0.03
Traveling parallelism of slide block C to surface A of guide rail	Travel Parallelism (see Table 2-2-7)				
Traveling parallelism of slide block D to surface B of guide rail					

2-3-5 Precision of interchangeable linear guide rail

Table 2-2-5 Single Output Accuracy Table

Unit : mm

Model No.	GE-15, 20		
Grade of accuracy	Precision Level (P)	High Level (H)	Ordinary Level (C)
Allowable dimension error of height H	±0.015	±0.03	±0.1
Allowable error of width N	±0.015	±0.03	±0.1
Mutual error of paired width H	0.006	0.01	0.02
Allowable error of paired width N	0.006	0.01	0.02
Traveling parallelism of slide block C to surface A of guide rail	Travel Parallelism (see Table 2-2-7)		
Traveling parallelism of slide block D to surface B of guide rail			

Table 2-2-6 Single Output Accuracy Table

Unit : mm

Model No.	GE—25, 30, 35		
Grade of accuracy	Precision Level (P)	High Level (H)	Ordinary Level (C)
Allowable dimension error of height H	±0.02	±0.04	±0.1
Allowable error of width N	±0.02	±0.04	±0.1
Mutual error of paired width H	0.007	0.015	0.02
Allowable error of paired width N	0.007	0.015	0.03
Traveling parallelism of slide block C to surface A of guide rail	Travel Parallelism (see Table 2-2-7)		
Traveling parallelism of slide block D to surface B of guide rail			

2-3-6 Traveling parallel precision

Table 2-2-7

Linght of Rail (mm)	Gread of Precision (μm)				
	UP	SP	P	H	C
~100	2	2	3	7	12
100~200	2	2	4	9	14
200~300	2	3	5	10	15
300~500	2	3	6	12	17
500~700	2	4	7	13	20
700~900	3	5	8	15	22
900~1100	3	6	9	16	24
1100~1500	4	7	11	18	26
1500~1900	4	8	13	20	28
1900~2500	5	10	15	22	31
2500~3100	6	11	18	25	33
3100~3600	7	14	20	27	36
3600~4000	7	15	21	28	37

Preload

The so-called preloading is to increase the diameter of the steel ball to produce negative pressure between the steel ball and the channel

Clearances, pre-applied loads internally. Clearance is not only eliminated by assembly with preload it can also improve the rigidity and precision of the sliding block.

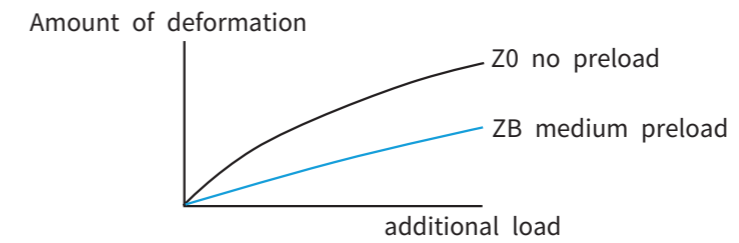

Figure 2-2-5

2-3-7 Grade of Preload

Table 2-2-8 Grade of preload

Degree of preload	Code	Preload	Service conditions
No preload	Z0	0~0.02C	Fixed load direction, small impact and low precision requirements
Light preload	ZA	0.03C~0.05C	Light duty and high accuracy required
Medium preload	ZB	0.06C~0.08C	High rigidity, vibration and impact environment
Heavy preload	ZC	0.08C~0.13C	It requires higher rigidity and has a service environment with large vibration and impact
Assembly mode	Non-interchangeable track (single output)		Non-interchangeable track (single output)
Grade of preload	Z0、ZA		Z0、ZA、ZB、ZC

Note: C in the pre-pressure is the dynamic rated load

Table 2-2-9 O-Ring Specification and maximum allowable depth

Guide rail width	O-Ring Specifications		Punching Maximum Allowable Depth Tmax (mm)
	do (mm)	W (mm)	
GE15	2.5±0.15	1.5±0.15	6.9
GE20	4.5±0.15	1.5±0.15	8.4
GE25	4.5±0.15	1.5±0.15	10.4
GE30	4.5±0.15	1.5±0.15	10.4
GE35	4.5±0.15	1.5±0.15	10.8

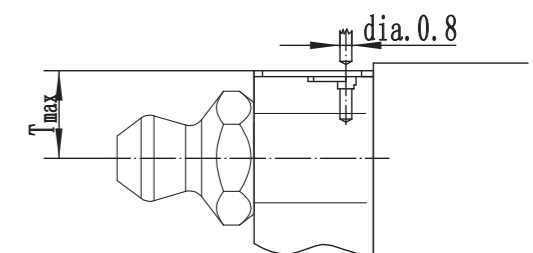

2-3-8 Lubricating oil capacity of single sliding block

Table 2-2-10 Lubricating oil capacity of single sliding block

Model No.	SA (cm ³)	CA (cm ³)
GE15	0.8	1.4
GE20	1.5	2.4
GE25	2.8	4.6
GE30	3.7	6.3
GE35	5.6	6.6

2-3-9 Lubrication frequency

Dust proof fitting

Grease shall be confirmed every 100km or every 3-6 months.

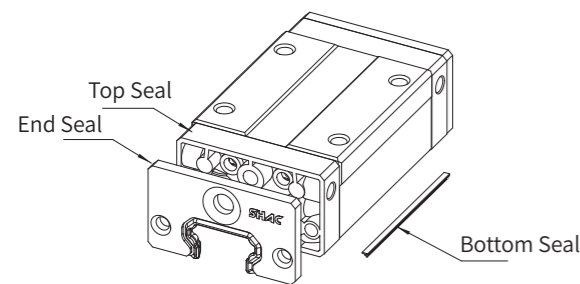

No marked as dustproof standard accessories
(End seal+Bottom Seal)

Figure 2-2-8

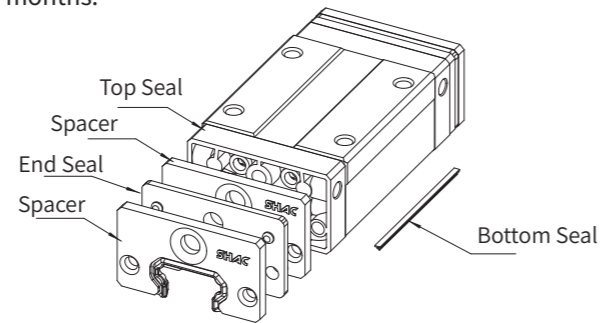

DD(Double End Seal+Bottom Seal)

Figure 2-2-9

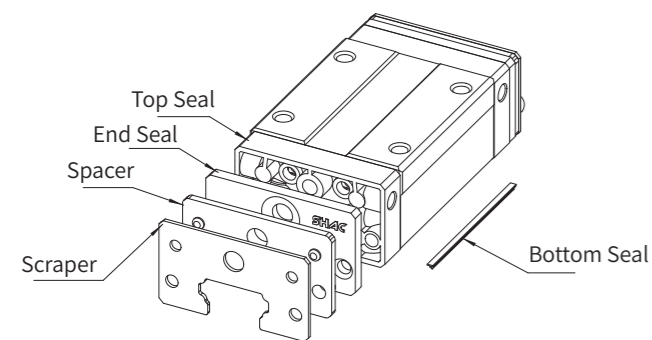

ZZ(End seal+Bottom Seal+Scraper)

Figure 2-2-10

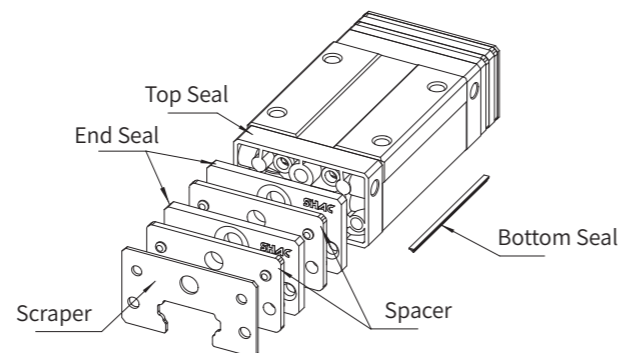

KK(Double End seal+Bottom Seal+Scraper)

Figure 2-2-11

Dust-proof fitting description

When the slider moves back and forth, scrap iron and other debris will enter the slider to damage the surface of the channel and reduce the service life of the linear guide rail. Dust, wood chips and other foreign matters will accumulate in the channel and cause blockage. Proper dust prevention measures must be taken to ensure its service life.

End seal and bottom seal

The end seal and the bottom seal can effectively prevent debris or dust from entering the inside of the slider.

Double end seal

Double dustproof effect, even in worse processing environment, it can also have excellent dust-proof effect.

Table 2-2-11 Thickness of End seal

Specification	Increase thickness (mm)
GE15	1.8
GE20	2
GE25	2
GE30	2
GE35	3

Metal scraper

Thanks to the high temperature resistance and high hardness of metal, it can effectively isolate high-temperature scrap iron and large foreign matters.

Space

Superimposed two dust sheets will affect the cooperation between guide rail and dust sheet, increase friction force, separate two dust sheets with grid piece, ensure real prepressing, reduce friction force and effectively prevent dust.

Table 2-2-12 Thickness of Scraper

Model No.	Metal scraper thickness (mm)
GE15	1.5
GE20	1.5
GE25	1.5
GE30	1.5
GE35	1.5

Table 2-2-13 Thickness of Space

Model No.	Thickness of single scraper (mm)
GE15SC	1.5
GE20SC	1.5
GE25SC	1.5
GE30SC	1.5
GE35SC	1.5

Guide rail blanking cover

Dust and foreign matters will enter the inside of the slider through the mounting hole, affecting the accuracy and service life. Use a special blanking cap to block the mounting hole so that the mounting hole plane and the guide rail plane are at the same height, which can effectively prevent foreign matters from entering the slider

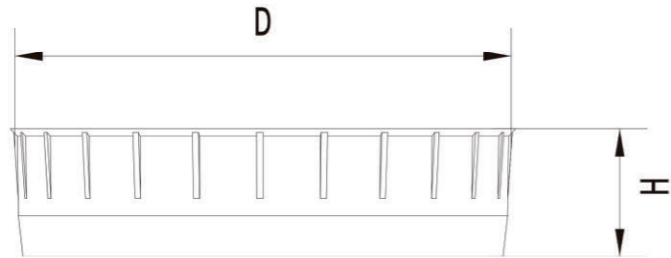

Figure 2-2-12

Table 2-2-14 Guide rail blanking cover

Guide rail specification	Screw Size	Diameter (D) (mm)	Thickness (H) (mm)
GE15R	M4	7.65	1
GE20R	M5	9.75	3.2
GE25R	M6	11.15	2.7
GE30R	M8	14.15	3.7
GE35R	M8	14.15	3.7

TOTAL SLIDE LENGTH PER DUST CODE

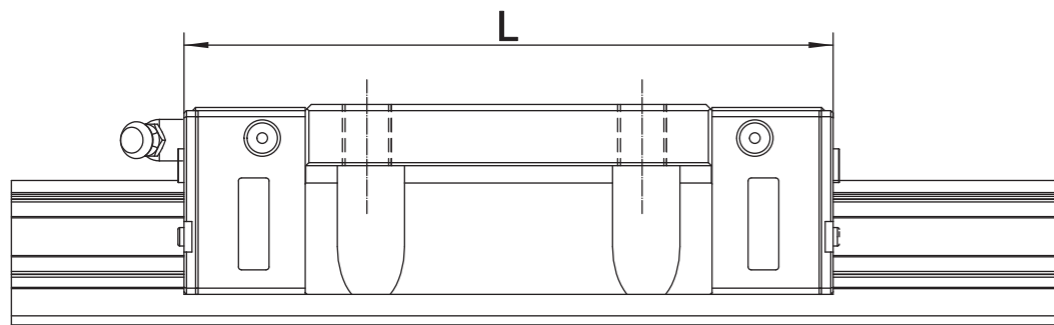

Figure 2-2-13

Table 2-2-15

L series dustproof code slider total length (mm)				
Size	Standard	ZZ	DD	KK
LE15S	-	41.1	-	46.3
LE15C	-	57.8	-	63
LE20S	-	49	-	54.2
LE20C	-	68.1	-	73.3
LE25S	-	57	-	62.2
LE25C	-	81	-	86.2

Table 2-2-16 TOTAL Block LENGTH PER DUST CODE

Specification	TOTAL Block LENGTH(L) (mm)			
	Standard	ZZ	DD	KK
GE15S	39.7	45.7	46.3	52.3
GE15C	56.4	62.4	63	69
GE20S	50.2	56.2	57.2	63.2
GE20C	69.3	75.3	76.3	82.3
GE25S	59.5	65.5	66.5	72.5
GE25C	83.1	89.1	90.1	96.1
GE30S	69.5	75.5	76.5	82.5
GE30C	98	104	105	111
GE35S	76	79	80	83
GE35C	108	111	112	115

Friction force

The resistance values in the following table are the maximum resistance of two end seal

Table 2-2-17 Resistance value of GE series dust cover

Specification	Resistance of end seal N(kgf)
GE15	1.5 (0.15)
GE20	2.55 (0.26)
GE25	3.00 (0.31)
GE30	3.9 (0.4)
GE35	4.5 (0.46)

Note : 1kgf = 9.81N

2-3-11 Allowable error of mounting surface

Due to the DF (45 ° - 45 °) combined structure of the arc groove, it has the ability of automatic centering. Even if there is a certain deviation on the installation surface, it can automatically achieve a balanced state, maintain a stable, high-precision linear motion, and greatly improve the negative service life and accuracy of the guide rail.

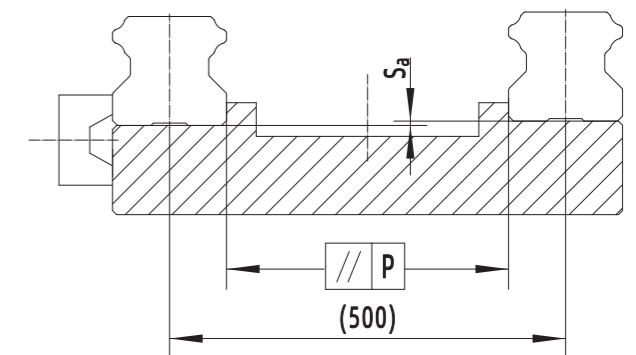

Figure 2-2-14

Table 2-2-18 Allowable parallelism error (P)

Unit: μm

Specification	Grade of preload		
	Z0	ZA	ZB
GE15	25	18	-
GE20	25	20	18
GE25	30	22	20
GE30	40	30	27
GE35	50	35	30

Table 2-2-19 Allowable upper and lower flatness error (S_a)

Unit: μm

Specification	Grade of preload		
	Z0	ZA	ZB
GE15	130	85	-
GE20	130	85	50
GE25	130	85	70
GE30	170	110	90
GE35	210	150	120

Note: The allowable value is directly proportional to the distance between two guide rails

2-3-12 Precautions for installation

(1) Precautions for installation

Height and chamfer of bearing surface

When installing the linear guide rail, pay attention to whether the size of the bearing surface is appropriate. For example, excessive chamfer will cause the guide rail and the bearing surface unable to be completely contacted,

It is easy to cause poor accuracy of linear guide rail. However, if the bearing surface is too high, it will conflict with the bottom height of the sliding block, so it cannot be installed.

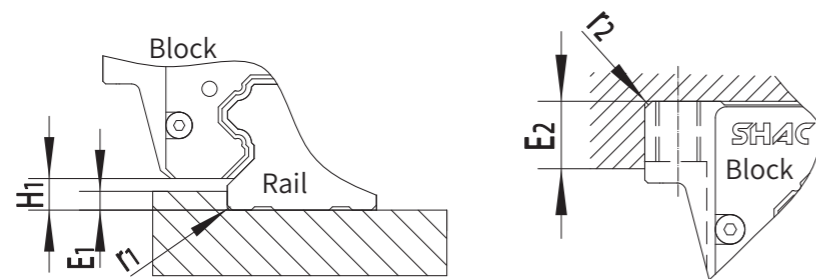

Figure 2-2-15

Table 2-2-20 Height and chamfer of bearing surface

Specification	Maximum guide rail end r_1 (mm)	Max. slide end Radius of fillet r_2 (mm)	Guide rail end bearing Height of abutting surface E_1 (mm)	Slide end bearing Height of abutting surface E_2 (mm)	Clear height of slide block H_1 (mm)	Chamfer dimensions for linear guide
						A/B
GE15	0.5	0.5	2.7	5.0	4.3	0.9
GE20	0.5	0.5	5.0	7.0	6.0	1.2
GE25	1.0	1.0	5.0	7.5	7.0	1.4
GE30	1.0	1.0	7.0	7.0	10.0	1.7
GE35	1.0	1.0	7.5	9.5	11.0	-

(2) Specification and torsion of guide rail mounting screw

The locking force of the mounting screws of the linear guide rail directly affects the service life and accuracy of the guide rail. Therefore, it is important to use a torque wrench to lock each screw with an appropriate torque value.

Table 2-2-21 Torque value

Specification	Torque value N-cm (kgf-cm)			
	Screw Size	Iron parts	Casting	Aluminium alloy
GE15	M3×0.5P×16L	186 (19)	127 (13)	98 (10)
	M4×0.7P×16L	392 (40)	274 (28)	206 (21)
GE20	M5×0.8P×16L	883 (90)	588 (60)	441 (45)
GE25	M6×1P×20L	1373 (140)	921 (94)	686 (70)
GE30	M6×1P×25L	1373 (140)	921 (94)	686 (70)
	M8×1.25P×25L	3041 (310)	2010 (206)	1470 (150)
GE35	M8×1.25P×25L	3041 (310)	2010 (206)	1470 (150)

Note : 1kg = 9.81N

GE Series - Low Assembly Ball Linear Guide

(1) GEH-SA / GEH-CA

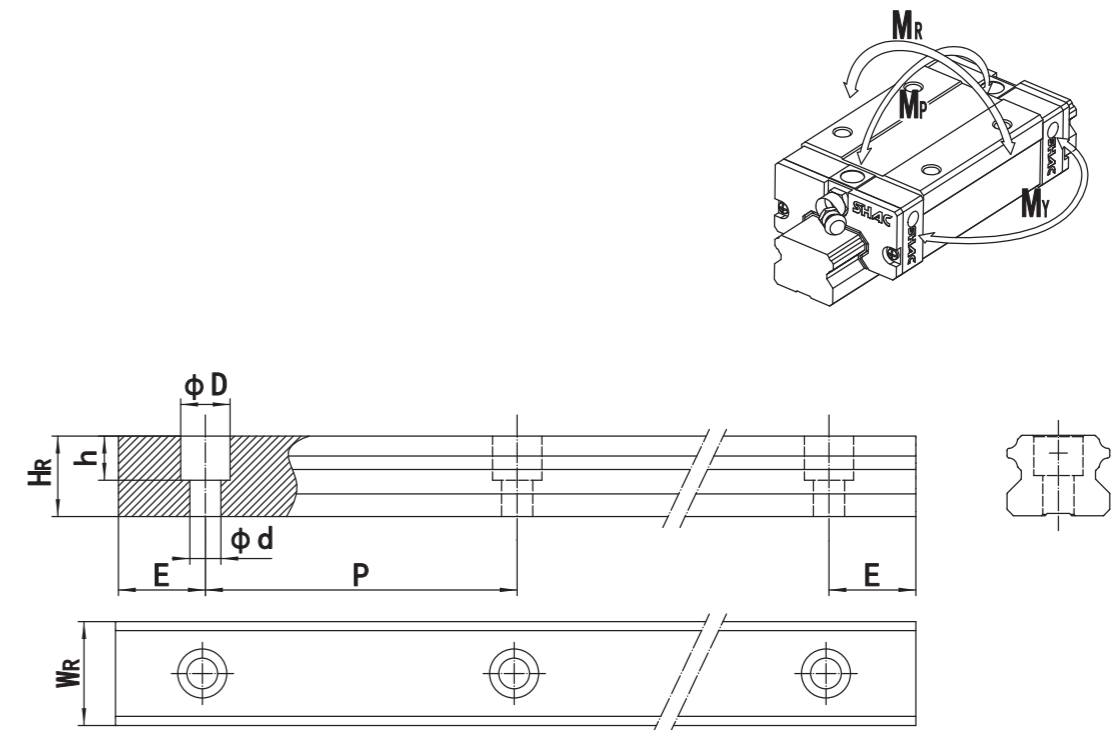
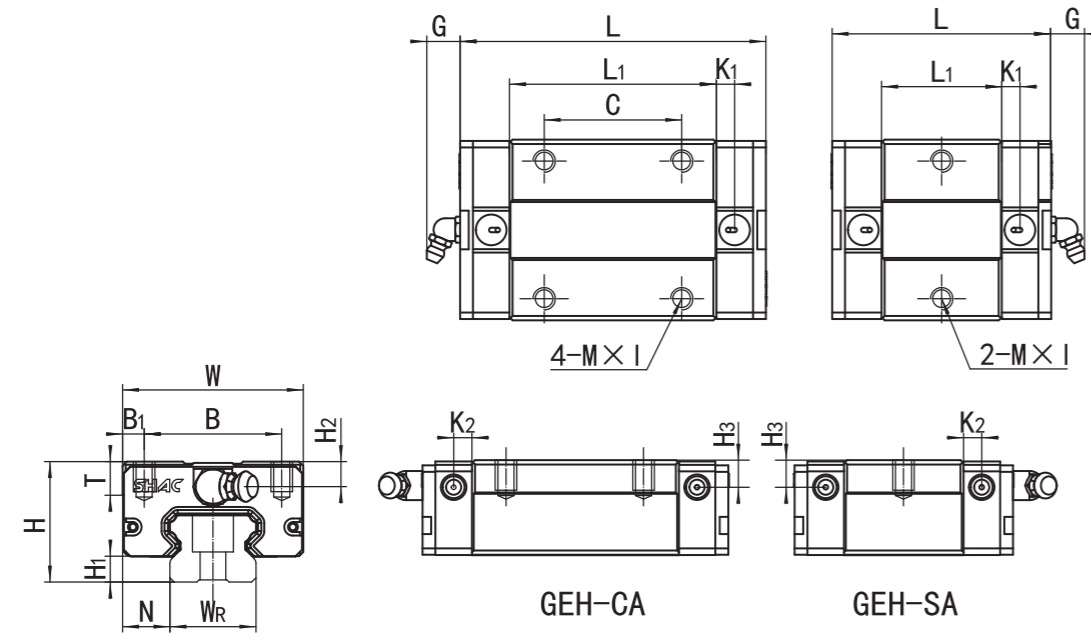

Model No.	Dimensions of Assembly (mm)			Dimensions of Block (mm)												
	H	H ₁	N	W	B	B ₁	C	L ₁	L	K ₁	K ₂	G	M*L	T	H ₂	H ₃
★ GEH15SA	24	4.4	9.5	34	26	4	-	23.1	39.7	3.4	3.4	5.5	M4×6	6	5.5	5.5
GEH15CA							26	39.8	56.4							
★ GEH15SA	24	4.4	9.5	34	26	4	-	23.1	39.7	3.4	3.4	5.5	M4×6	6	5.5	5.5
GEH15CA							26	39.8	56.4							
★ GEH20SA	28	6	11	42	32	5	-	29	50.2	4.2	4.2	12	M5×7	7.5	5.8	6.3
GEH20CA							32	48.1	69.3							
★ GEH25SA	33	6.2	12.5	48	35	6.5	-	35.5	59.5	5	5	12	M6×9	8	7.4	7.4
GEH25CA		6.9					35	59	83.1							
★ GEH30SA	42	10	16	60	40	10	-	41.5	69.5	6	6	12	M8×12	9	9	9
GEH30CA							40	70	98							
★ GEH30SA	42	10	16	60	40	10	-	41.5	69.5	6	6	12	M8×12	9	9	9
GEH30CA							40	70	98							
★ GEH35SA	48	11	18	70	50	10	-	45	75	7	7	12	M8×12	10	8.5	8.5
GEH35CA							50	78	108							

Note : 1KN=100kgf
Models marked with ★ feature small mounting holes. Please confirm with sales before placing your order.

Model No.	Dimensions of Rail(mm)							Mounting Boit for Rail (mm)	Basic Dynamic load Rating C (KN)	Basic Static load Rating C0 (KN)	Static Rated Monent			Weight	
	W _R	H _R	D	h	d	P	E				M _R KN-m	M _P KN-m	M _V KN-m	Block kg	Rail kg/m
★ GE15	15	12.5	6	4.5	3.5	60	20	M3×16	5.99	8.26	0.08	0.04	0.04	0.1	1.26
									8.86	14.46	0.13	0.10	0.10	0.15	
★ GE15U	15	12.5	7.5	5.3	4.5	60	20	M4×16	5.99	8.26	0.08	0.04	0.04	0.1	1.26
									8.86	14.46	0.13	0.10	0.10	0.15	
★ GE20	20	15.5	9.5	8.5	6	60	20	M5×16	8.65	12.14	0.13	0.06	0.06	0.16	2.09
									12.36	20.24	0.21	0.15	0.15	0.26	
★ GE25	23	18	11	9	7	60	20	M6×20	12.86	16.87	0.22	0.12	0.12	0.28	2.69
									18.99	29.52	0.37	0.31	0.31	0.44	
★ GE30	28	23	11	9	7	80	20	M6×25	18.95	24.28	0.39	0.20	0.20	0.5	4.26
									28	42.49	0.66	0.53	0.53	0.8	
★ GE30U	28	23	14	12	9	80	20	M8×25	18.95	24.28	0.39	0.20	0.20	0.5	4.26
									28	42.49	0.66	0.53	0.53	0.8	
★ GE35	34	27.5	14	12	9	80	20	M8×25	26.27	33.05	0.54	0.30	0.30	0.75	6.11
									38.85	57.84	0.95	0.66	0.66	1.12	

Note : 1kgf = 9.81N

GE Series - Low Assembly Ball Linear Guide

(2) GEW-SA / GEW-CA

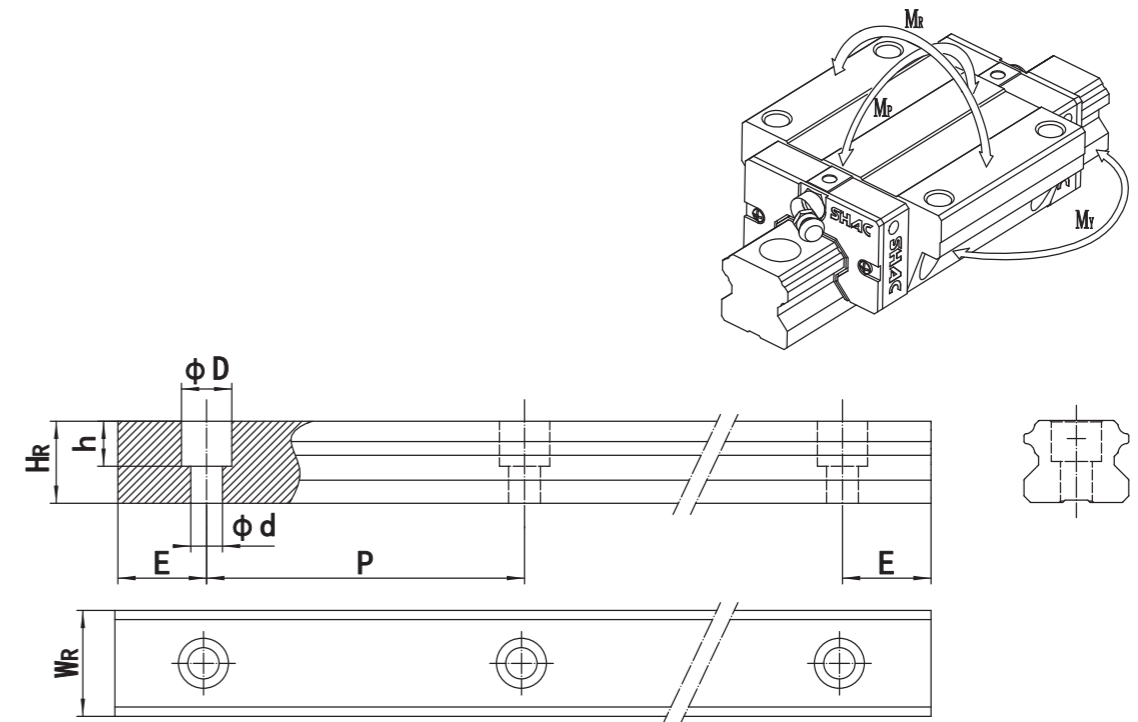
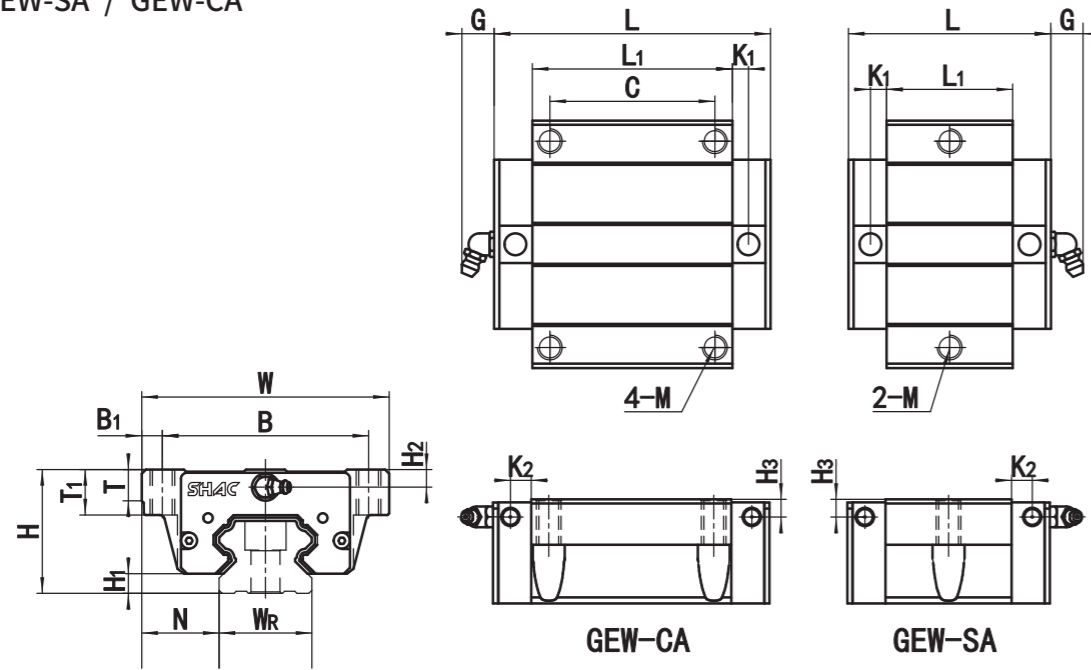

Model No.	Dimensions of Assembly (mm)			Dimensions of Block (mm)														
	H	H ₁	N	W	B	B ₁	C	L ₁	L	K ₁	K ₂	G	M	T	T ₁	H ₂	H ₃	
★ GEW15SA	24	4.4	18.5	52	41	5.5	-	23.1	39.7	3.4	3.4	5.5	M5	5	7.8	5.5	5.5	
GEW15CA							26	39.8	56.4									
★ GEW15SA	24	4.4	18.5	52	41	5.5	-	23.1	39.7	3.4	3.4	5.5	M5	5	7.8	5.5	5.5	
GEW15CA							26	39.8	56.4									
★ GEW20SA	28	6	19.5	59	49	5	-	29	50.2	4.2	4.2	12	M6	7	9	5.8	6.3	
GEW20CA							32	48.1	69.3									
★ GEW25SA	33	6.2	25	73	60	6.5	-	35.5	59.5	5	5	12	M8	7.5	10	7.4	7.4	
GEW25CA		6.9					35	59	83.1									
★ GEW30SA	42	10	31	90	72	9	-	41.5	69.5	6	6	12	M10	7	10	9	9	
GEW30CA							40	70	98									
★ GEW30SA	42	10	31	90	72	9	-	41.5	69.5	6	6	12	M10	7	10	9	9	
GEW30CA							40	70	98									
★ GEW35SA	48	11	33	100	82	9	-	45	75	7	7	12	M10	10	13	8.5	8.5	
GEW35CA							50	78	108									

Note : 1KN=100kgf
Models marked with ★ feature small mounting holes. Please confirm with sales before placing your order.

Model No.	Dimensions of Rail(mm)								Mounting Bolt for Rail (mm)	Basic Dynamic load Rating C (KN)	Basic Static load Rating C0 (KN)	Static Rated Moment			Weight	
	W _R	H _R	D	h	d	P	E	M _R KN-m				M _P KN-m	M _V KN-m	Block kg	Rail kg/m	
★ GE15	15	12.5	6	4.5	3.5	60	20	M3×16	5.99	8.26	0.08	0.04	0.04	0.13	1.26	
GE15U									8.86	14.46	0.13	0.10	0.10	0.12		
★ GE20	20	15.5	9.5	8.5	6	60	20	M5×16	8.65	12.14	0.13	0.06	0.06	0.21	2.09	
GE20U									12.36	20.24	0.21	0.15	0.15	0.33		
★ GE25	23	18	11	9	7	60	20	M6×20	12.86	16.87	0.22	0.12	0.12	0.34	2.69	
GE25U									18.99	29.52	0.37	0.31	0.31	0.59		
★ GE30	28	23	11	9	7	80	20	M6×25	18.95	24.28	0.39	0.20	0.20	0.63	4.26	
GE30U									28	42.49	0.66	0.53	0.53	0.99		
★ GE35	34	27.5	14	12	9	80	20	M8×25	18.95	24.28	0.39	0.20	0.20	0.63	4.26	
GE35U									28	42.49	0.66	0.53	0.53	0.99		
★ GE35	34	27.5	14	12	9	80	20	M8×25	26.27	33.05	0.54	0.30	0.30	0.75	6.11	
GE35U									38.85	57.84	0.95	0.66	0.66	1.12		

Note : 1kgf = 9.81N

GE Series - Low Assembly Ball Linear Guide

(3) GEW-SB / GEW-CB

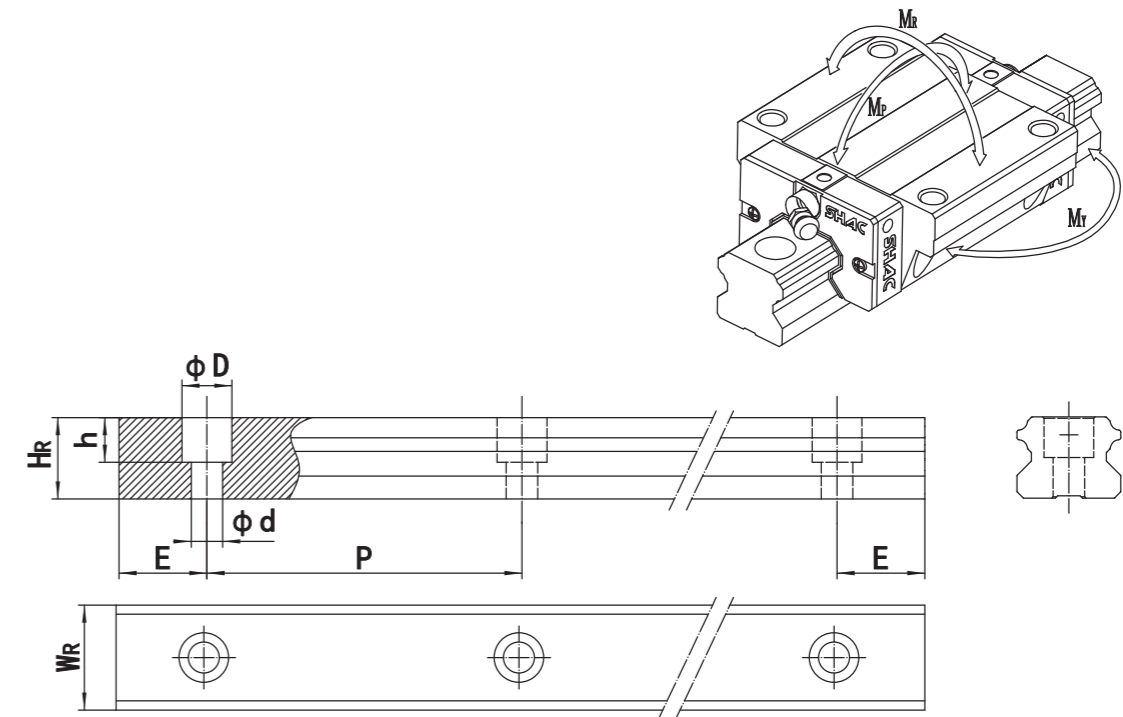
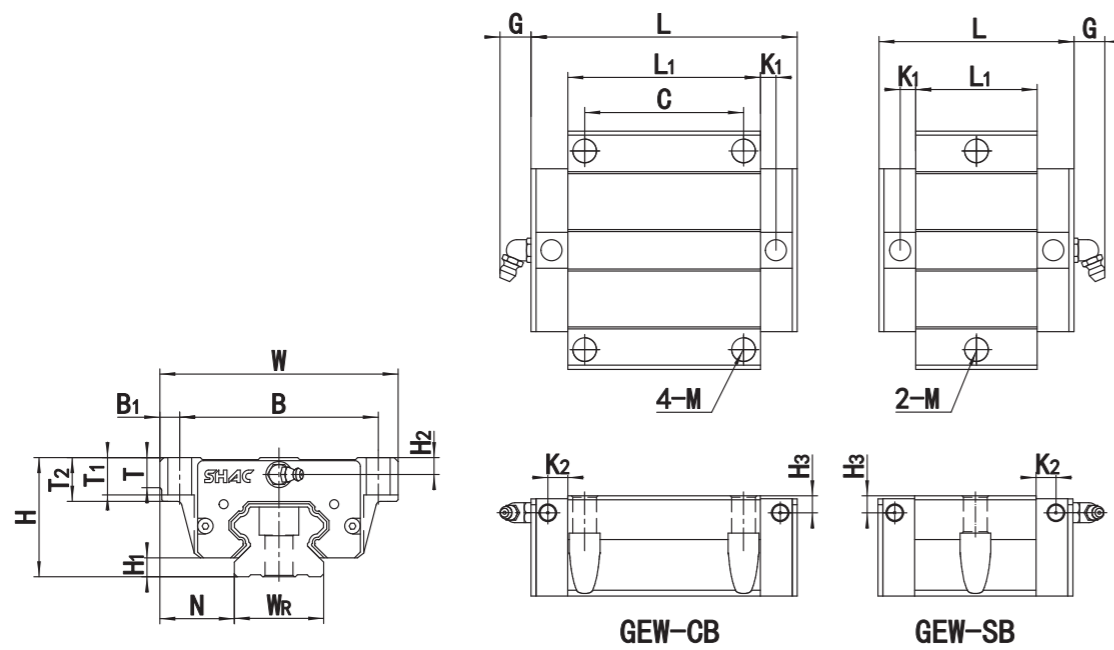

Model No.	Dimensions of Assembly (mm)			Dimensions of Block (mm)														
	H	H ₁	N	W	B	B ₁	C	L ₁	L	K ₁	K ₂	G	M	T	T ₁	T ₂	H ₂	H ₃
★ GEW15SB	24	4.4	18.5	52	41	5.5	-	23.1	39.7	3.4	3.4	5.5	φ4.5	5	7	7.8	5.5	5.5
GEW15CB							26	39.8	56.4									
★ GEW20SB	28	6	19.5	59	49	5	-	29	50.2	4.2	4.2	12	φ5.5	7	8.5	9	5.8	6.3
GEW20CB							32	48.1	69.3									
★ GEW25SB	33	6.2	25	73	60	6.5	-	35.5	59.5	5	5	12	φ7	7.5	9.5	10	7.4	7.4
GEW25CB		6.9					35	59	83.1									
★ GEW30SB	42	10	31	90	72	9	-	41.5	69.5	6	6	12	φ9	7	9.5	10	9	9
GEW30CB							40	70	98									
★ GEW35SB	48	11	33	100	82	9	-	45	75	7	7	12	φ9	10	13	13	8.5	8.5
GEW35CB							50	78	108									

Note : 1KN=100kgf
Models marked with ★ feature small mounting holes. Please confirm with sales before placing your order.

Model No.	Dimensions of Rail(mm)						Mounting Bolt for Rail (mm)	Basic Dynamic load Rating C (KN)	Basic Static load Rating C0 (KN)	Static Rated Moment			Weight		
	WR	HR	D	h	d	P				E	MR KN-m	MP KN-m	MY KN-m	Block kg	Rail kg/m
★ GE15	15	12.5	6	4.5	3.5	60	20	M3×16	5.99	8.26	0.08	0.04	0.04	0.13	1.26
GE15U									8.86						
★ GE20	20	15.5	9.5	8.5	6	60	20	M5×16	8.65	12.14	0.13	0.06	0.06	0.21	2.09
GE20U									12.36						
★ GE25	23	18	11	9	7	60	20	M6×20	12.86	16.87	0.22	0.12	0.12	0.34	2.69
GE25U									18.99						
★ GE30	28	23	11	9	7	80	20	M6×25	18.95	24.28	0.39	0.20	0.20	0.63	4.26
GE30U									28						
★ GE35	34	27.5	14	12	9	80	20	M8×25	18.95	24.28	0.39	0.20	0.20	0.63	4.26
GE35U									28						
★ GE35	34	27.5	14	12	9	80	20	M8×25	26.27	33.05	0.54	0.30	0.30	0.75	6.11
GE35U									38.85						

Note : 1kgf = 9.81N

GE Series - Low Assembly Ball Linear Guide

(4) GEW-SC / GEW-CC

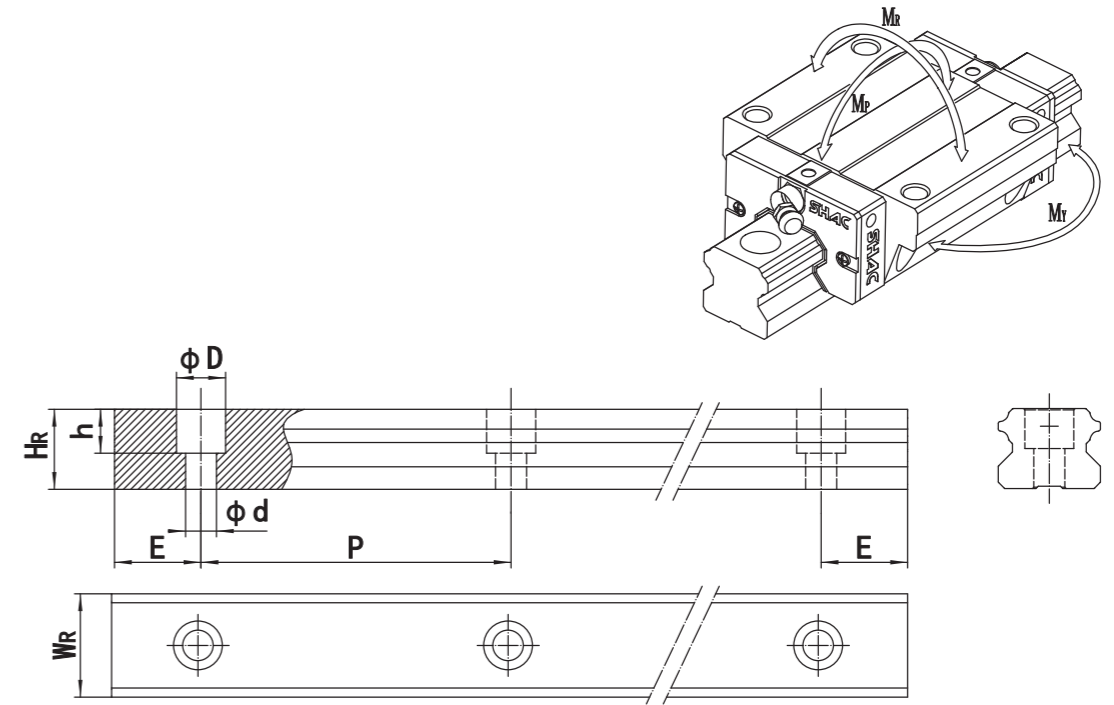
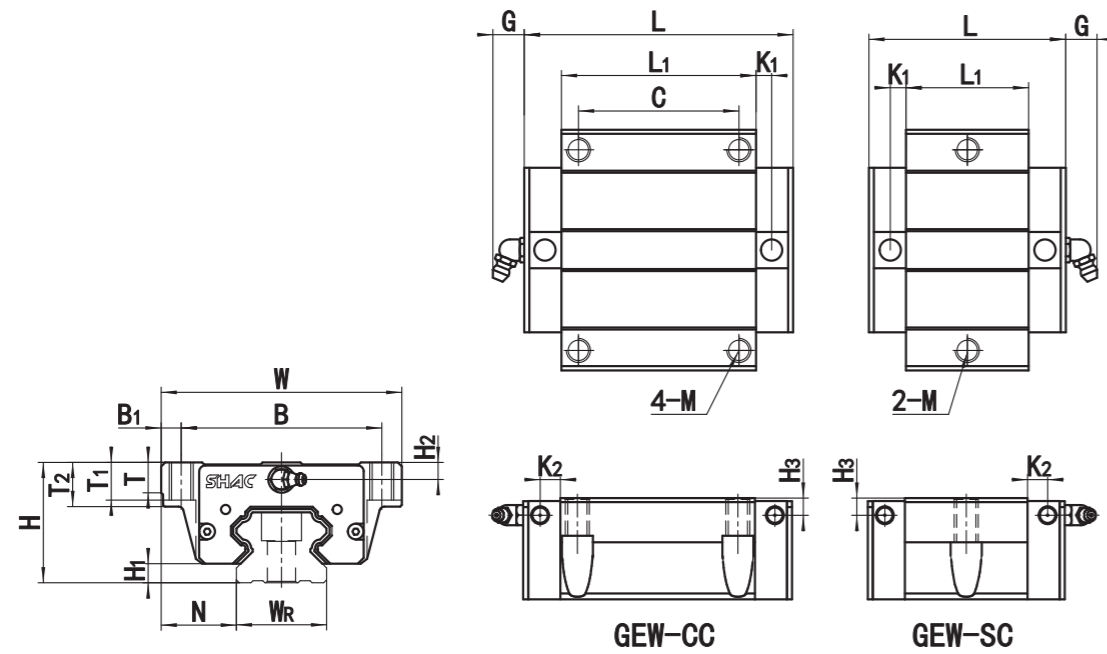

Model No.	Dimensions of Assembly (mm)			Dimensions of Block (mm)														
	H	H ₁	N	W	B	B ₁	C	L ₁	L	K ₁	K ₂	G	M	T	T ₁	T ₂	H ₂	H ₃
★ GEW15SC	24	4.4	18.5	52	41	5.5	-	23.1	39.7	3.4	3.4	5.5	M5	5	7	7.8	5.5	5.5
GEW15CC							26	39.8	56.4									
★ GEW20SC	28	6	19.5	59	49	5	-	29	50.2	4.2	4.2	12	M6	7	8.5	9	5.8	6.3
GEW20CC							32	48.1	69.3									
★ GEW25SC	33	6.2	25	73	60	6.5	-	35.5	59.5	5	5	12	M8	7.5	9.5	10	7.4	7.4
GEW25CC		6.9					35	59	83.1									
★ GEW30SC	42	10	31	90	72	9	-	41.5	69.5	6	6	12	M10	7	9.5	10	9	9
GEW30CC							40	70	98									
★ GEW35SC	48	11	33	100	82	9	-	45	75	7	7	12	M10	10	13	13	8.5	8.5
GEW35CC							50	78	108									

Note : 1KN=100kgf
Models marked with ★ feature small mounting holes. Please confirm with sales before placing your order.

Model No.	Dimensions of Rail(mm)							Mounting Boit for Rail (mm)	Basic Dynamic load Rating C (KN)	Basic Static load Rating C ₀ (KN)	Static Rated Monent			Weight	
	W _R	H _R	D	h	d	P	E				M _R KN-m	M _P KN-m	M _V KN-m	Block kg	Rail kg/m
★ GE15	15	12.5	6	4.5	3.5	60	20	M3×16	5.99	8.26	0.08	0.04	0.04	0.13	1.26
GE15U									8.86	14.46	0.13	0.10	0.10	0.2	
★ GE20	20	15.5	9.5	8.5	6	60	20	M5×16	8.65	12.14	0.13	0.06	0.06	0.21	2.09
GE20U									12.36	20.24	0.21	0.15	0.15	0.33	
★ GE25	23	18	11	9	7	60	20	M6×20	12.86	16.87	0.22	0.12	0.12	0.34	2.69
GE25U									18.99	29.52	0.37	0.31	0.31	0.59	
★ GE30	28	23	11	9	7	80	20	M6×25	18.95	24.28	0.39	0.20	0.20	0.63	4.26
GE30U									28	42.49	0.66	0.53	0.53	0.99	
★ GE35	34	27.5	14	12	9	80	20	M8×25	18.95	24.28	0.39	0.20	0.20	0.63	4.26
GE35U									28	42.49	0.66	0.53	0.53	0.99	
★ GE35	34	27.5	14	12	9	80	20	M8×25	26.27	33.05	0.54	0.30	0.30	0.75	6.11
GE35U									38.85	57.84	0.95	0.66	0.66	1.12	

Note : 1kgf = 9.81N

LE Series - Low assembly ball type (injection structure type)

(5) LEH-SA / LEH-CA

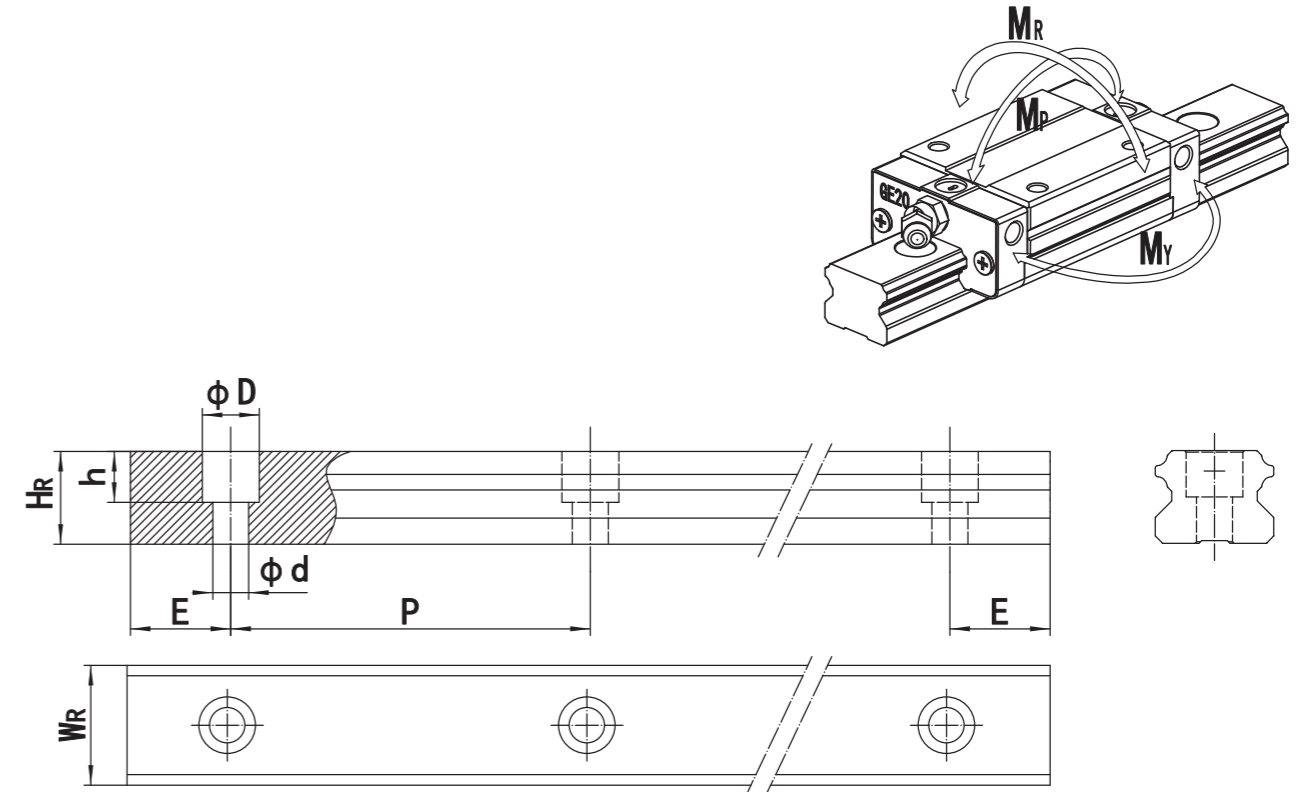
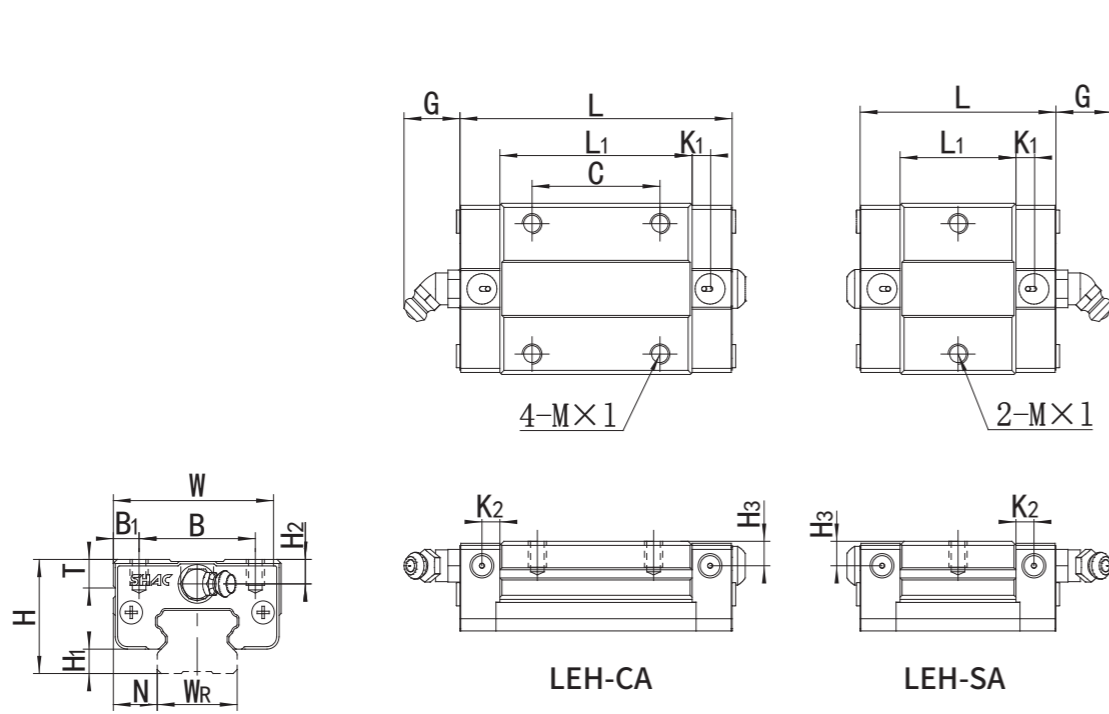

Model No.	Dimensions of Assembly (mm)			Dimensions of Block (mm)													
	H	H ₁	N	W	B	B ₁	C	L ₁	L	K ₁	K ₂	G	M*L	T	H ₂	H ₃	
★ LEH15SA	24	4.5	9.5	34	26	4	-	23.1	41.1	3.5	3.5	7	M4×6	6	5.5	5	
LEH15CA							26	39.8	57.8								
★ LEH20SA	28	6	11	42	32	5	-	29	49	4.5	4.5	12	M5×7	7.5	6	6	
LEH20CA							32	48.1	68.1								
★ LEH25SA	33	7	12.5	48	35	6.5	-	35.5	57.5	4.5	5.2	12	M6×9	8	8	8	
LEH25CA							35	59	81								

Note : 1KN=100kgf
Models marked with ★ feature small mounting holes. Please confirm with sales before placing your order.

Model No.	Dimensions of Rail(mm)								Mounting Boit for Rail (mm)	Basic Dynamic load Rating C (KN)	Basic Static load Rating Co (KN)	Static Rated Monent			Weight	
	W _r	H _r	D	h	d	P	E	MR KN-m				MP KN-m	MY KN-m	Block kg	Rail kg/m	
LE15	15	12.5	6	4.5	3.5	60	20	M3×16	6.05	8.26	0.08	0.04	0.04	0.12	1.26	
LE15U											0.13	0.10	0.10	0.17		
LE20	20	15.5	9.5	8.5	6	60	20	M5×16	9.03	12.14	0.13	0.06	0.06	0.19	2.09	
LE25									12.56	20.24	0.21	0.15	0.15	0.31		
LE25	23	18	11	9	7	60	20	M6×20	13.04	16.87	0.22	0.12	0.12	0.33	2.69	
LE25									19.32	29.52	0.37	0.31	0.31	0.51		

Note : 1kgf = 9.81N

LE Series - Low assembly ball type (injection structure type)

(6) LEW-SC / LEW-CC

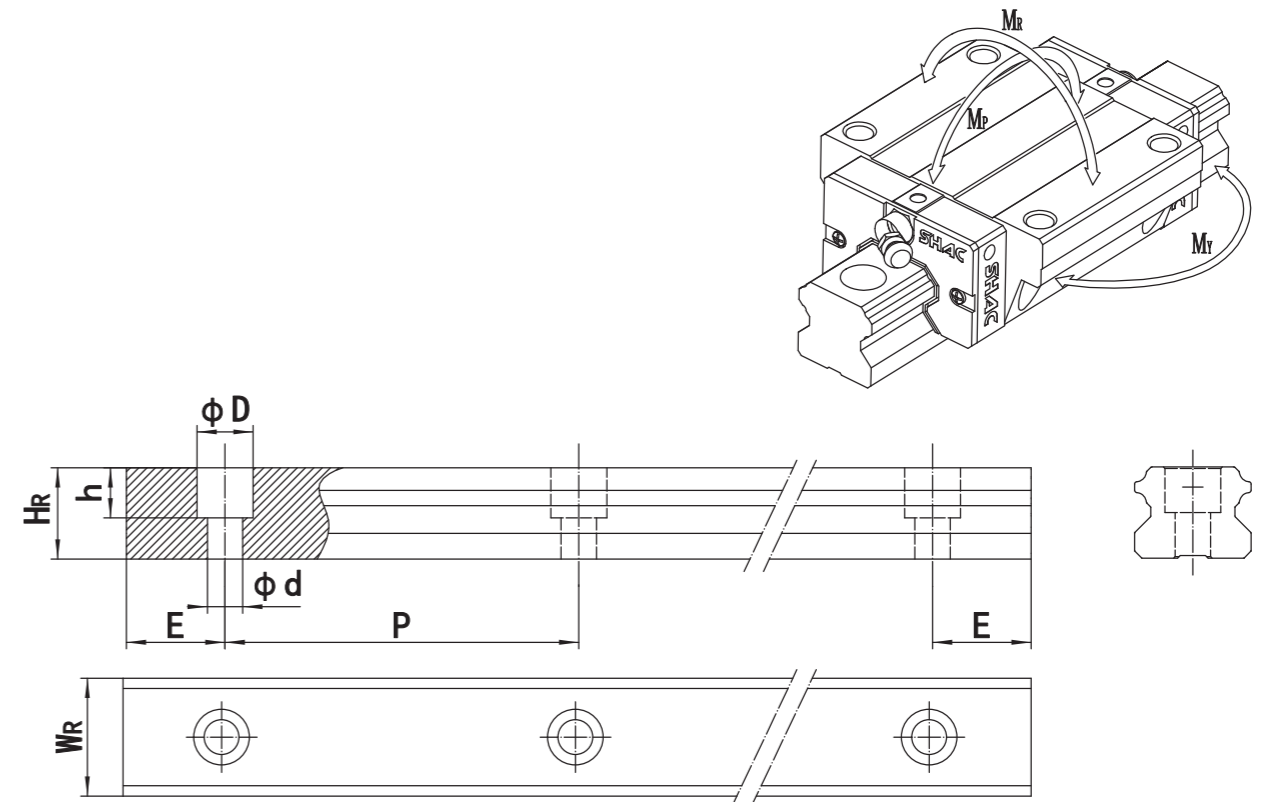
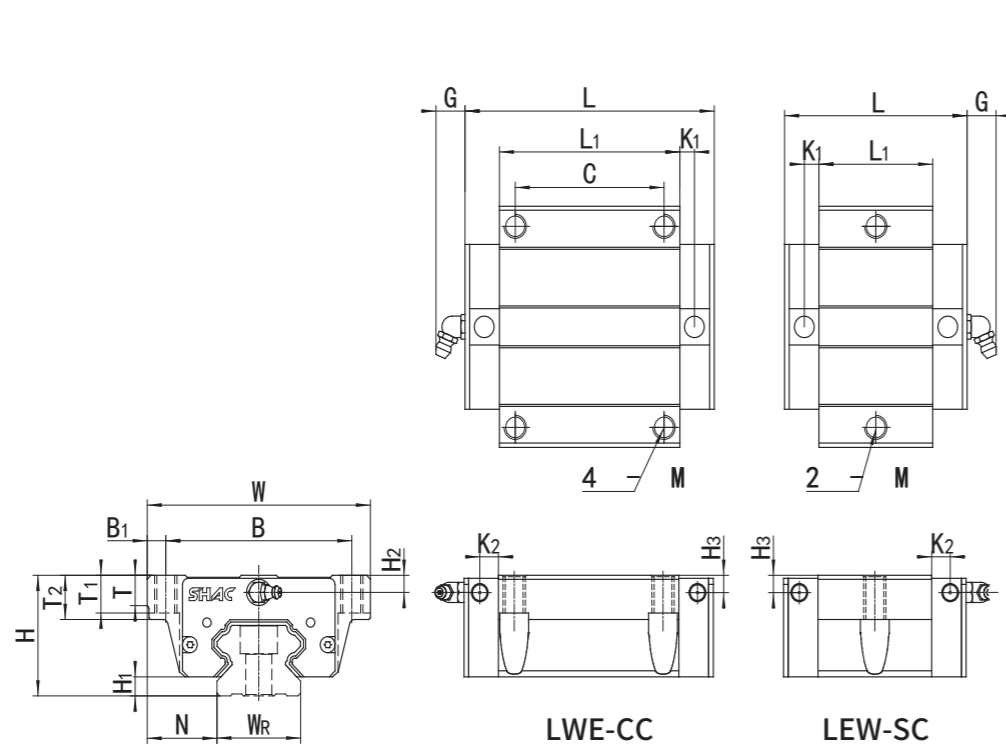

Model No.	Dimensions of Assembly (mm)			Dimensions of Block (mm)														
	H	H ₁	N	W	B	B ₁	C	L ₁	L	K ₁	K ₂	G	M	T	T ₁	T ₂	H ₂	H ₃
★ LEW15SC	24	4.5	18.5	52	41	5.5	-	23.1	41.1	3.5	3.5	7	M5	5	7	7.8	5.5	5
LEW15CC							26	39.8	57.8									
★ LEW15SC	24	4.5	18.5	52	41	5.5	-	23.1	41.1	3.5	3.5	7	M5	5	7	7.8	5.5	5
LEW15CC							26	39.8	57.8									
★ LEW20SC	28	6	19.5	59	49	5	-	29	49	4.5	4.5	12	M6	7	8.5	9	6	6
LEW20CC							32	48.1	68.1									
★ LEW25SC	33	7	25	73	60	6.5	-	35.5	57.5	4.5	5.2	12	M8	7.5	9.5	10	8	8
LEW25CC							35	59	81									

Note : 1KN=100kgf
Models marked with ★ feature small mounting holes. Please confirm with sales before placing your order.

Model No.	Dimensions of Rail(mm)							Mounting Bolt for Rail (mm)	Basic Dynamic load Rating C (KN)	Basic Static load Rating Co (KN)	Static Rated Moment			Weight	
	W _R	H _R	D	h	d	P	E				MR KN-m	MP KN-m	MY KN-m	Block kg	Rail kg/m
LE15	15	12.5	6	4.5	3.5	60	20	M3×16	6.05	8.26	0.08	0.04	0.04	0.15	1.26
									8.98	14.46	0.13	0.10	0.10	0.22	
LE15U	15	12.5	7.5	5.3	4.5	60	20	M4×16	6.05	8.26	0.08	0.04	0.04	0.15	1.26
									8.98	14.46	0.13	0.10	0.10	0.22	
LE20	20	15.5	9.5	8.5	6	60	20	M5×16	9.03	12.14	0.13	0.06	0.06	0.25	2.09
									12.56	20.24	0.21	0.15	0.15	0.36	
LE25	23	18	11	9	7	60	20	M6×20	13.04	16.87	0.22	0.12	0.12	0.37	2.69
									19.32	29.52	0.37	0.31	0.31	0.62	

Note : 1kgf = 9.81N

GE Series - Low Assembly Ball Linear Guide

(7) Dimension Table of GER-T Bottom Lock Guide Rail

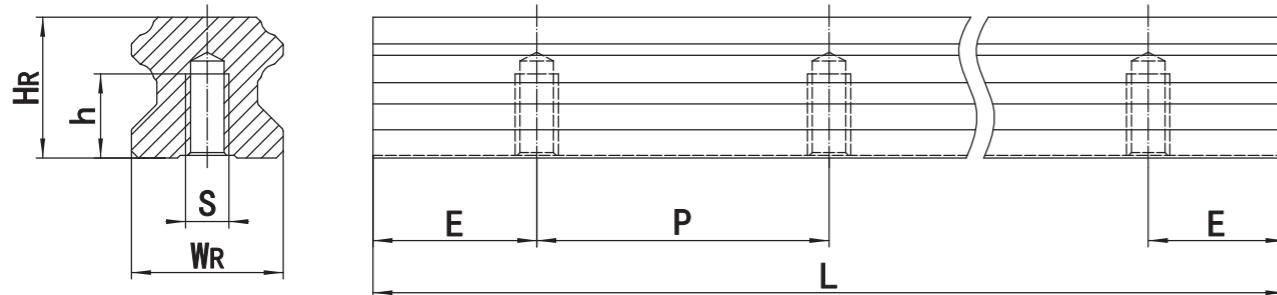

Model No.	Dimensions of Rail (mm)						Weight (kg/m)
	W _R	H _R	S	h	P	E	
GER15T	15	12.5	M5×0.8P	7	60	20	1.26
GER20T	20	15.5	M6×1P	9	60	20	2.15
GER25T	23	18	M6×1P	10	60	20	2.79
GER30T	28	23	M8×1.25P	14	80	20	4.42
GER35T	34	27.5	M8×1.25P	17	80	20	6.34

2-4 QH Series - Silent Heavy Duty Ball Linear Guide

SHAC's QH series silent linear guideway is a high-performance linear guideway actively developed to enhance competitive advantage, based on a four-row single-arc tooth profile design. The QH series linear guideway with SynchMotion™ technology is equipped with a patented synchronous connector with oil storage function, which can effectively reduce noise during operation and improve operational smoothness, lifespan, and lubrication efficiency. The QH series linear guideway with SynchMotion™ technology has a wider range of industrial applications and is more suitable for high-tech industries that require high speed, quiet operation, and low dust generation.

Products Characteristic

Low noise

Using a synchronous connector can ensure that steel balls are evenly and equally spaced, preventing mutual collisions between them and effectively reducing the intensity of high-frequency sharp sounds (see the lower right image). Compared to the previous series, the overall sound intensity can be effectively reduced by about 5 decibels (see the lower left image).

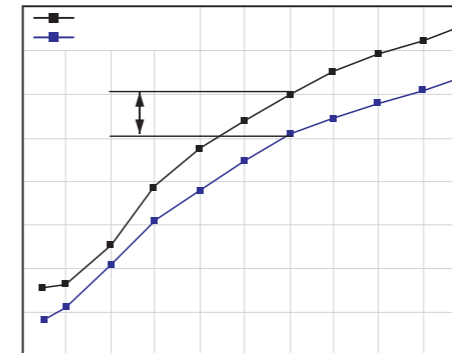

Figure 2-3-1

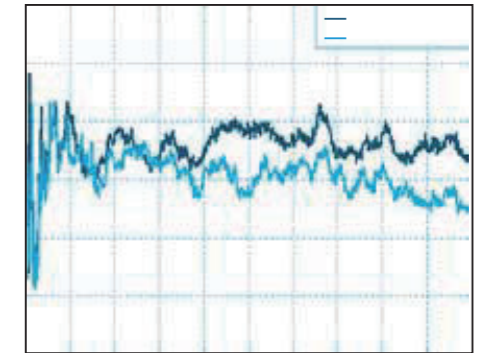

Figure 2-3-2

Self-lubricating

The patented synchronous connector features a space for oil storage in the middle spacer, which can provide lubrication for the steel balls during operation. When passing through the direction-turning part, it can evenly replenish the lubricating oil in the oil storage space, continuing to lubricate the steel balls evenly. Therefore, the frequency of replenishing lubricating oil can be effectively reduced. The test data in Table 2-3-1 shows that by adding high-performance lithium soap-based grease before leaving the factory, it can sustain a service life of over 4,000 kilometers under 0.2 times the rated dynamic load without experiencing fatigue damage. Therefore, by adding high-performance lubricating grease at the factory, it can ensure its service life without requiring maintenance under normal light load conditions.

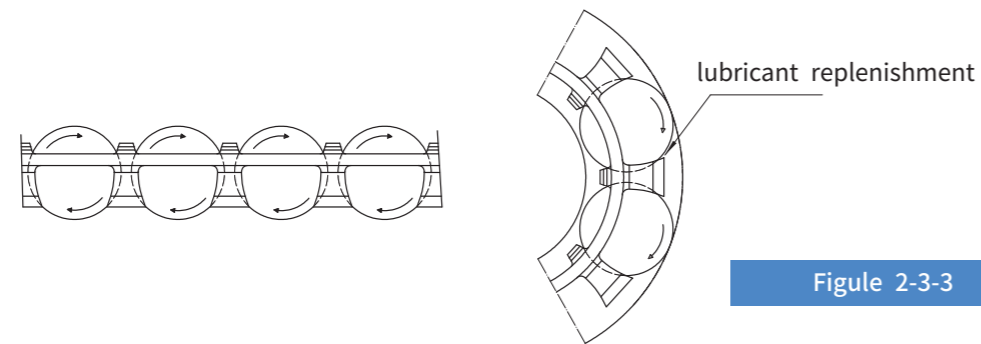

Figure 2-3-3

Table 2-3-1 Self-lubrication Test Data

specimen	QHH25CAZAH	load testing
speed	24m/min	
lubrican	Lithium soap-based grease (initial addition)	
Load	5kN	
walking distance	4,000 kilometer	

Good smoothness

The steel ball chain belt enables the steel balls to be arranged evenly and equidistant. When the sliding block starts to operate, the steel ball in the non-load area will start synchronously with the steel ball in the load area under the drive of the chain belt, so as to significantly reduce the variation range of friction resistance and bring better walking smoothness

Frictional resistance test diagram

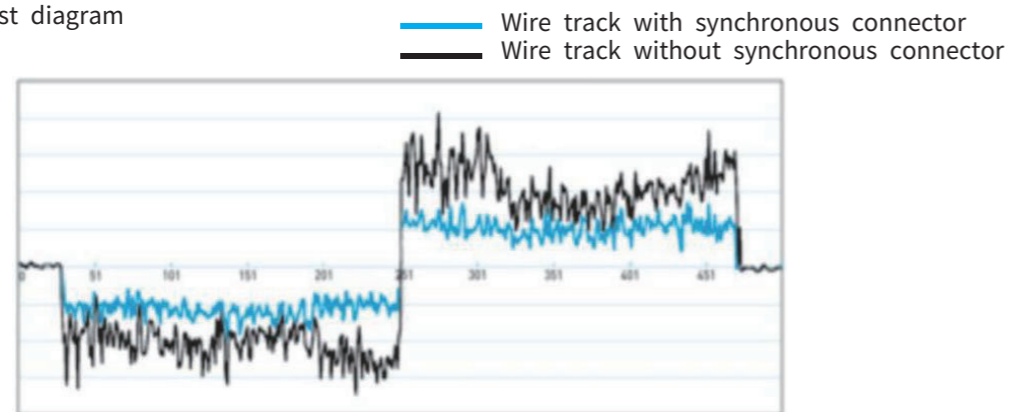

Figure 2-3-4

High-speed Design

The spacer design of the SynchMotion™ synchronizer eliminates the mutual friction between steel balls, and the patented design of SHAH ensures that the steel balls make circular linear contact with the synchronizer, thereby effectively reducing the friction coefficient. This makes the SynchMotion™ silent linear guideway exhibit excellent high-speed performance

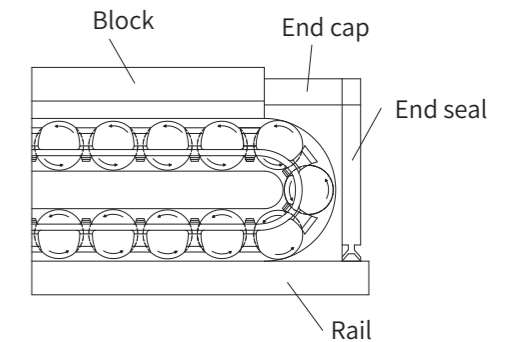
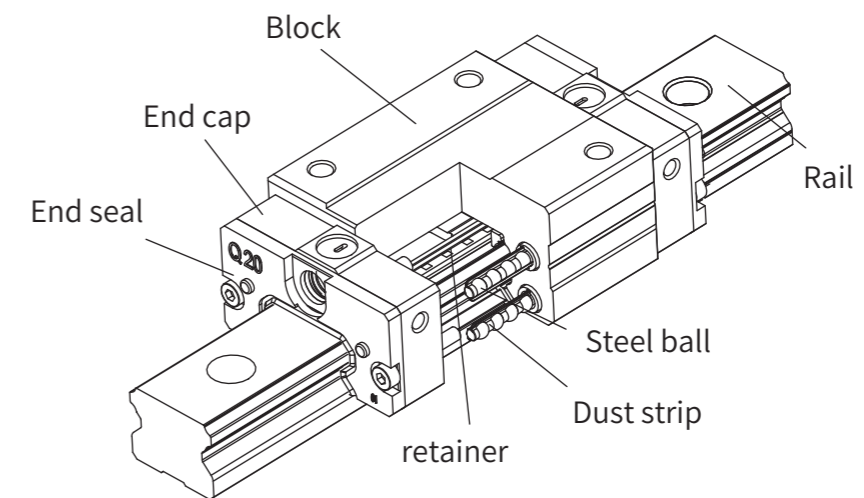

Figure 2-3-5

Products structure



- ◎Rolling cycle system: slider guide rail, end cover, steel ball and steel ball retainer
- ◎Lubrication system: nozzle, oil pipe joint, end cover, steel ball, steel ball retainer
- ◎Dust prevention system: dust strip, bottom dust seal dust strip, guide rail cap, metal scraper

Figure 2-3-6

2-4-1 Product model of non-interchangeable linear guide rail

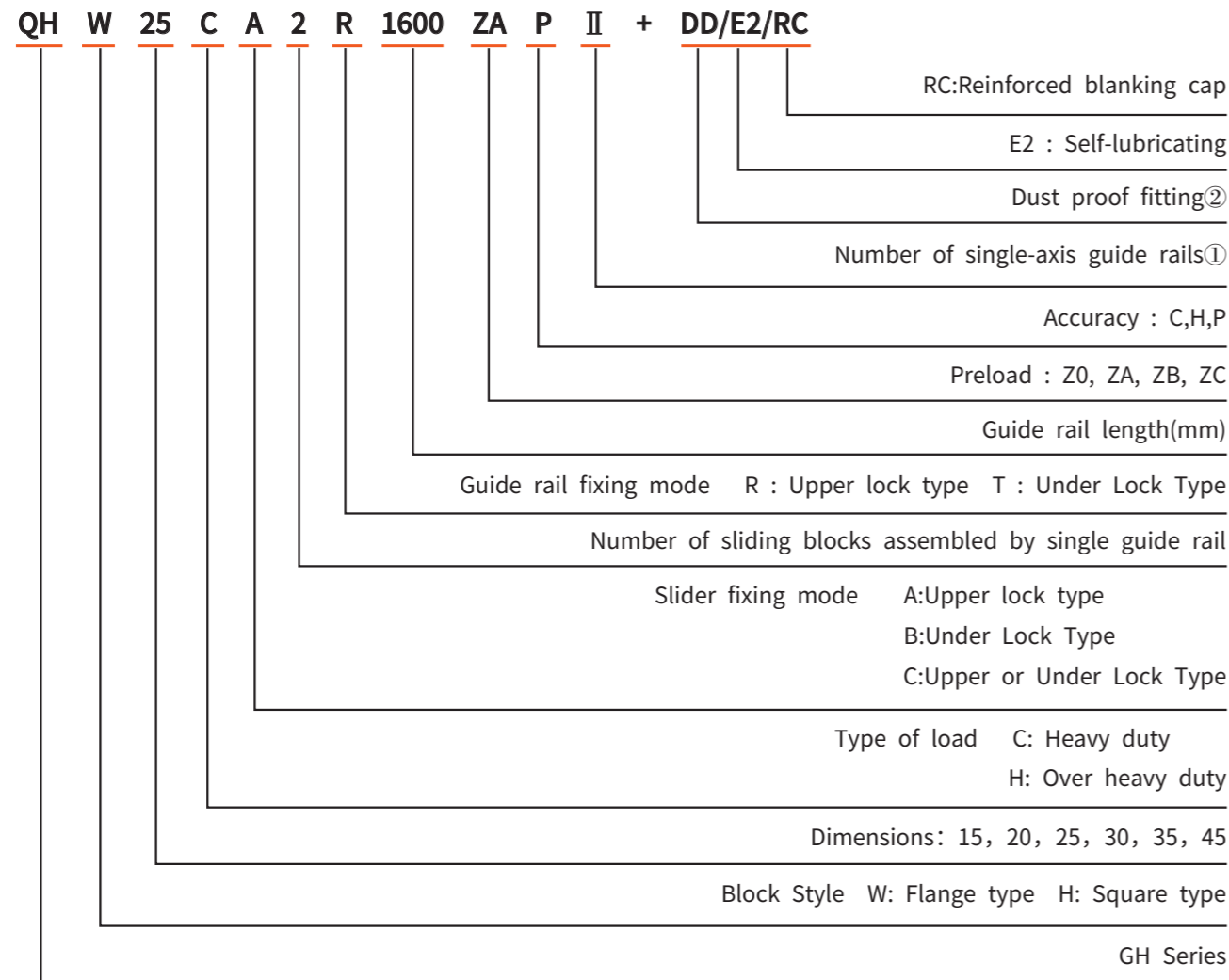

Note:

- The number of single-axis guide rails shall not be written if only — support guide rails are used. Two guide rails are marked as II, three guide rails are marked as III, and so on.
- The dust proof accessories with several weights are standard dust proof accessories with dust strip.
 ZZ: dust strip, dust strip and metal scraper.
 KK is double dust proof, dust strip and metal scraper.
 DD DUAL DUST FINS WITH DUST STRIPS.
 1.The sliding block type L is the low assembled sliding block of square type H, and the combined height is consistent with the flange type of the same size.

2-4-2 Product model of interchangeable linear guide rail

Product model of interchangeable block

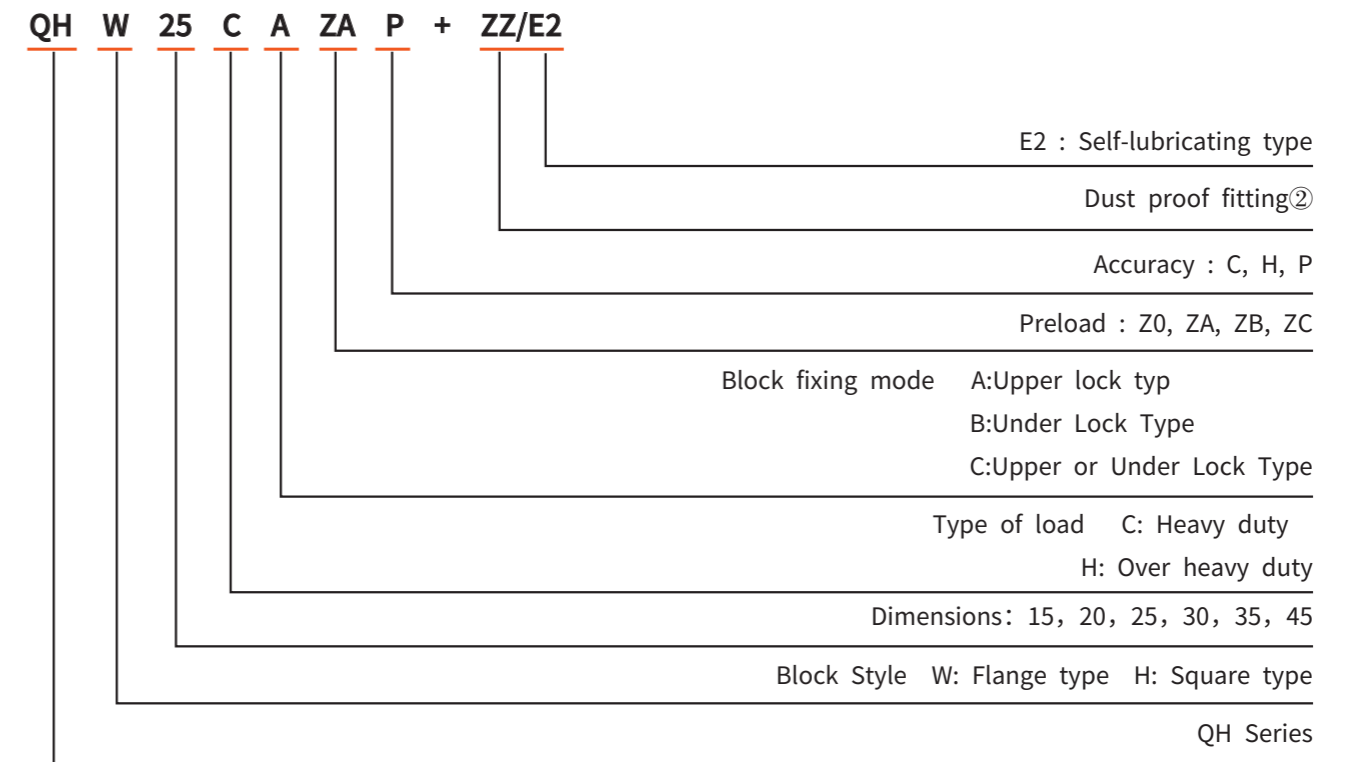

Product model of interchangeable rail

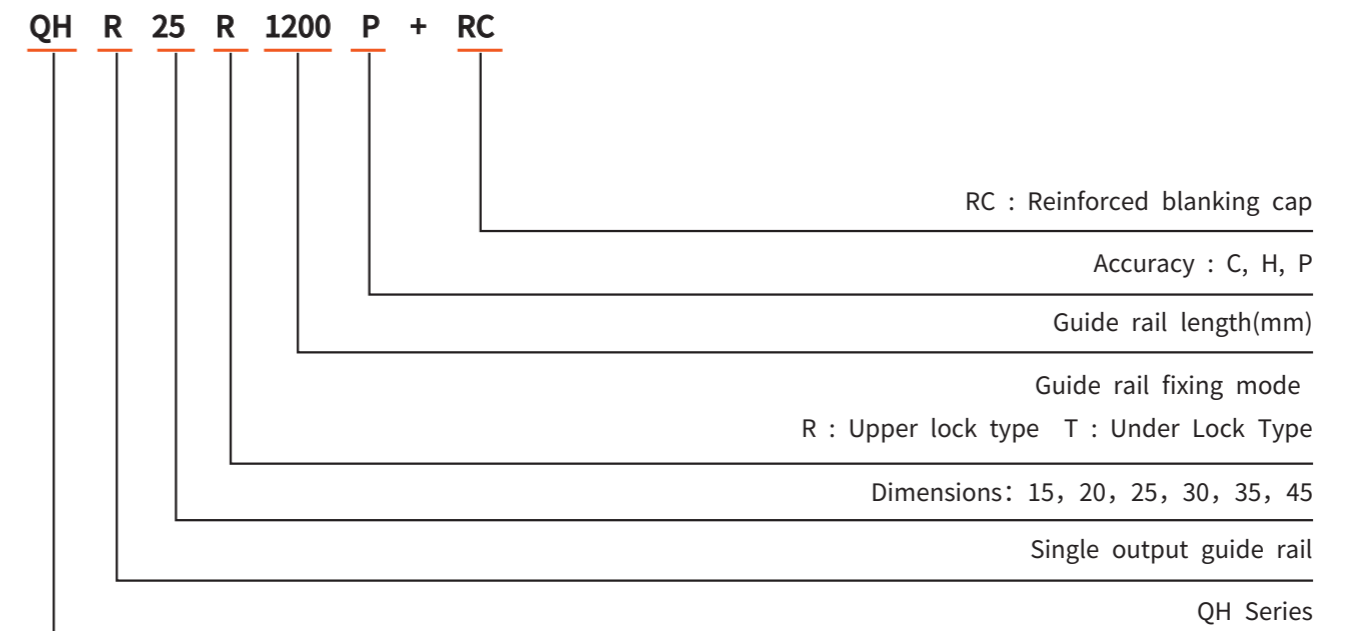

2-4-3 QH Series - Silent Heavy Duty Ball Linear Guide

(1) QH block type

SHAC provides flange type and square type linear guide rails. The overall assembly height of flange row is lower and wider. The threaded holes and through holes machined at the flange part can meet the installation of bottom lock type.

Table 2-3-2 Block Type

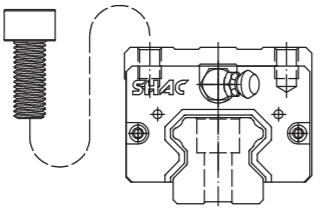
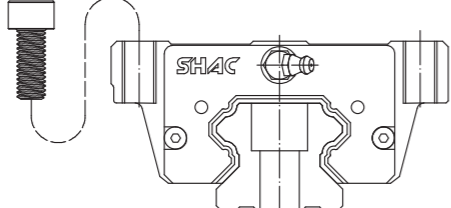
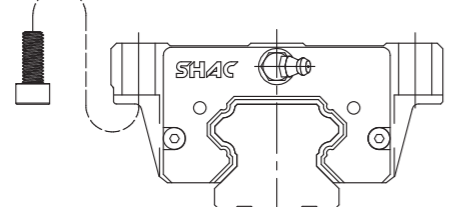
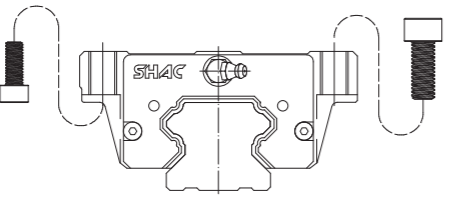
Style	Specification	SHAPE	Height dimension	Guide rail length	Equipment suitable for application
Square	QHH-CA QHH-HA		28	100	<ul style="list-style-type: none"> Measuring instruments Automation device
			70	6000	
Flange	QHW-CA QHW-HA		24	100	<ul style="list-style-type: none"> High speed Transport equipment Semiconductor equipment
			60	6000	
	QHW-CB QHW-HB		24	100	
			60	6000	
QHW-CC QHW-HC		24	100		
		60	6000		

(2) Guideways Type

In addition to the general locking screw hole guide rail, SHAC also provides the lower locking screw hole guide rail. QH series products and GE series share the guide rail, which is convenient for customers to install and use

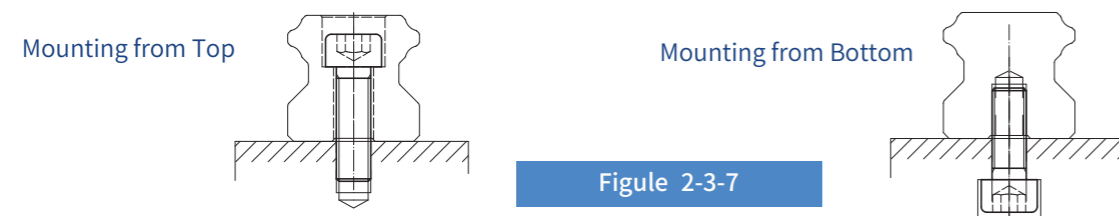

Figure 2-3-7

Grade of accuracy

The accuracy of QH series linear guide rail can be divided into five levels: common level(C), high level (H), precision level(P), ultra-precision level(SP) and ultra-high precision level(UP). Customers can select products of corresponding level according to the equipment accuracy requirements

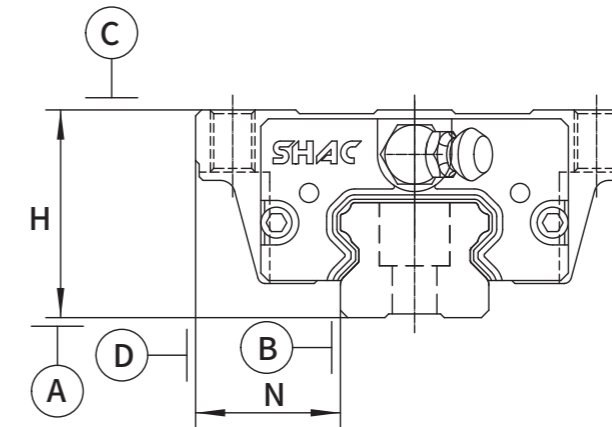

Figure 2-3-8

2-4-4 Precision of non-interchangeable guide rail

Table 2-3-3 Assembly accuracy table

Unit : mm

Model No.	QH-15, 20				
Grade of accuracy	Ultra-Precision Level (UP)	Super-Precision Level (SP)	Precision Level (P)	High Level (H)	Ordinary Level (C)
Allowable dimension error of height H	0 -0.008	0 -0.015	0 -0.03	±0.03	±0.1
Allowable error of width N	0 -0.008	0 -0.015	0 -0.03	±0.03	±0.1
Mutual error of paired width H	0.003	0.004	0.006	0.01	0.02
Allowable error of paired width N	0.003	0.004	0.006	0.01	0.02
Traveling parallelism of slide block C to surface A of guide rail	Travel Parallelism (see Table 2-3-8)				
Traveling parallelism of slide block D to surface B of guide rail					

2-4-5 Interchangeability guide rail accuracy

Table 2-3-4 Assembly accuracy table

Unit : mm

Model No.	QH—25, 30				
Grade of accuracy	Ultra-Precision Level (UP)	Super-Precision Level (SP)	Precision Level (P)	High Level (H)	Ordinary Level (C)
Allowable dimension error of height H	0 -0.01	0 -0.02	0 -0.04	±0.04	±0.1
Allowable error of width N	0 -0.01	0 -0.02	0 -0.04	±0.04	±0.1
Mutual error of paired width H	0.003	0.005	0.007	0.015	0.02
Allowable error of paired width N	0.003	0.005	0.007	0.015	0.03
Traveling parallelism of slide block C to surface A of guide rail	Travel Parallelism (see Table 2-3-8)				
Traveling parallelism of slide block D to surface B of guide rail					

Table 2-3-5 Single Output Accuracy Table

Unit : mm

Model No.	QH—15, 20		
Grade of accuracy	Precision Level (P)	High Level (H)	Ordinary Level (C)
Allowable dimension error of height H	±0.015	±0.03	±0.1
Allowable error of width N	±0.015	±0.03	±0.1
Mutual error of paired width H	0.006	0.01	0.02
Allowable error of paired width N	0.006	0.01	0.02
Traveling parallelism of slide block C to surface A of guide rail	Travel Parallelism (see Table 2-3-8)		
Traveling parallelism of slide block D to surface B of guide rail			

Table 2-3-6 Single Output Accuracy Table

Unit : mm

Model No.	QH—25, 30, 35		
Grade of accuracy	Precision Level (P)	High Level (H)	Ordinary Level (C)
Allowable dimension error of height H	±0.02	±0.04	±0.1
Allowable error of width N	±0.02	±0.04	±0.1
Mutual error of paired width H	0.007	0.015	0.02
Allowable error of paired width N	0.007	0.015	0.03
Traveling parallelism of slide block C to surface A of guide rail	Travel Parallelism (see Table 2-3-8)		
Traveling parallelism of slide block D to surface B of guide rail			

2-4-6 QH Series

◎ Recommended Applicable Equipment

Precision high-speed mute: painting machine, chip related equipment, quiet related equipment, laser engraving machine, etc.

Table 2-3-7

Item	Product advantages	Corresponding efficiency
1	Low shift sound	High-efficiency steel ball circulation Through high-strength synthetic resin accessories and steel ball chain belt design, the steel ball can obtain the best motion path, and the result is effectively reduced by about 5dB compared with GH series
2	Self-lubricating chain belt	There is a certain space between the steel ball and the chain belt to store lubricating grease, ensure the continuous lubrication effect of the steel ball during operation, and effectively improve the smoothness and service life
3	Smooth synchronization	The self-lubricating chain belt arranges the steel balls evenly and equidistant, and the chain belt synchronously starts the steel balls in the non-load area, so as to greatly reduce the variation of friction resistance and effectively improve the walking smoothness
4	High speed chain belt	The combination of chains and belts enables the steel balls to be arranged equidistant to resolve the reverse sliding friction between the steel balls. Combined with self-lubrication, and the annular line contact design between the steel balls and the chains, the friction resistance is effectively reduced to enable the silent line rail to operate at high speed
5	More suitable for preloading	Optional four-level standard preloading can further improve accuracy and rigidity
6	Complete dust prevention accessories	Standard dust proof configuration and optional DD, KK, ZZ dust proof kit
7	Common rail structure	Silent QE and QH share the same rail design, with the combination height unchanged

2-4-7 Traveling parallel precision

Table 2-3-8

Guide rail length (mm)	Grade of accuracy (μm)				
	UP	SP	P	H	C
~100	2	2	3	7	12
100~200	2	2	4	9	14
200~300	2	3	5	10	15
300~500	2	3	6	12	17
500~700	2	4	7	13	20
700~900	3	5	8	15	22
900~1100	3	6	9	16	24
1100~1500	4	7	11	18	26
1500~1900	4	8	13	20	28
1900~2500	5	10	15	22	31
2500~3100	6	11	18	25	33
3100~3600	7	14	20	27	36
3600~4000	7	15	21	28	37

Preload

The so-called preloading is to increase the diameter of the steel ball to produce negative pressure between the steel ball and the channel

Clearances, pre-applied loads internally. Clearance is not only eliminated by assembly with preload It can also improve the rigidity and precision of the sliding block.

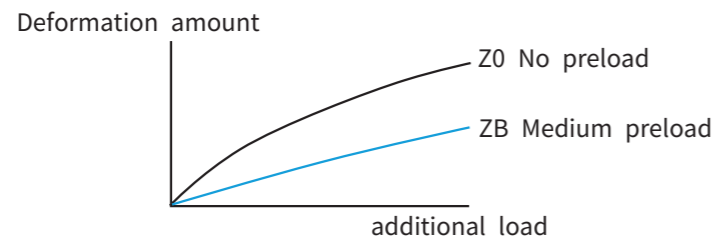

Figure 2-3-9

2-4-8 Grade of Preload

The QH series linear guide rail provides three standard preloads, which can be selected according to the application

Table 2-3-9 Grade of preload

Degree of preload	Code	Preload	Scopes of application
No preload	Z0	0~0.02C	Fixed load direction, small impact and low precision requirements
Light preload	ZA	0.02C~0.04C	Light duty and high accuracy required
Medium preload	ZB	0.04C~0.08C	High rigidity, vibration and impact environment
Heavy preload	ZC	0.08C~0.12C	A usage environment that requires higher rigidity, vibration, and high impact force.
Assembly mode	Non-interchangeable track (single output)		Non-interchangeable track (single output)
Grade of preload	Z0、ZA		Z0、ZA、ZB

Note : C in the pre-pressure is the dynamic rated load

2-4-9 Lubrication frequency

Dust proof fitting and code

Grease shall be confirmed every 100km or every 3-6 months.

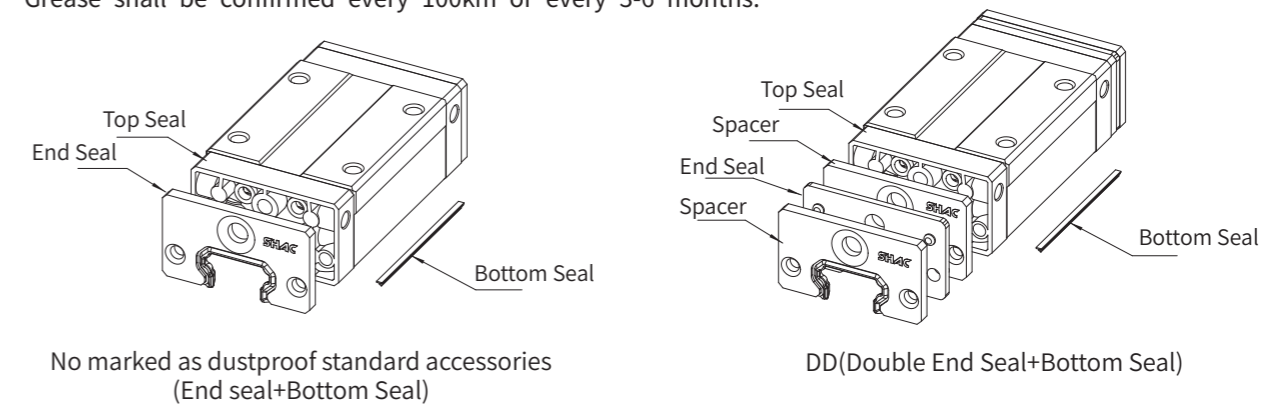

Figure 2-3-10

Figure 2-3-11

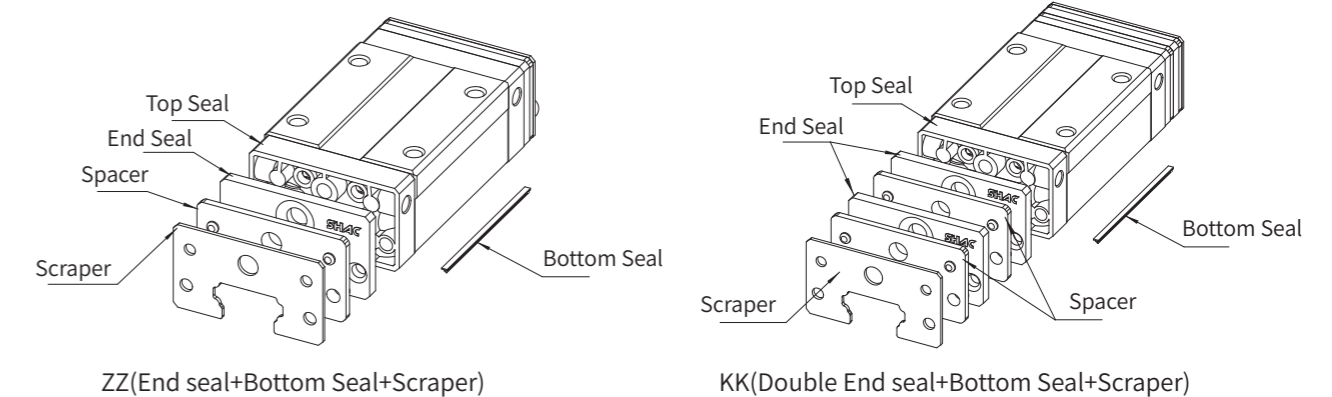

Figure 2-3-12

Figure 2-3-14

Dust prevention accessory instructions

When the slider moves back and forth, hard debris such as iron filings can enter the slider and damage the surface of the groove, reducing the accuracy and lifespan of the linear guide. Foreign objects such as dust and sawdust can accumulate in the ball path, causing problems such as ball bursting. In order to ensure its normal use, appropriate dust prevention measures must be taken.

Dust sheet and bottom dust strip

Dust sheets and dust strips can effectively prevent debris or dust from entering the interior of the slider.

Double layer dust-proof sheet

Double the dust prevention effect, even in more harsh processing environments, it can still have excellent dust prevention effect.

Table 2-3-10 Thickness of End seal

Specification	End seal thickness (mm)
QH15	2
QH20	2
QH25	2
QH30	3

Metal scraper

Thanks to the high temperature resistance and hardness of metals, they can effectively isolate high-temperature iron filings and large foreign particles.

Table 2-3-11 Thickness of Scrper

Model No.	Metal scraper thickness (mm)
GE15	1.5
GE20	1.5
GE25	1.5
GE30	1.5
GE35	1.5

Space

The stacking of dust-proof layers affects the fit between the dust-proof sheets and the guide rail, thereby increasing friction. Adding spacers between the dust-proof sheets can ensure preloading and more effectively prevent dust.

Table 2-3-12 Thickness of Space

Model No.	Thickness of single scrper (mm)
GE15SC	1.5
GE20SC	1.5
GE25SC	1.5
GE30SC	1.5
GE35SC	1.5

TOTAL LENGTH OF Block PER DUST CODE

Table 2-3-13

Specification	Total length of block (L) (mm)			
	Standard	ZZ	DD	KK
QH15C	62.2	68.2	69.2	75.2
QH20C	76.5	82.5	83.5	89.5
QH20H	94.5	100.5	101.5	107.5
QH25C	82.5	88.5	89.5	95.5
QH25H	104.5	110.5	111.5	117.5
QH30C	100	106	109	115
QH30H	123.5	129.5	132.5	138.5

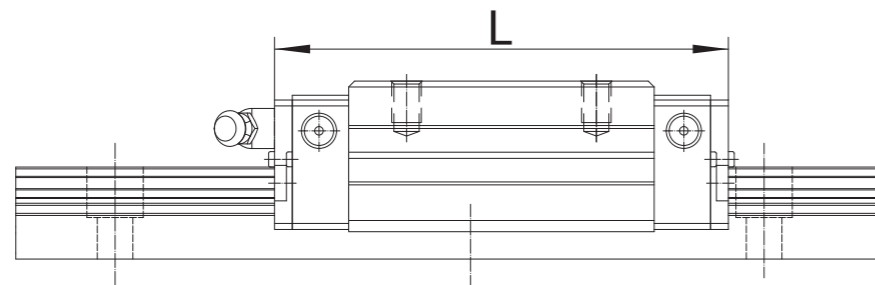

Figure 2-3-14

Friction Force

The resistance values in the following table are the maximum resistance of two end seal. Table 2-3-14 QH series dust sheet resistance values

Table 2-3-14

Specification	Resistance End seal (N) (kgf)
QH15	1.5 (0.15)
QH20	2.6 (0.26)
QH25	3.0 (0.3)
QH30	3.9 (0.4)

Note : 1kgf=9.81N

2-4-10 Allowable error of mounting surface

Due to the DF (45° - 45°)combined structure of the arc groove, it has the ability of automatic centering. Even if there is a certain deviation on the installation surface, it can automatically achieve a balanced state, maintain a stable, high-precision linear motion, and greatly improve the negative service life and accuracy of the guide rail.

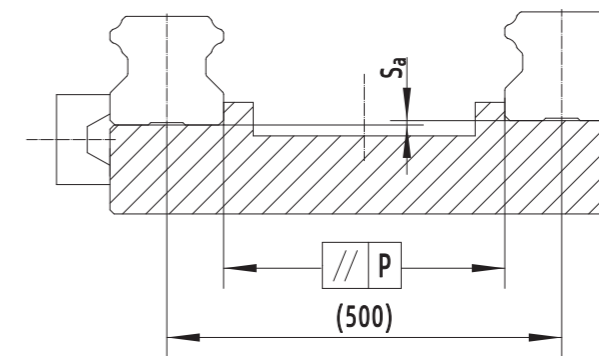

Figure 2-3-15

Table 2-3-15 Allowable parallelism error (P)

Unit: μm

Specification	Gread of preload		
	Z0	ZA	ZB
QH15	25	18	-
QH20	25	20	18
QH25	30	22	20
QH30	40	30	27

Table 2-3-16 Allowable upper and lower flatness error (S_a)

Unit: μm

Specification	Gread of preload		
	Z0	ZA	ZB
GE15	130	85	-
GE20	130	85	50
GE25	130	85	70
GE30	170	110	90

Note: The allowable value is directly proportional to the distance between two guide rails

2-4-11 Precautions for installation

(1) Precautions for installation

Height and chamfer of bearing surface

When installing the linear guide rail, pay attention to whether the size of the bearing surface is appropriate. For example, excessive chamfer will cause the guide rail and the bearing surface unable to be completely contacted,

It is easy to cause poor accuracy of linear guide rail. However, if the bearing surface is too high, it will conflict with the bottom height of the sliding block, so it cannot be installed.

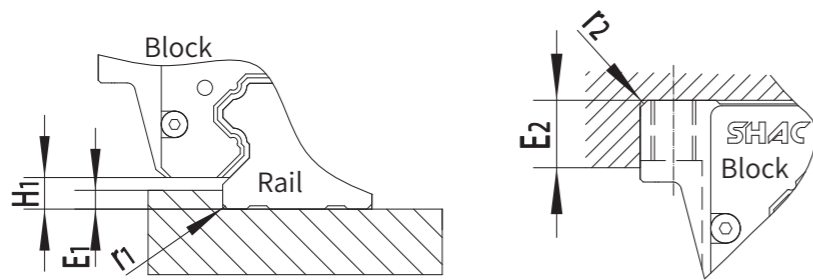

Figure 2-3-15

Table 2-3-17 Height of bearing surface and chamfer

Specification	Maximum guide rail end r_1 (mm)	Max. slide end Radius of fillet r_2 (mm)	Guide rail end bearing Height of abutting surface E_1 (mm)	Slide end bearing Height of abutting surface E_2 (mm)	Clear height of slide block H_1 (mm)	Chamfer dimensions for linear guide
						A/B
QH15	0.5	0.5	3.0	4.0	4.0	-
QH20	0.5	0.5	3.5	5.0	4.6	-
QH25	1.0	1.0	5.0	5.0	5.5	-
QH30	1.0	1.0	5.0	5.0	6.0	-

(2) Specification and torsion of guide rail mounting screw

The locking force of the mounting screws of the linear guide rail directly affects the service life and accuracy of the guide rail. Therefore, it is important to use a torque wrench to lock each screw with an appropriate torque value.

Table 2-3-17 Torque Values

Specification	Screw Size	Torque value N-cm (kgf-cm)		
		Iron parts	Casting	Aluminium alloy
QH15	M3×0.5P×16L	186 (19)	127 (13)	98 (10)
	M4×0.7P×16L	392 (40)	274 (28)	206 (20)
QH20	M5×0.8P×16L	883 (90)	588 (60)	441 (50)
QH25	M6×1P×20L	1373 (140)	921 (100)	686 (70)
QH30	M6×1P×20L	1373 (140)	921 (100)	686 (70)
	M8×1.25P×25L	3041 (310)	2010 (206)	1470 (150)

Note : 1kg = 9.81N

QH Series - Silent Heavy Duty Ball Linear Guide (injection structure type)

(1) QHH-CA / QHH-HA

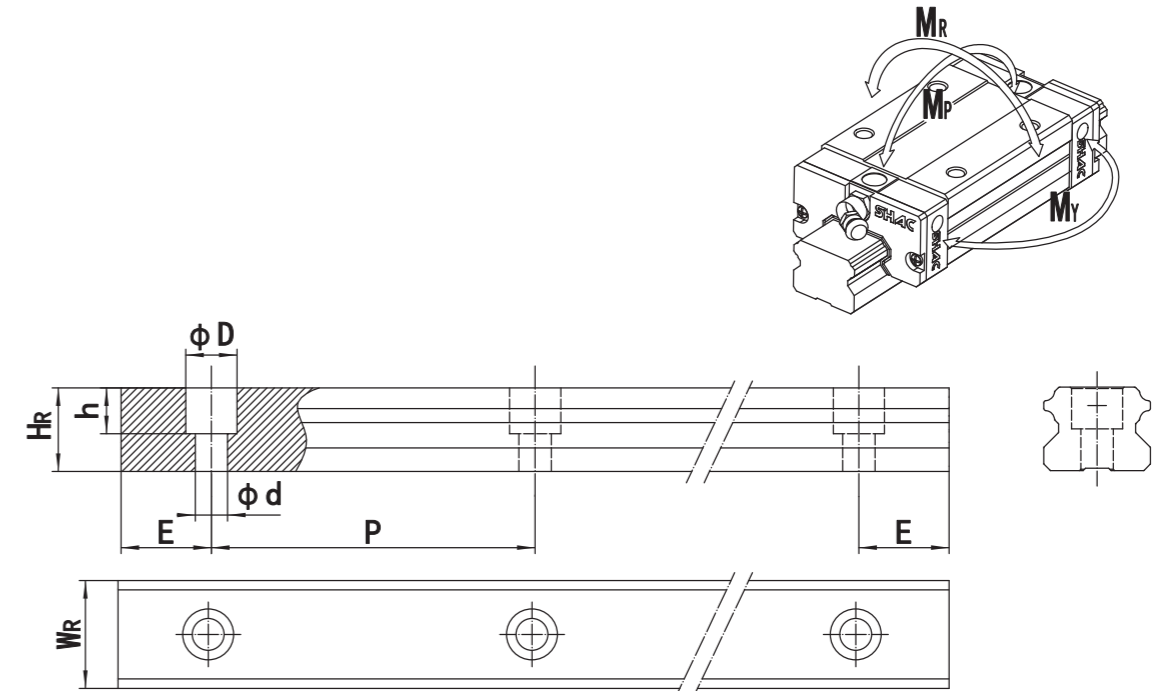
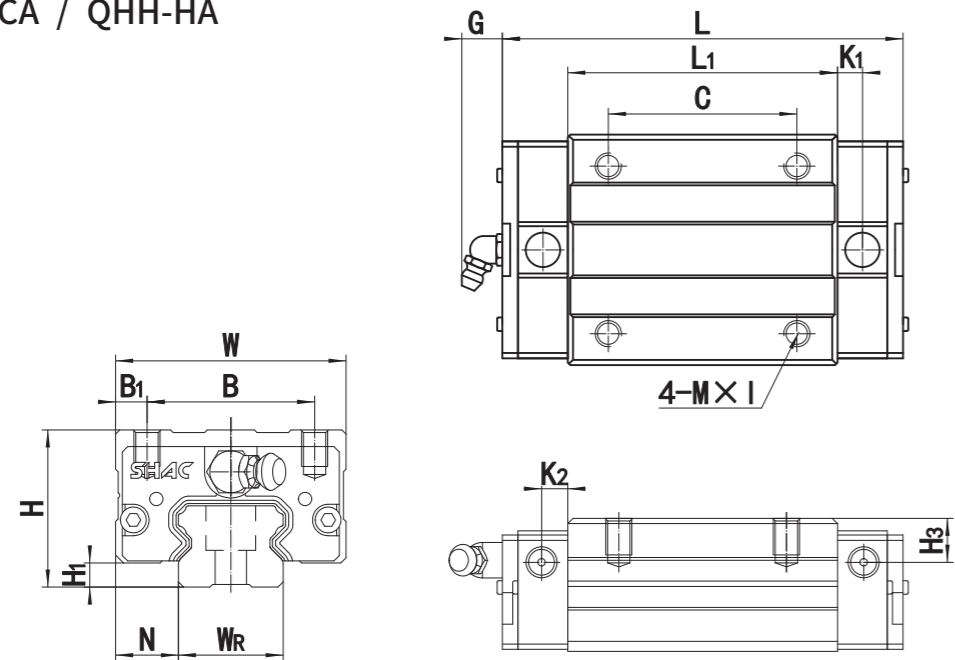

Model No.	Dimensions of Assembly (mm)			Dimensions of Block (mm)												
	H	H ₁	N	W	B	B ₁	C	L ₁	L	K ₁	K ₂	G	M*L	T	H ₂	H ₃
★ QHH15CA	28	3.2	9.5	34	26	4	26	39.8	62.2	3.5	3.5	5.5	M4×7	6	9.5	9
QHH15CA	28	3.2	9.5	34	26	4	26	39.8	62.2	3.5	3.5	5.5	M4×7	6	9.5	9
QHH20CA	30	4.6	12	44	32	6	36	51.5	76.5	4.75	5	12	M5×7	8	8	8.5
QHH20HA							50	69.5	94.5							
QHH25CA	40	4.5	12.5	48	35	6.5	35	59.5	82.5	4.75	5	12	M6×8	8	13	13
QHH25HA							50	81.5	104.5							
★ QHH30CA	45	7	16	60	40	10	40	70	98	6	5	12	M8×10	8.5	11	11
QHH30HA							60	93.5	121.5							
QHH30CA	45	7	16	60	40	10	40	70	98	6	5	12	M8×10	8.5	11	11
QHH30HA							60	93.5	121.5							

Note : 1KN=100kgf
Models marked with ★ feature small mounting holes. Please confirm with sales before placing your order.

Model No.	Dimensions of Rail(mm)							Mounting Boit for Rail (mm)	Basic Dynamic load Rating C (KN)	Basic Static load Rating C0 (KN)	Static Rated Monent			Weight	
	W _R	H _R	D	h	d	P	E				M _R KN—m	M _P KN—m	M _V KN—m	Block kg	Rail kg/m
★ GE15	15	12.5	6	4.5	3.5	60	20	M3×16	11.96	14.46	0.08	0.06	0.06	0.21	1.26
GE15U	15	12.5	7.5	5.3	4.5	60	20	M4×16	11.96	14.46	0.08	0.06	0.06	0.21	1.26
GE20	20	15.5	9.5	8.5	6	60	20	M5×16	17.46	21.59	0.22	0.15	0.15	0.32	2.09
									21.14	28.33	0.28	0.25	0.25	0.4	
GE25	23	18	11	9	7	60	20	M6×20	25.65	29.52	0.35	0.25	0.25	0.55	2.69
									32.88	42.17	0.48	0.42	0.42	0.72	
★ GE30	28	23	11	9	7	80	20	M6×25	42.17	45.22	0.52	0.45	0.45	0.9	4.26
									52.09	62.13	0.8	0.85	0.85	1.18	
GE30U	28	23	14	12	9	80	20	M8×25	42.17	45.22	0.52	0.45	0.45	0.9	4.26
									52.09	62.13	0.8	0.85	0.85	1.18	

Note : 1kgf = 9.81N

QH Series - Silent Heavy Duty Ball Linear Guide (injection structure type)

(2) QHW-CA / QHW-HA

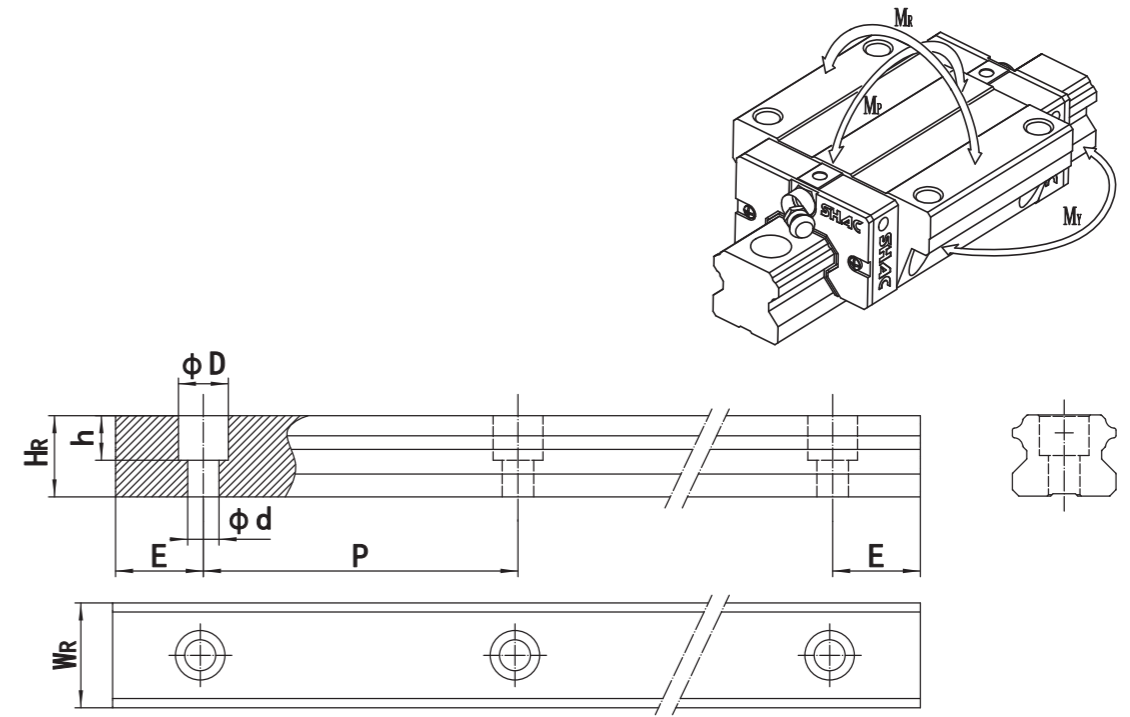
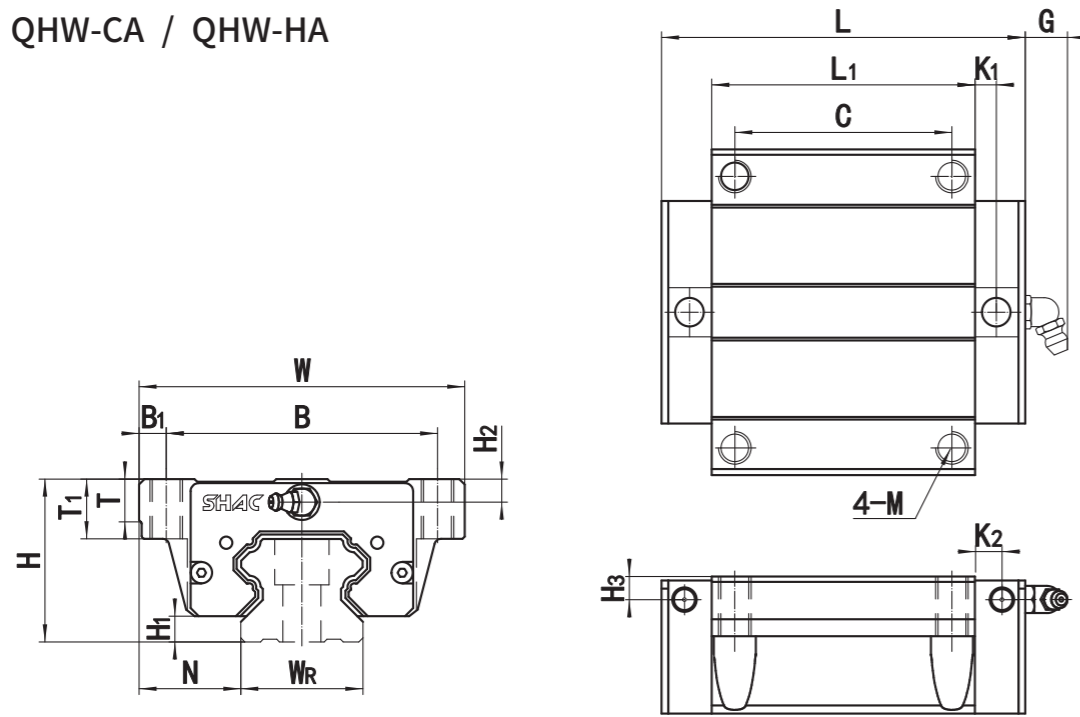

Model No.	Dimensions of Assembly (mm)			Dimensions of Block (mm)														
	H	H ₁	N	W	B	B ₁	C	L ₁	L	K ₁	K ₂	G	M	T	T ₁	H ₂	H ₃	
★ QHW15CA	24	3.2	16	47	38	4.5	30	39.8	62.2	3.35	4.75	5.5	M5	6	7	5.5	5.5	
QHW15CA	24	3.2	16	47	38	4.5	30	39.8	62.2	3.35	4.75	5.5	M5	6	7	5.5	5.5	
QHW20CA	30	4.6	21.5	63	53	5	40	51.5	76.5	4.75	5	12	M6	8	9	8	8	
QHW20HA								69.5	94.5									
QHW25CA	36	4.5	23.5	70	57	6.5	45	59.5	82.5	4.75	5	12	M8	8	10	9	9	
QHW25HA								81.5	104.5									
★ QHW30CA	42	7	31	90	72	9	52	70	98	6	5	12	M10	8.5	10	8	8	
QHW30HA								93.5	121.5									
QHW30CA	42	7	31	90	72	9	52	70	98	6	5	12	M10	8.5	10	8	8	
QHW30HA								93.5	121.5									

Note : 1KN=100kgf
Models marked with ★ feature small mounting holes. Please confirm with sales before placing your order.

Model No.	Dimensions of Rail(mm)						Mounting Boit for Rail (mm)	Basic Dynamic load Rating C (KN)	Basic Static load Rating C0 (KN)	Static Rated Monent			Weight	
	W _R	H _R	D	h	d	P				M _R KN-m	M _P KN-m	M _V KN-m	Block kg	Rail kg/m
★ GE15	15	12.5	6	4.5	3.5	60	M3×16	11.96	14.46	0.08	0.06	0.06	0.21	1.26
GE15U	15	12.5	7.5	5.3	4.5	60	M4×16	11.96	14.46	0.08	0.06	0.06	0.21	1.26
GE20	20	15.5	9.5	8.5	6	60	M5×16	17.46	21.59	0.22	0.15	0.15	0.32	2.09
								21.14	28.33	0.28	0.25	0.25	0.4	
GE25	23	18	11	9	7	60	M6×20	25.65	29.52	0.35	0.25	0.25	0.55	2.69
								32.88	42.17	0.48	0.42	0.42	0.72	
★ GE30	28	23	11	9	7	80	M6×25	42.17	45.22	0.52	0.45	0.45	0.9	4.26
								52.09	62.13	0.8	0.85	0.85	1.18	
GE30U	28	23	14	12	9	80	M8×25	42.17	45.22	0.52	0.45	0.45	0.9	4.26
								52.09	62.13	0.8	0.85	0.85	1.18	

Note : 1kgf = 9.81N

QH Series - Silent Heavy Duty Ball Linear Guide (injection structure type)

(3) QHW-CB / QHW-HB

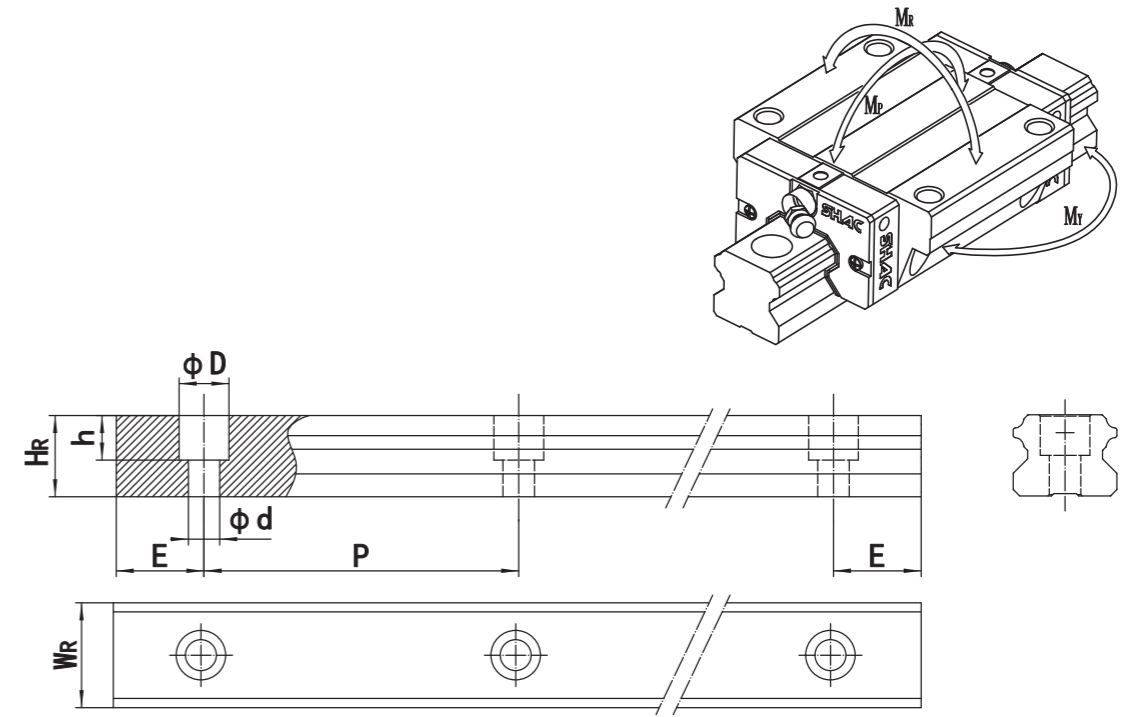
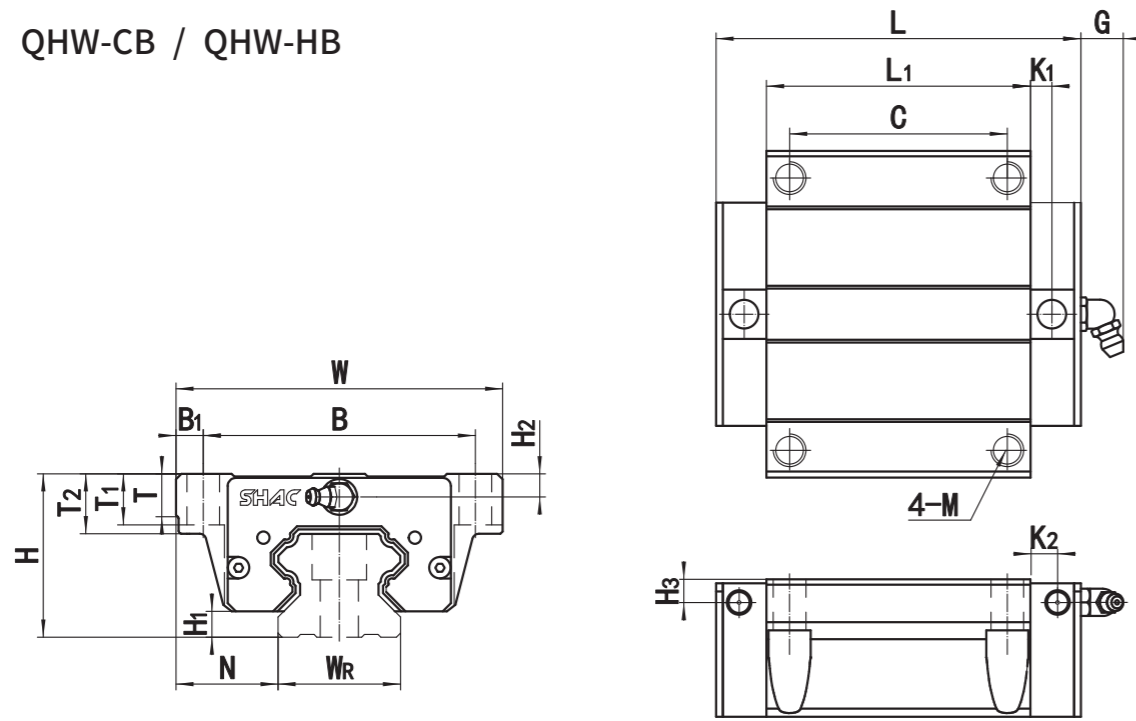

Model No.	Dimensions of Assembly (mm)			Dimensions of Block (mm)														
	H	H ₁	N	W	B	B ₁	C	L ₁	L	K ₁	K ₂	G	M	T	T ₁	T ₂	H ₂	H ₃
★ QHW15CB	24	3.2	16	47	38	4.5	30	39.8	62.2	3.35	4.75	5.5	φ4.5	6	7	8.9	5.5	5
QHW15CB	24	3.2	16	47	38	4.5	30	39.8	62.2	3.35	4.75	5.5	φ4.5	6	7	8.9	5.5	5
QHW20CB	30	4.6	21.5	63	53	5	40	51.5	76.5	4.75	5	12	φ6	8	9	10	8	8.5
QHW20HB								69.5	94.5									
QHW25CB	36	4.5	23.5	70	57	6.5	45	59.5	82.5	4.75	5	12	φ7	8	10	14	9	9
QHW25HB								81.5	104.5									
★ QHW30CB	42	7	31	90	72	9	52	70	98	6	5	12	φ9	8.5	10	16	8	8
QHW30HB								93.5	121.5									
QHW30CB	42	7	31	90	72	9	52	70	98	6	5	12	φ9	8.5	10	16	8	8
QHW30HB								93.5	121.5									

Note : 1KN=100kgf
Models marked with ★ feature small mounting holes. Please confirm with sales before placing your order.

Model No.	Dimensions of Rail(mm)							Mounting Boit for Rail (mm)	Basic Dynamic load Rating C (KN)	Basic Static load Rating C0 (KN)	Static Rated Monent			Weight	
	W _R	H _R	D	h	d	P	E				M _R KN—m	M _P KN—m	M _Y KN—m	Block kg	Rail kg/m
★ GE15	15	12.5	6	4.5	3.5	60	20	M3×16	11.96	14.46	0.08	0.06	0.06	0.21	1.26
GE15U	15	12.5	7.5	5.3	4.5	60	20	M4×16	11.96	14.46	0.08	0.06	0.06	0.21	1.26
GE20	20	15.5	9.5	8.5	6	60	20	M5×16	17.46	21.59	0.22	0.15	0.15	0.32	2.09
									21.14	28.33	0.28	0.25	0.25	0.4	
GE25	23	18	11	9	7	60	20	M6×20	25.65	29.52	0.35	0.25	0.25	0.55	2.69
									32.88	42.17	0.48	0.42	0.42	0.72	
★ GE30	28	23	11	9	7	80	20	M6×25	42.17	45.22	0.52	0.45	0.45	0.9	4.26
									52.09	62.13	0.8	0.85	0.85	1.18	
GE30U	28	23	14	12	9	80	20	M8×25	42.17	45.22	0.52	0.45	0.45	0.9	4.26
									52.09	62.13	0.8	0.85	0.85	1.18	

Note : 1kgf = 9.81N

QH Series - Silent Heavy Duty Ball Linear Guide (injection structure type)

(4) QHW-CC / QHW-HC

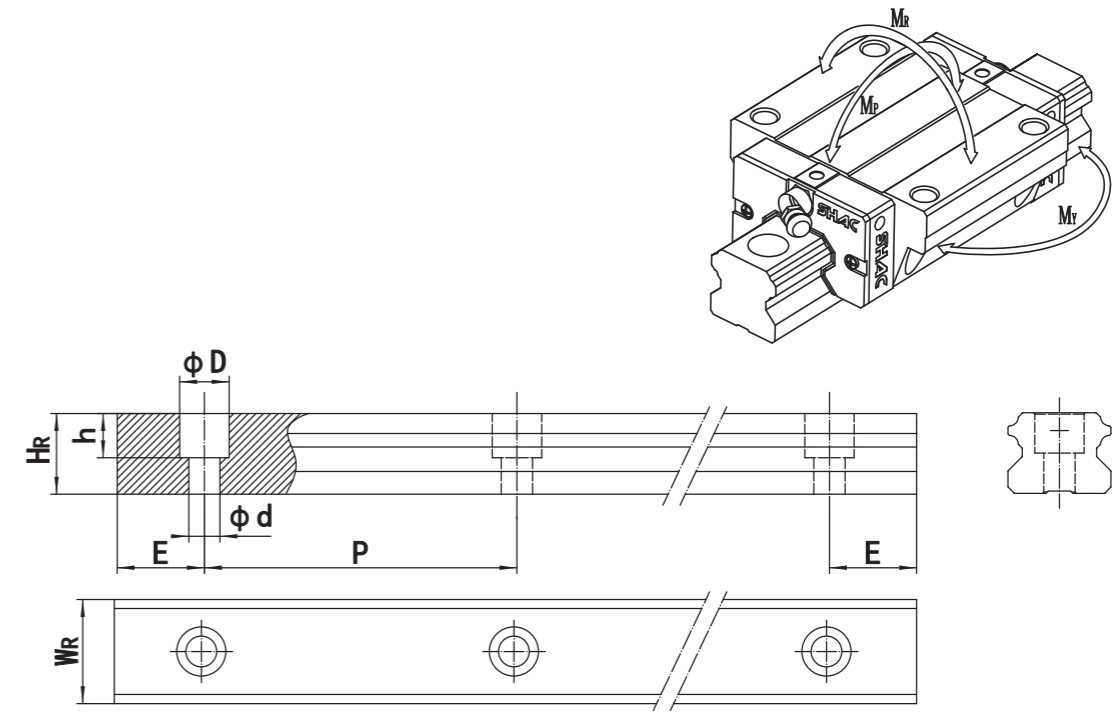
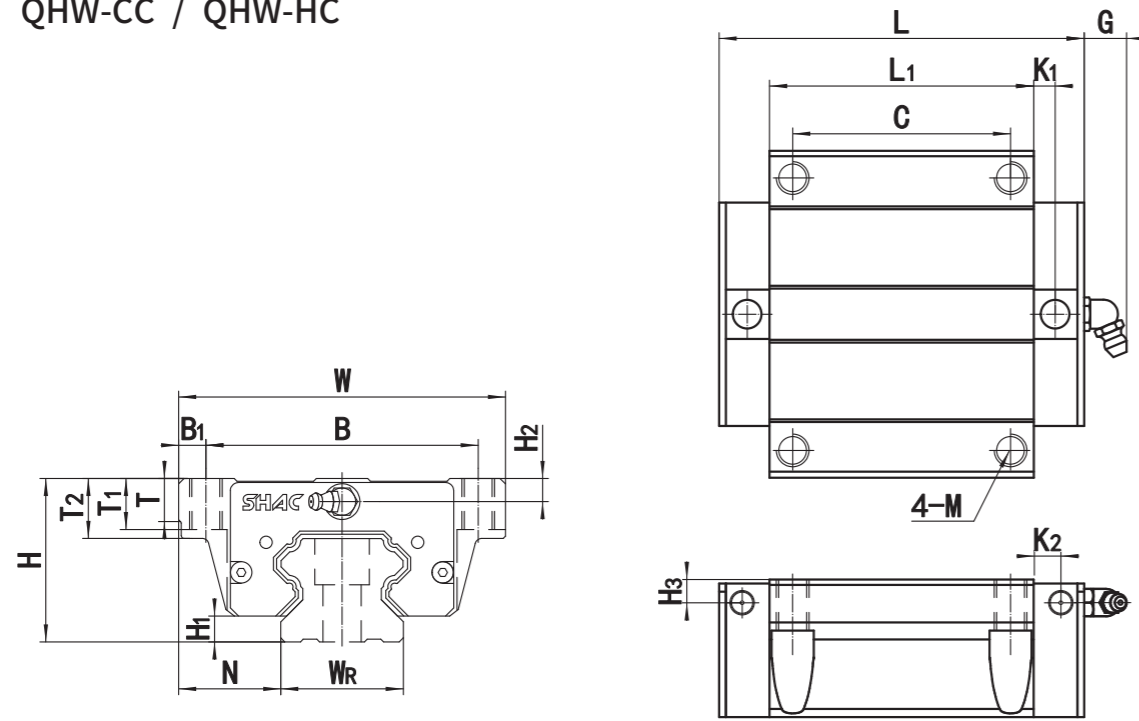

Model No.	Dimensions of Assembly (mm)			Dimensions of Block (mm)														
	H	H ₁	N	W	B	B ₁	C	L ₁	L	K ₁	K ₂	G	M	T	T ₁	T ₂	H ₂	H ₃
★ QHW15CC	24	3.2	16	47	38	4.5	30	39.8	62.2	3.35	4.75	5.5	M5	6	6.95	8.9	5.5	5
QHW15CC	24	3.2	16	47	38	4.5	30	39.8	62.2	3.35	4.75	5.5	M5	6	6.95	8.9	5.5	5
QHW20CC	30	4.6	21.5	63	53	5	40	51.5	76.5	4.75	5	12	M6	8	9	10	8	8.5
QHW20HC								69.5	94.5									
QHW25CC	36	4.5	23.5	70	57	6.5	45	59.5	82.5	4.75	5	12	M8	8	10	14	9	9
QHW25HC								81.5	104.5									
★ QHW30CC	42	7	31	90	72	9	52	70	98	6	5	12	M10	8.5	10	16	8	8
QHW30HC								93.5	121.5									
QHW30CC	42	7	31	90	72	9	52	70	98	6	5	12	M10	8.5	10	16	8	8
QHW30HC								93.5	121.5									

Note : 1KN=100kgf
Models marked with ★ feature small mounting holes. Please confirm with sales before placing your order.

Model No.	Dimensions of Rail(mm)							Mounting Boit for Rail (mm)	Basic Dynamic load Rating C (KN)	Basic Static load Rating C0 (KN)	Static Rated Monent			Weight	
	W _R	H _R	D	h	d	P	E				M _R KN—m	M _P KN—m	M _V KN—m	Block kg	Rail kg/m
★ GE15	15	12.5	6	4.5	3.5	60	20	M3×16	11.96	14.46	0.08	0.06	0.06	0.21	1.26
GE15U	15	12.5	7.5	5.3	4.5	60	20	M4×16	11.96	14.46	0.08	0.06	0.06	0.21	1.26
GE20	20	15.5	9.5	8.5	6	60	20	M5×16	17.46	21.59	0.22	0.15	0.15	0.32	2.09
									21.14	28.33	0.28	0.25	0.25	0.4	
GE25	23	18	11	9	7	60	20	M6×20	25.65	29.52	0.35	0.25	0.25	0.55	2.69
									32.88	42.17	0.48	0.42	0.42	0.72	
★ GE30	28	23	11	9	7	80	20	M6×25	42.17	45.22	0.52	0.45	0.45	0.9	4.26
									52.09	62.13	0.8	0.85	0.85	1.18	
GE30U	28	23	14	12	9	80	20	M8×25	42.17	45.22	0.52	0.45	0.45	0.9	4.26
									52.09	62.13	0.8	0.85	0.85	1.18	

Note : 1kgf = 9.81N

2-5 QE Series - Silent Low Assembly Ball Linear Guide

QE series chain belt silent ball linear guide rail is still designed with four-row single-arc groove contact, which improves the competitive advantage of the product and provides silent chain belt for each row of steel balls. It can prevent friction between steel balls and effectively reduce the noise caused by auxiliary operation of guide rail.

It can make the steel ball more stable when entering and leaving the load area and load area, greatly improving the stability and smoothness of transportation. Particularly suitable for High-tech industry with high speed, quiet and low dust emission.

Product Structure

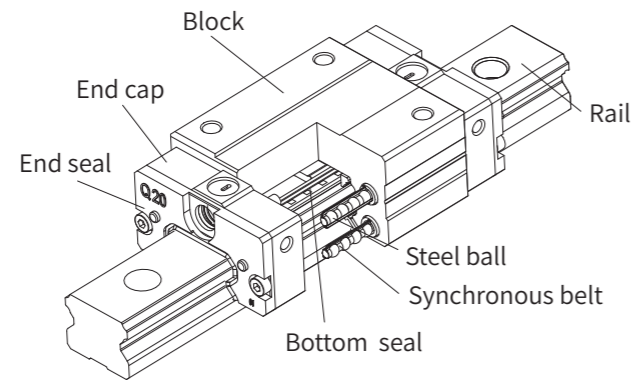
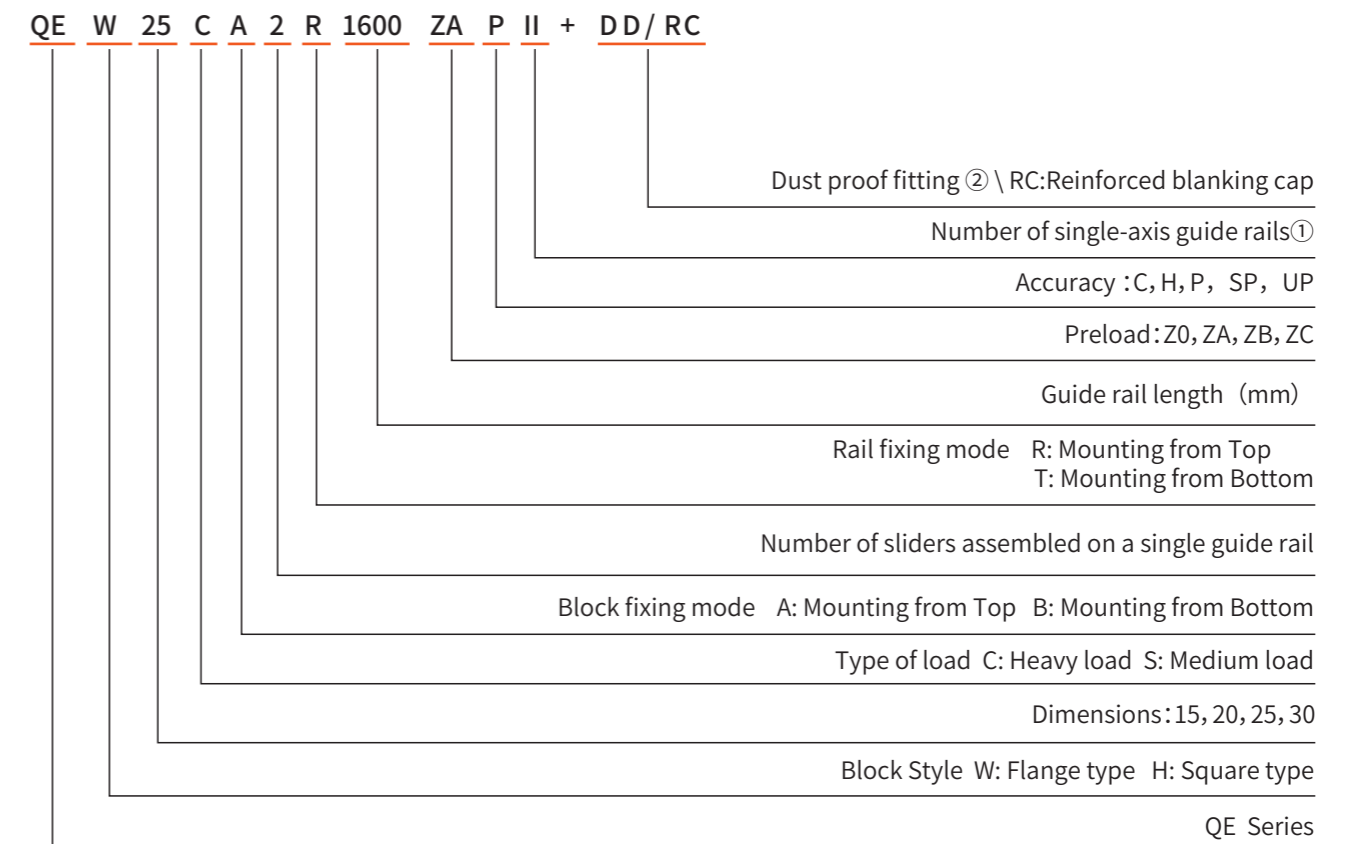

Figure 2-4-1

- ◎Rolling cycle system: slider guide rail, end cover, steel ball and steel ball retainer
- ◎Lubrication system: nozzle, oil pipe joint, end cover, steel ball, steel ball retainer
- ◎Dust prevention system: dust strip, bottom dust seal dust strip, guide rail cap, metal scraper

2-5-1 Product model of non-interchangeable linear guide rail



Note:

1. The number of single-axis guide rails is not written if only support guide rails are used, Two are marked as II, three are marked as III, and so on.
2. If there is no mark in the dust proof accessories, the standard dust proof accessories shall be provided with dust strip.
ZZ: dust strip, dust strip and metal scraper.
KK is double dust strip, dust strip and metal scraper.
DD DUAL DUAL DUST FINS WITH DUST STRIPS.

2-5-2 Product model of interchangeable linear guide rail

Product Structure

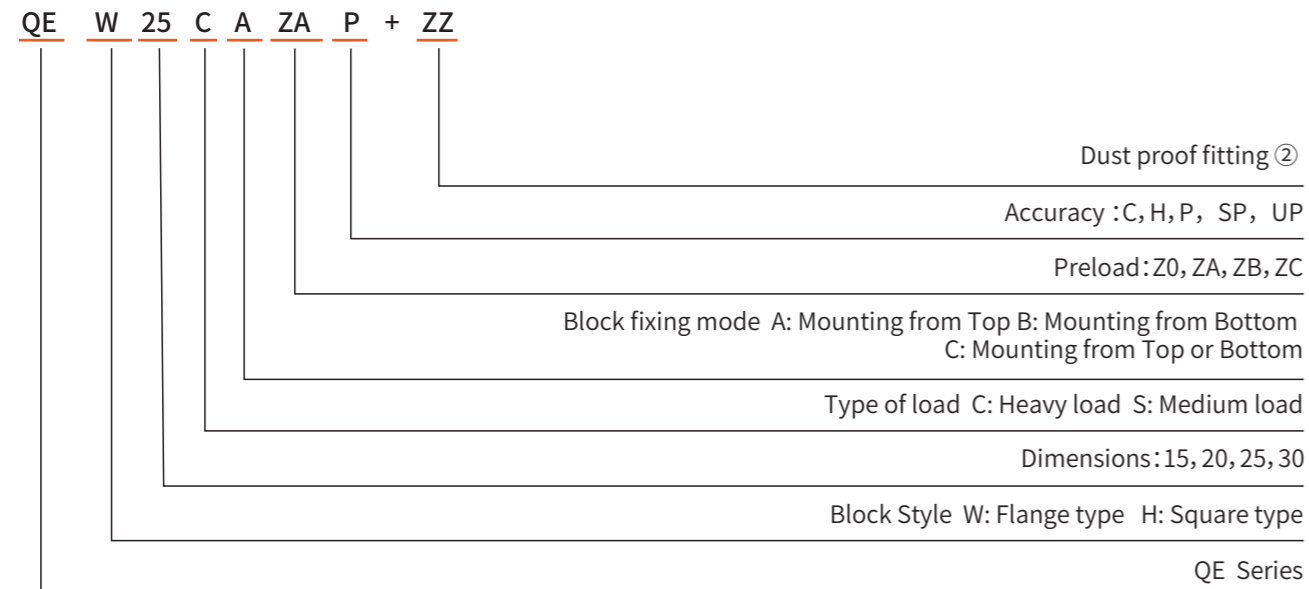

Product model of interchangeable guide rail

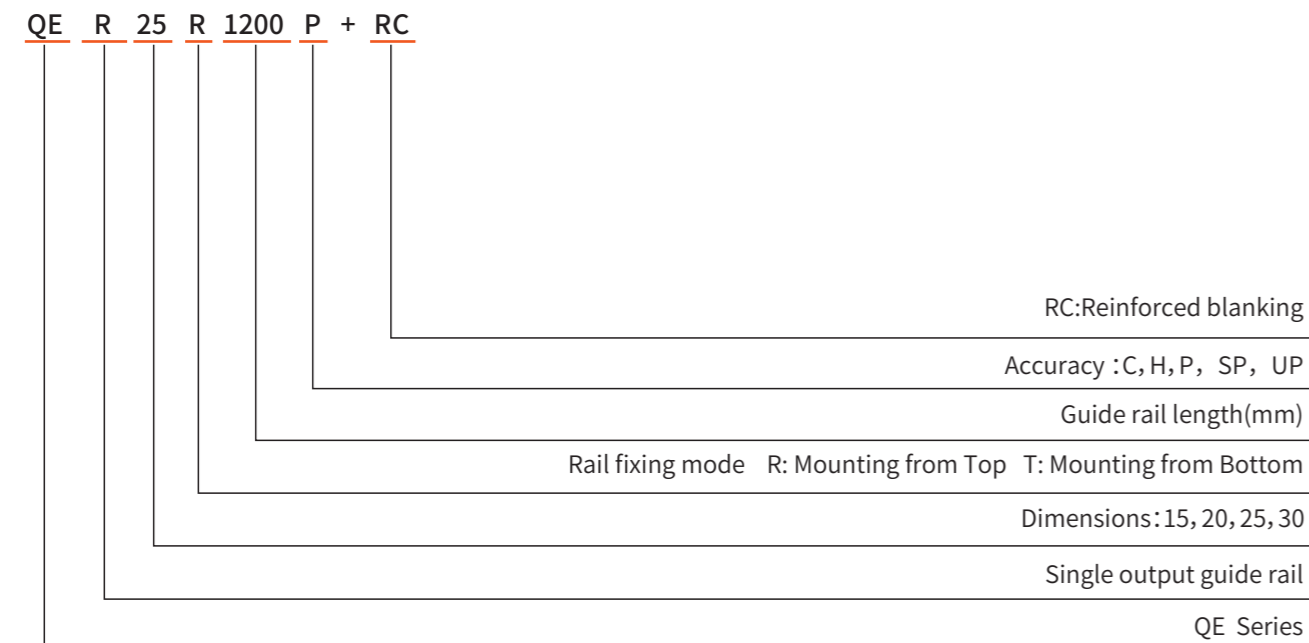

2-5-3 QE Series - Silent Low Assembly Ball Linear Guide

(1) block type

SHAC provides two types of linear guide rails, i.e. flanged guide rail and square guide rail. The overall combination height of flanged guide rail is lower and the width is wider. The flange part is provided with machined through screw holes, which can meet the installation requirements of lower lock type

Table 2-4-1 Type Block Type

Style	Specification	SHAPE	Height dimension	Guide rail length	Equipment suitable for application
Square	QEH-SA QEH-CA		24	100	<ul style="list-style-type: none"> Precision measuring instrument. Automation device.
			↓	↓	
Flange	QEW-SA QEW-CA		24	100	<ul style="list-style-type: none"> High-speed transportation equipment. Semiconductor equipment
			↓	↓	
	QEW-SB QEW-CB		24	100	
			↓	↓	
	QEW-SC QEW-CC		24	100	
			↓	↓	
		48	6000		

(2) Guideways Type

QE series products share the guide rail with GE series products. In addition to the guide rail shared by Yiban QE series products and GE series and the locking screw hole guide rail, the locking screw hole guide rail is also provided for easy installation and use.

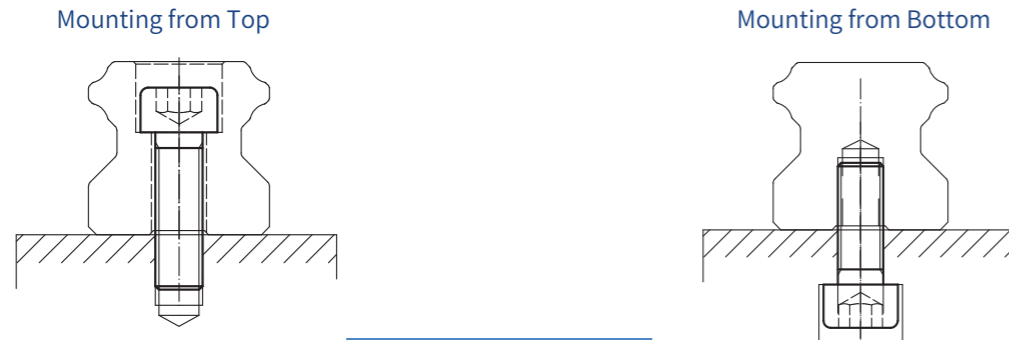

Figure 2-4-2

Grade of Accuracy

The precision of QE series linear guide rail can be divided into five levels: ordinary level, advanced level, precision level, ultra-precision level and ultra-high precision level. Users can select products of corresponding level according to equipment requirements.

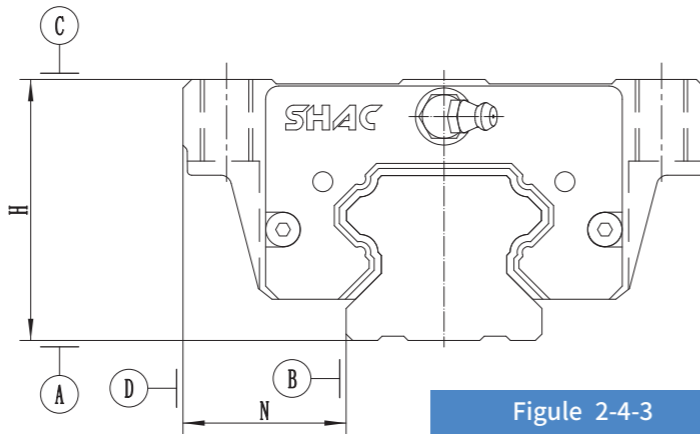

Figure 2-4-3

2-5-4 Precision of non-interchangeable linear guide rail

Table 2-4-2 Assembly accuracy table

Unit : mm

Model No.	QE-15, 20				
	Ultra-Precision Level (UP)	Super-Precision Level (SP)	Precision Level (P)	High Level (H)	Ordinary Level (C)
Allowable dimension error of height H	0 -0.008	0 -0.015	0 -0.03	±0.03	±0.1
Allowable error of width N	0 -0.008	0 -0.015	0 -0.03	±0.03	±0.1
Mutual error of paired width H	0.003	0.004	0.006	0.01	0.02
Allowable error of paired width N	0.003	0.004	0.006	0.01	0.02
Traveling parallelism of slide block C to surface A of guide rail	Travel parallelism (see Table 2-4-7)				
Traveling parallelism of slide block D to surface B of guide rail					

Table 2-4-3 Assembly accuracy table

Unit : mm

Model No.	QE-25, 30				
	Ultra-Precision Level (UP)	Super-Precision Level (SP)	Precision Level (P)	High Level (H)	Ordinary Level (C)
Allowable dimension error of height H	0 -0.01	0 -0.02	0 -0.04	±0.04	±0.1
Allowable error of width N	0 -0.01	0 -0.02	0 -0.04	±0.04	±0.1
Mutual error of paired width H	0.003	0.005	0.007	0.015	0.02
Allowable error of paired width N	0.003	0.005	0.007	0.015	0.03
Traveling parallelism of slide block C to surface A of guide rail	Travel parallelism (see Table 2-4-7)				
Traveling parallelism of slide block D to surface B of guide rail					

2-5-5 Precision of interchangeable linear guide rail

Table 2-4-4 Single Output Accuracy Table

Unit : mm

Model No.	QE-15, 20		
	Precision Level (P)	High Level (H)	Ordinary Level (C)
Allowable dimension error of height H	±0.015	±0.03	±0.1
Allowable error of width N	±0.015	±0.03	±0.1
Mutual error of paired width H	0.006	0.01	0.02
Allowable error of paired width N	0.006	0.01	0.02
Traveling parallelism of slide block C to surface A of guide rail	Travel parallelism (see Table 2-4-7)		
Traveling parallelism of slide block D to surface B of guide rail			

Table 2-4-5 Single Output Accuracy Table

Unit : mm

Model No.	QE-25, 30, 35		
	Precision Level (P)	High Level (H)	Ordinary Level (C)
Allowable dimension error of height H	±0.02	±0.04	±0.1
Allowable error of width N	±0.02	±0.04	±0.1
Mutual error of paired width H	0.007	0.015	0.02
Allowable error of paired width N	0.007	0.015	0.03
Traveling parallelism of slide block C to surface A of guide rail	Travel parallelism (see Table 2-4-7)		
Traveling parallelism of slide block D to surface B of guide rail			

2-5-6 Traveling parallel precision

Table 2-4-6

Unit : mm

Length of Rail (mm)	Gread of Precision (μm)				
	UP	SP	P	H	C
~100	2	2	3	7	12
100~200	2	2	4	9	14
200~300	2	3	5	10	15
300~500	2	3	6	12	17
500~700	2	4	7	13	20
700~900	3	5	8	15	22
900~1100	3	6	9	16	24
1100~1500	4	7	11	18	26
1500~1900	4	8	13	20	28
1900~2500	5	10	15	22	31
2500~3100	6	11	18	25	33
3100~3600	7	14	20	27	36
3600~4000	7	15	21	28	37

Preload

The so-called preloading is to increase the diameter of the steel ball to produce negative pressure between the steel ball and the channel. Clearances, pre-applied loads internally. Clearance is not only eliminated by assembly with preload. It can also improve the rigidity and precision of the sliding block.

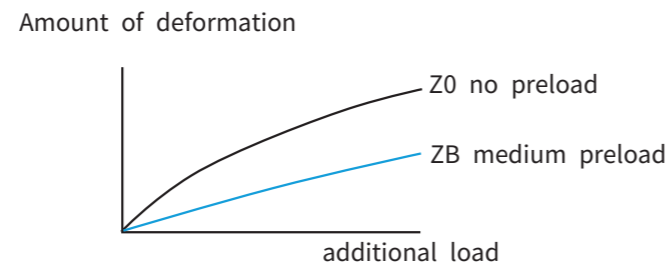

Figure 2-4-4

2-5-7 Grade of Preload

QE series linear guide rail has three kinds of preloading standards for selection. Appropriate preloading can improve the accuracy and rigidity. Excessive preloading has a certain impact on the service life. Therefore, according to the model, the purpose is to select the proper preloading. For example, it is recommended to select the lighter preloading for small models.

Table 2-4-7

Degree of preload	Code	Preload	Service conditions
No preload	Z0	0~0.02C	Fixed load direction, small impact and low precision requirements
Light preload	ZA	0.03C~0.05C	Light duty and high accuracy required
Medium preload	ZB	0.06C~0.08C	High rigidity, vibration and impact environment
Heavy preload	ZC	0.08C~0.12C	It requires higher rigidity and has a service environment with large vibration and impact
Assembly mode	Non-interchangeable track (single output)		Non-interchangeable track (single output)
Grade of preload	Z0、ZA		Z0、ZA、ZB

Note: C in the pre-pressure is the dynamic rated load

2-5-8 Lubrication frequency

Dust proof fitting and code

Generally, the standard dustproof is used in the operating environment without special requirements. If the following dustproof accessories are required, please mark the code behind the product model.

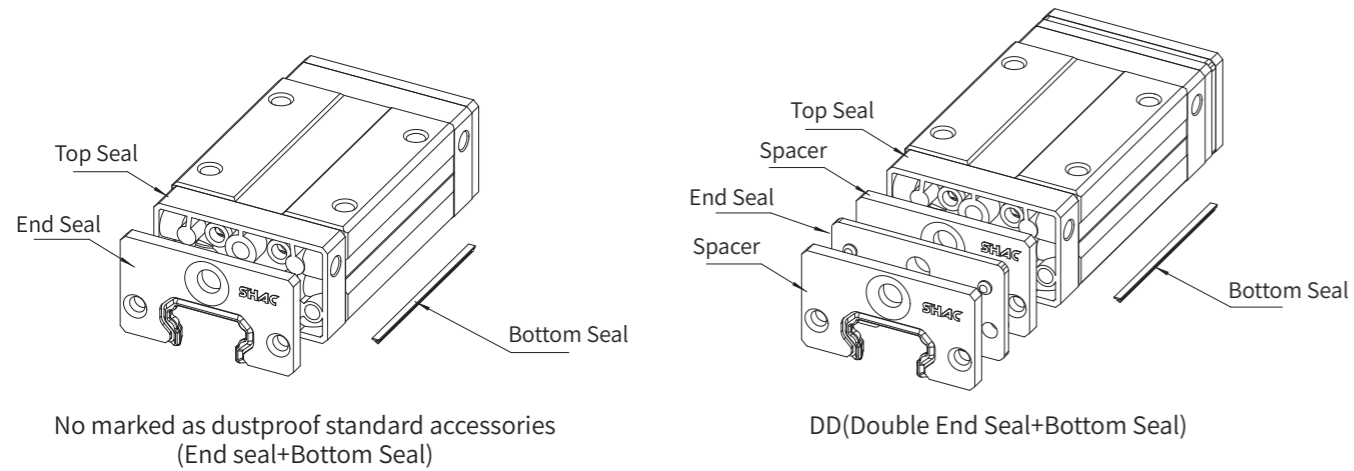

Figure 2-4-5

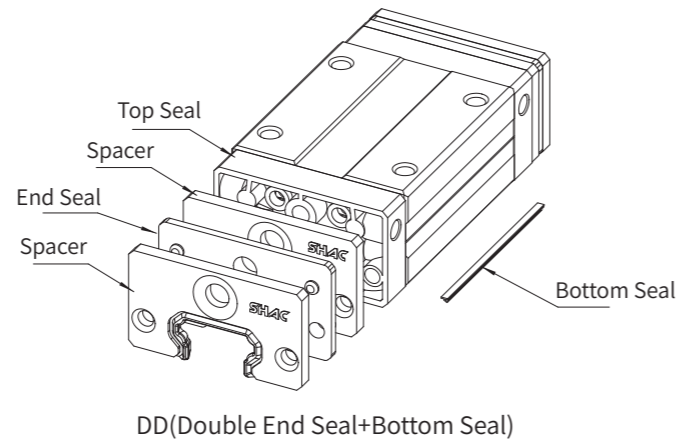

Figure 2-4-6

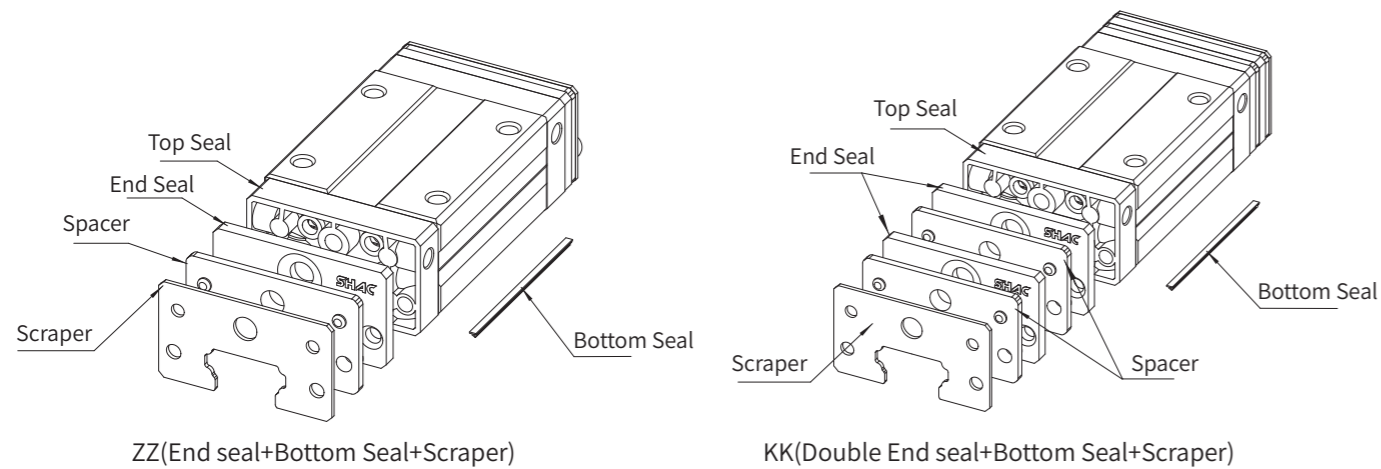

Figure 2-4-7

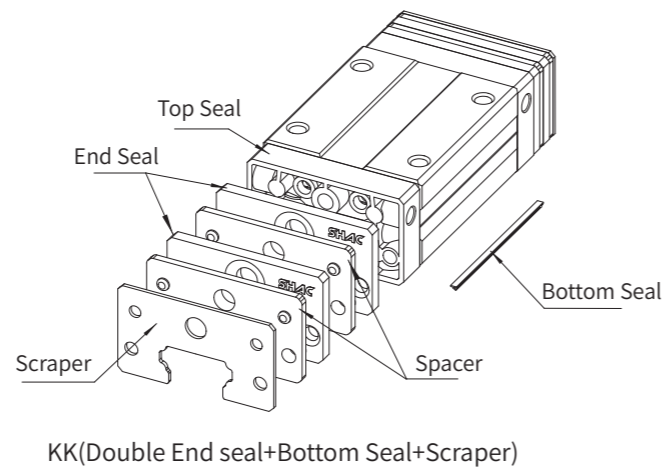

Figure 2-4-8

Dust-proof fitting description

When the slider moves back and forth, scrap iron and other debris will enter the slider to damage the surface of the channel and reduce the service life of the linear guide rail. Dust, wood chips and other foreign matters will accumulate in the channel and cause blockage. Proper dust prevention measures must be taken to ensure its service life.

End seal and bottom seal

The end seal and the bottom seal can effectively prevent debris or dust from entering the inside of the slider.

Metal scraper

Thanks to the high temperature resistance and high hardness of metal, it can effectively isolate high-temperature scrap iron and large foreign matters.

Space

Superimposed two dust sheets will affect the cooperation between guide rail and dust sheet, increase friction force, separate two dust sheets with grid piece, ensure real prepressing, reduce friction force and effectively prevent dust.

Double end seal

Double dustproof effect, even in worse processing environment, it can also have excellent dustproof effect.

Table 2-4-8 Thickness of end seal

specification	Thickness of end seal(mm)
QE15	2
QE20	2
QE25	2.5
QE30	2.5

Table 2-4-9 Thickness of single scraper

specification	Thickness of single scraper(mm)
QE15	1
QE20	1
QE25	1
QE30	1.5

Table 2-4-10 Thickness of Space

specification	Thickness of Space(mm)
QE15	1.5
QE20	1.5
QE25	1.5
QE30	1.5

TOTAL BLOCK LENGTH PER DUST CODE

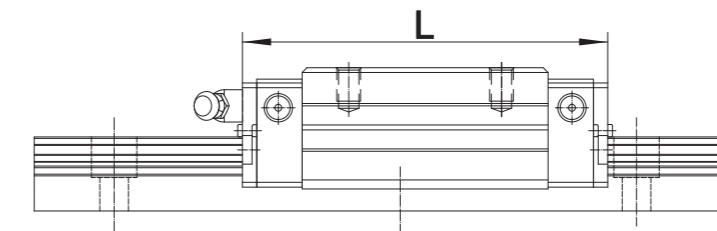

Figure 2-4-9

Table 2-4-11 TOTAL BLOCK LENGTH PER DUST CODE

Specification	Total block length (L) (mm)				Specification	Total block length (L) (mm)			
	Standard	ZZ	DD	KK		Standard	ZZ	DD	KK
QE15S	45.5	51.5	52.5	58.5	QE25S	60.5	66.5	67.5	73.5
QE15C	62.2	68.2	69.2	75.2	QE25C	82.5	88.5	89.5	95.5
QE20S	54	60	61	67	QE30S	71.5	77.5	80.5	86.5
QE20C	76.5	82.5	83.5	89.5	QE30C	100	106	109	115

Friction force

The resistance values in the following table are the maximum resistance of two end seal

Table 2-4-12 Resistance value of QE series dust cover

Table 2-4-12 Resistance value of dust

Specification	Resistance of end seal (N) (kgf)
QE15	1.5 (0.15)
QE20	2.6 (0.26)
QE25	3.00 (0.3)
QE30	3.9 (0.4)

Note : 1kg = 9.81N

2-5-9 Allowable error of mounting surface

Due to the DF (45° - 45°)combined structure of the arc groove, it has the ability of automatic centering. Even if there is a certain deviation on the installation surface, it can automatically achieve a balanced state, maintain a stable, high-precision linear motion, and greatly improve the negative service life and accuracy of the guide rail.

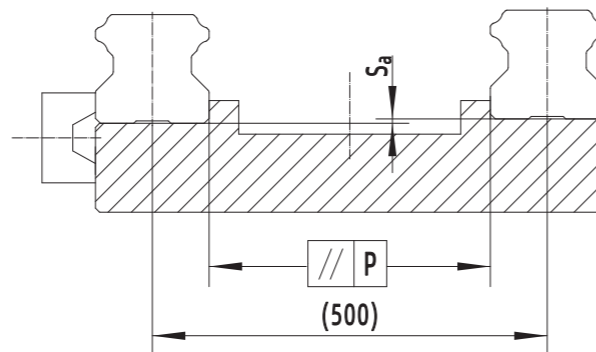

Figure 2-4-10

Table 2-4-13 Allowable parallelism error (P)

Unit: μm

Specification	Grade of preload		
	Z0	ZA	ZB
QE15	25	18	-
QE20	25	20	18
QE25	30	22	20
QE30	40	30	27

Table 2-4-14 Allowable upper and lower flatness error (S_a)

Unit: μm

Specification	Grade of preload		
	Z0	ZA	ZB
GE15	130	85	-
GE20	130	85	50
GE25	130	85	70
GE30	170	110	90

Note: The allowable value is directly proportional to the distance between two guide rails

2-5-10 Precautions for installation

(1) Precautions for installation

Height and chamfer of bearing surface

When installing the linear guide rail, pay attention to whether the size of the bearing surface is appropriate. For example, excessive chamfer will cause the guide rail and the bearing surface unable to be completely contacted,

It is easy to cause poor accuracy of linear guide rail. However, if the bearing surface is too high, it will conflict with the bottom height of the sliding block, so it cannot be installed.

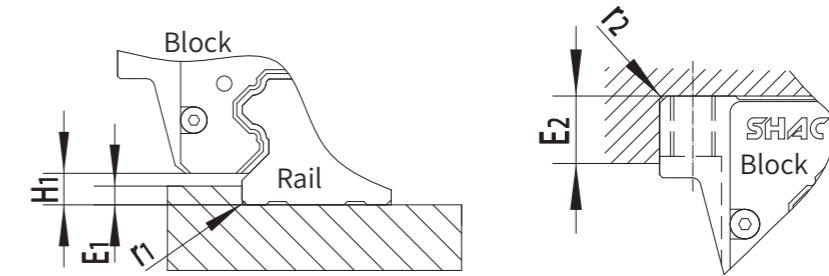

Figure 2-4-11

Table 2-4-15 Height of bearing surface and chamfer

Specification	Maximum guide rail end r_1 (mm)	Max. slide end Radius of fillet r_2 (mm)	Guide rail end bearing Height of abutting surface E_1 (mm)	Slide end bearing Height of abutting surface E_2 (mm)	Clear height of slide block H_1 (mm)	Chamfer dimensions for linear guide
						A/B
QE15	0.5	0.5	2.7	5.0	4.0	-
QE20	0.5	0.5	5.0	7.0	6.0	-
QE25	1.0	1.0	5.0	7.5	6.2	-
QE30	1.0	1.0	7.0	7.0	10.0	-

(2) Specification and torsion of guide rail mounting screw

The locking force of the mounting screws of the linear guide rail directly affects the service life and accuracy of the guide rail. Therefore, it is important to use a torque wrench to lock each screw with an appropriate torque value.

Table 2-4-16 Torque Values

Specification	Screw Size	Torque value N-cm (kgf-cm)		
		Iron parts	Casting	Aluminium alloy
QE15	M3×0.5P×16L	186 (19)	127 (13)	98 (10)
	M4×0.7P×16L	392 (40)	274 (28)	206 (20)
QE20	M5×0.8P×16L	883 (90)	588 (60)	441 (45)
QE25	M6×1P×20L	1373 (140)	921 (94)	686 (70)
QE30	M6×1P×25L	1373 (140)	921 (946)	686 (70)
	M8×1.25P×25L	3041 (310)	2010 (206)	1470 (150)

Note : 1kg = 9.81N

QE Series - Silent Low Assembly Ball Linear Guide (injection structure type)

(1) QEH-CA / QEH-SA

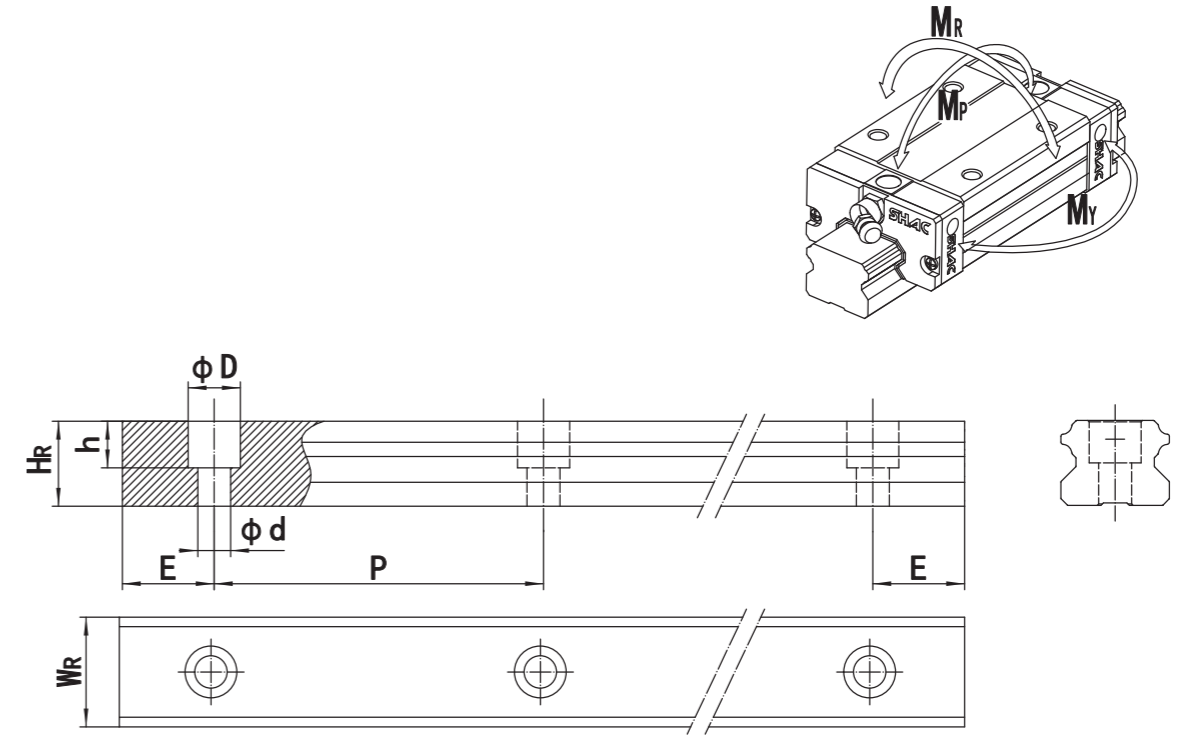
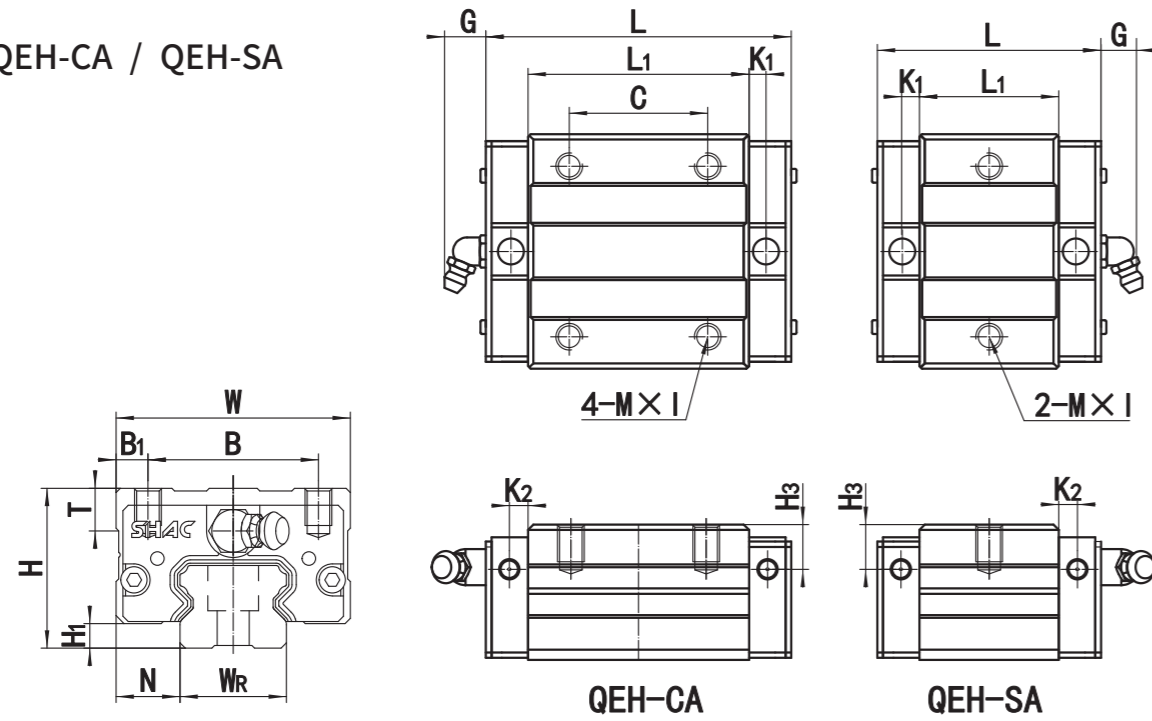

Model No.	Dimensions of Assembly (mm)			Dimensions of Block (mm)												
	H	H ₁	N	W	B	B ₁	C	L ₁	L	K ₁	K ₂	G	M*L	T	H ₂	H ₃
★ QEH15SA	24	3.2	9.5	34	26	4	-	23.1	45.5	3.5	3.5	5.5	M4×5	5	5.5	5
QEH15CA							26	39.8	62.2							
QEH15SA	24	3.2	9.5	34	26	4	-	23.1	45.5	3.5	3.5	5.5	M4×5	5	5.5	5
QEH15CA							26	39.8	62.2							
QEH20SA	28	4.6	11	42	32	5	-	29	54	4.75	5	12	M5×6	7	6	6.5
QEH20CA							32	51.5	76.5							
QEH25SA	33	4.5	12.5	48	35	6.5	-	37.5	60.5	4.75	5	12	M6×8	7.5	6	6
QEH25CA							35	59.5	82.5							
★ QEH30SA	42	7	16	60	40	10	-	41.5	69.5	6	5	12	M8×9	7	8	8
QEH30CA							40	70	98							
QEH30SA	42	7	16	60	40	10	-	41.5	69.5	6	5	12	M8×9	7	8	8
QEH30CA							40	70	98							

Note : 1KN=100kgf
Models marked with ★ feature small mounting holes. Please confirm with sales before placing your order.

Model No.	Dimensions of Rail(mm)							Mounting Boit for Rail (mm)	Basic Dynamic load Rating C (KN)	Basic Static load Rating C0 (KN)	Static Rated Monent			Weight	
	W _R	H _R	D	h	d	P	E				M _R KN-m	M _P KN-m	M _V KN-m	Block kg	Rail kg/m
★ GE15	15	12.5	6	4.5	3.5	60	20	M3×16	8.09	8.26	0.06	0.02	0.02	0.14	1.26
GE15U									11.96	14.46	0.11	0.08	0.08	0.25	
GE15U	15	12.5	7.5	5.3	4.5	60	20	M4×16	8.09	8.26	0.06	0.02	0.02	0.14	1.26
GE20									11.96	14.46	0.11	0.08	0.08	0.25	
GE20	20	15.5	9.5	8.5	6	60	20	M5×16	11.46	12.14	0.11	0.04	0.04	0.21	2.09
GE25									17.46	21.59	0.19	0.13	0.13	0.35	
GE25	23	18	11	9	7	60	20	M6×20	18.81	18.98	0.2	0.09	0.09	0.37	2.69
GE30									25.65	29.52	0.35	0.27	0.27	0.65	
★ GE30	28	23	11	9	7	80	20	M6×25	24.88	25.96	0.36	0.15	0.15	0.64	4.26
GE30U									36.54	45.12	0.35	0.45	0.45	1.09	
GE30U	28	23	14	12	9	80	20	M8×25	24.88	25.96	0.36	0.15	0.15	0.64	4.26
GE30U									36.54	45.12	0.35	0.45	0.45	1.09	

Note : 1kgf = 9.81N

QE Series - Silent Low Assembly Ball Linear Guide (injection structure type)

(2) QEW-SA / QEW-CA

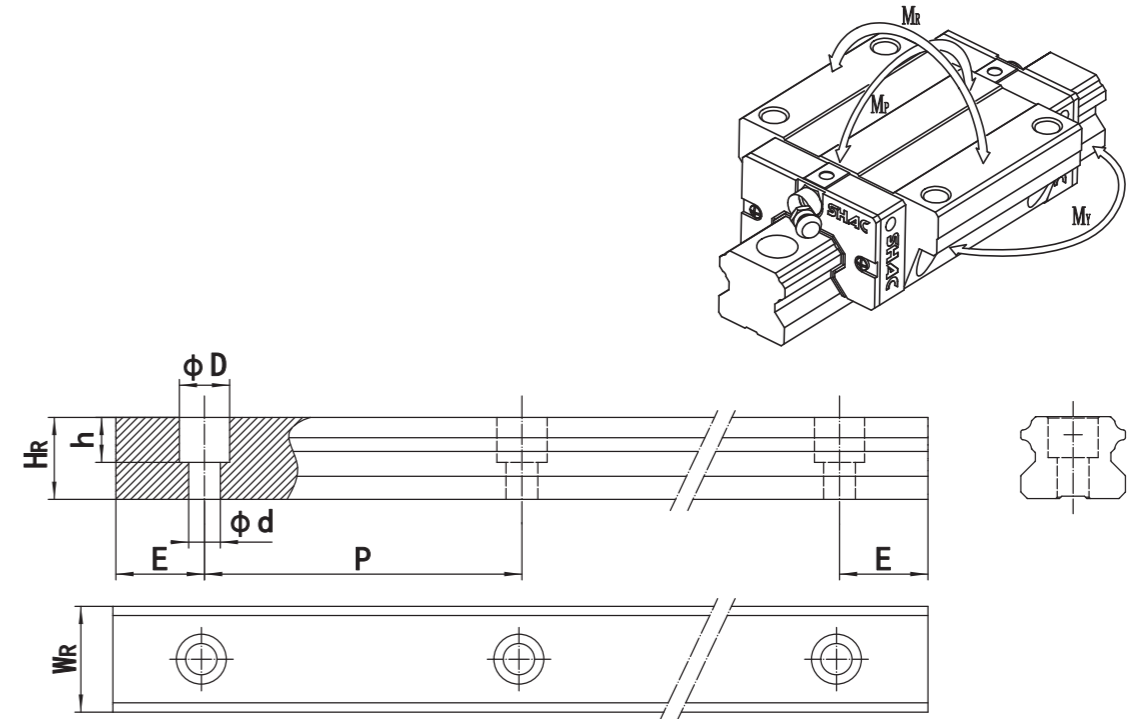
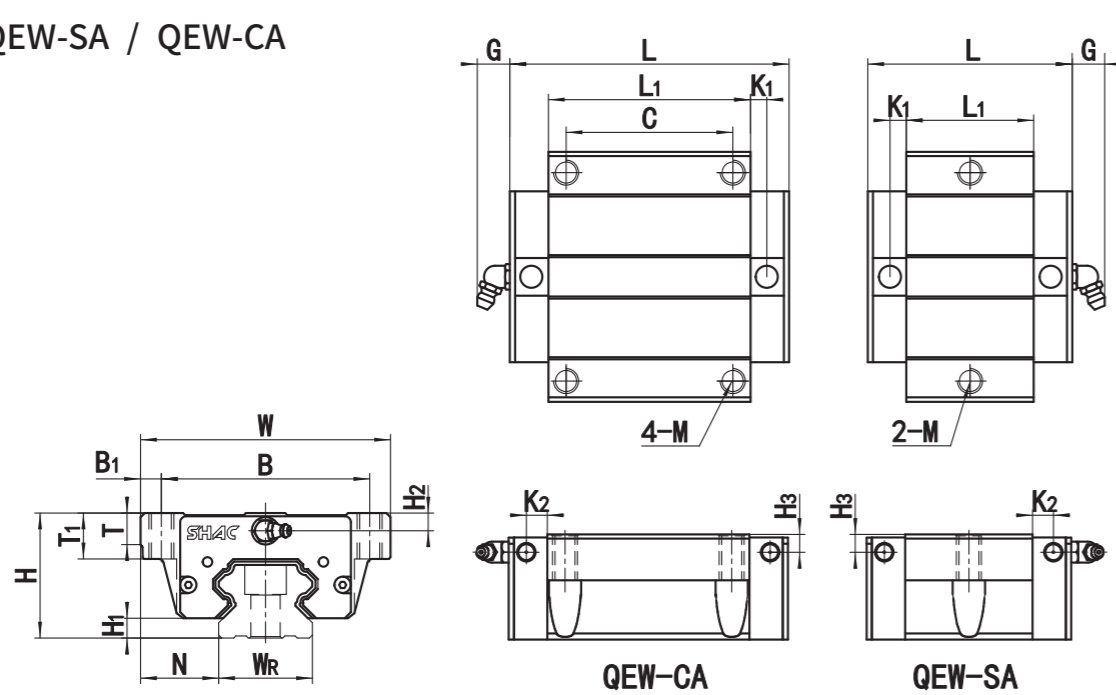

Model No.	Dimensions of Assembly (mm)			Dimensions of Block (mm)													
	H	H ₁	N	W	B	B ₁	C	L ₁	L	K ₁	K ₂	G	M*L	T	T ₁	H ₂	H ₃
★ QEW15SA	24	3.2	18.5	52	41	5.5	-	23.1	45.5	3.5	3.5	5.5	M5	5	7	5.5	5
QEW15CA							26	39.8	62.2								
QEW15SA	24	3.2	18.5	52	41	5.5	-	23.1	45.5	3.5	3.5	5.5	M5	5	7	5.5	5
QEW15CA							26	39.8	62.2								
QEW20SA	28	4.6	19.5	59	49	5	-	29	54	4.75	5	12	M6	7	9	6	6.5
QEW20CA							32	51.5	76.5								
QEW25SA	33	4.5	25	73	60	6.5	-	37.5	60.5	4.75	5	12	M8	7.5	10	6	6
QEW25CA							35	59.5	82.5								
★ QEW30SA	42	7	31	90	72	9	-	41.5	69.5	6	5	12	M10	7	10	8	8
QEW30CA							40	70	98								
QEW30SA	42	7	31	90	72	9	-	41.5	69.5	6	5	12	M10	7	10	8	8
QEW30CA							40	70	98								

Note : 1KN=100kgf
Models marked with ★ feature small mounting holes. Please confirm with sales before placing your order.

Model No.	Dimensions of Rail(mm)								Mounting Bolt for Rail (mm)	Basic Dynamic load Rating C (KN)	Basic Static load Rating C0 (KN)	Static Rated Monent			Weight	
	W _R	H _R	D	h	d	P	E	M _R KN—m				M _P KN—m	M _V KN—m	Block kg	Rail kg/m	
★ GE15	15	12.5	6	4.5	3.5	60	20	M3×16	8.09	8.26	0.06	0.02	0.02	0.14	1.26	
GE15U									11.96	14.46	0.11	0.08	0.08	0.25		
GE15U	15	12.5	7.5	5.3	4.5	60	20	M4×16	8.09	8.26	0.06	0.02	0.02	0.14	1.26	
GE15U									11.96	14.46	0.11	0.08	0.08	0.25		
GE20	20	15.5	9.5	8.5	6	60	20	M5×16	11.46	12.14	0.11	0.04	0.04	0.21	2.09	
GE20									17.46	21.59	0.19	0.13	0.13	0.35		
GE25	23	18	11	9	7	60	20	M6×20	18.81	18.98	0.2	0.09	0.09	0.37	2.69	
GE25									25.65	29.52	0.35	0.27	0.27	0.65		
★ GE30	28	23	11	9	7	80	20	M6×25	24.88	25.96	0.36	0.15	0.15	0.64	4.26	
GE30									36.54	45.12	0.35	0.45	0.45	1.09		
GE30U	28	23	14	12	9	80	20	M8×25	24.88	25.96	0.36	0.15	0.15	0.64	4.26	
GE30U									36.54	45.12	0.35	0.45	0.45	1.09		

Note : 1kgf = 9.81N

QE Series - Silent Low Assembly Ball Linear Guide (injection structure type)

(3) QEW-CB / QEW-SB

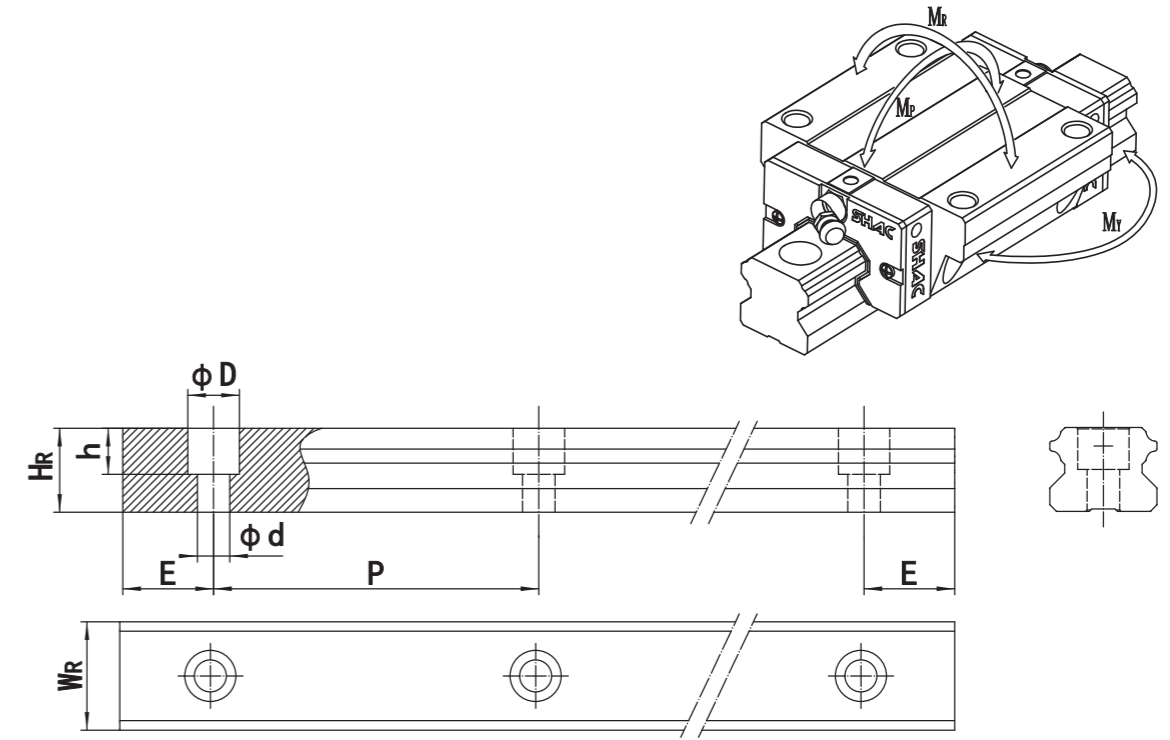
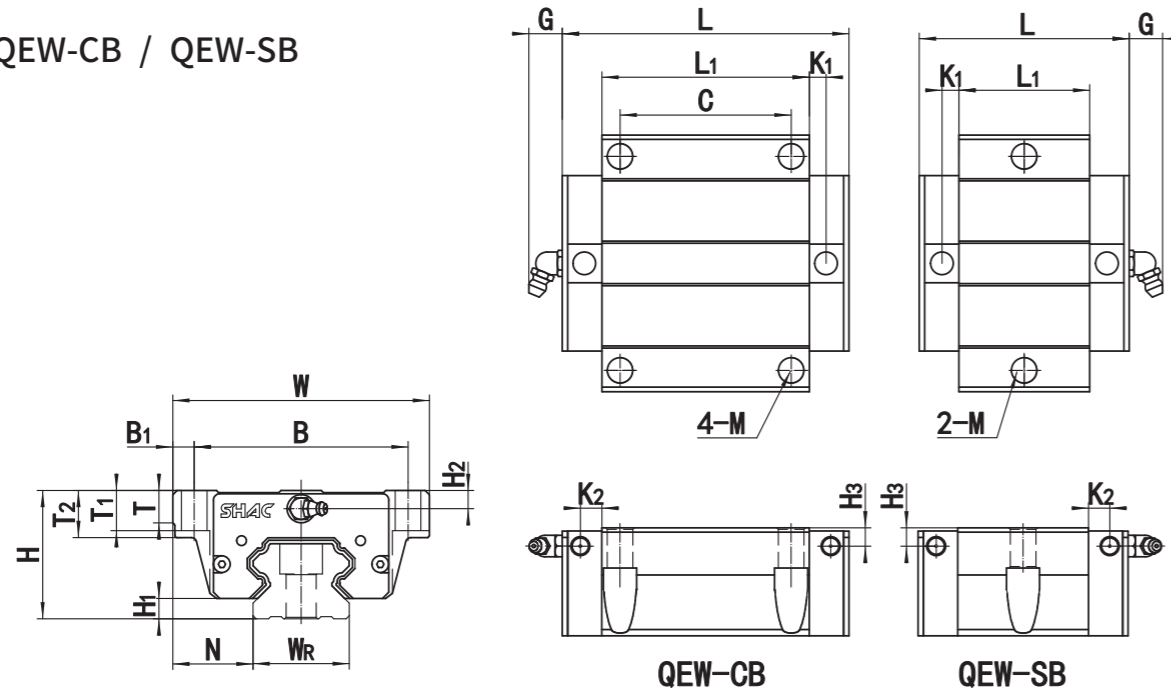

Model No.	Dimensions of Assembly (mm)			Dimensions of Block (mm)													
	H	H ₁	N	W	B	B ₁	C	L ₁	L	K ₁	K ₂	G	M*L	T	T ₁	H ₂	H ₃
★ QEW15SB	24	3.2	18.5	52	41	5.5	-	23.1	45.5	3.5	3.5	5.5	φ4.5	5	7	5.5	5
QEW15CB							26	39.8	62.2								
★ QEW20SB	28	4.6	19.5	59	49	5	-	29	54	4.75	5	12	φ5.5	7	9	6	6.5
QEW20CB							32	51.5	76.5								
★ QEW25SB	33	4.5	25	73	60	6.5	-	37.5	60.5	4.75	5	12	φ7	7.5	10	6	6
QEW25CB							35	59.5	82.5								
★ QEW30SB	42	7	31	90	72	9	-	41.5	69.5	6	5	12	φ9	7	10	8	8
QEW30CB							40	70	98								
★ QEW30SB	42	7	31	90	72	9	-	41.5	69.5	6	5	12	φ9	7	10	8	8
QEW30CB							40	70	98								

Note : 1KN=100kgf

Models marked with ★ feature small mounting holes. Please confirm with sales before placing your order.

Model No.	Dimensions of Rail(mm)							Mounting Boit for Rail (mm)	Basic Dynamic load Rating C (KN)	Basic Static load Rating C0 (KN)	Static Rated Monent			Weight	
	W _R	H _R	D	h	d	P	E				M _R KN-m	M _P KN-m	M _V KN-m	Block kg	Rail kg/m
★ GE15	15	12.5	6	4.5	3.5	60	20	M3×16	8.09	8.26	0.06	0.02	0.02	0.14	1.26
GE15U									11.96	14.46	0.11	0.08	0.08	0.25	
★ GE20	20	15.5	9.5	8.5	6	60	20	M5×16	11.46	12.14	0.11	0.04	0.04	0.21	2.09
GE20U									17.46	21.59	0.19	0.13	0.13	0.35	
★ GE25	23	18	11	9	7	60	20	M6×20	18.81	18.98	0.2	0.09	0.09	0.37	2.69
GE25U									25.65	29.52	0.35	0.27	0.27	0.65	
★ GE30	28	23	11	9	7	80	20	M6×25	24.88	25.96	0.36	0.15	0.15	0.64	4.26
GE30U									36.54	45.12	0.35	0.45	0.45	1.09	
★ GE30U	28	23	14	12	9	80	20	M8×25	24.88	25.96	0.36	0.15	0.15	0.64	4.26
GE30U									36.54	45.12	0.35	0.45	0.45	1.09	

Note : 1kgf = 9.81N

QE Series - Silent Low Assembly Ball Linear Guide (injection structure type)

(4) QEW-CC / QEW-SC

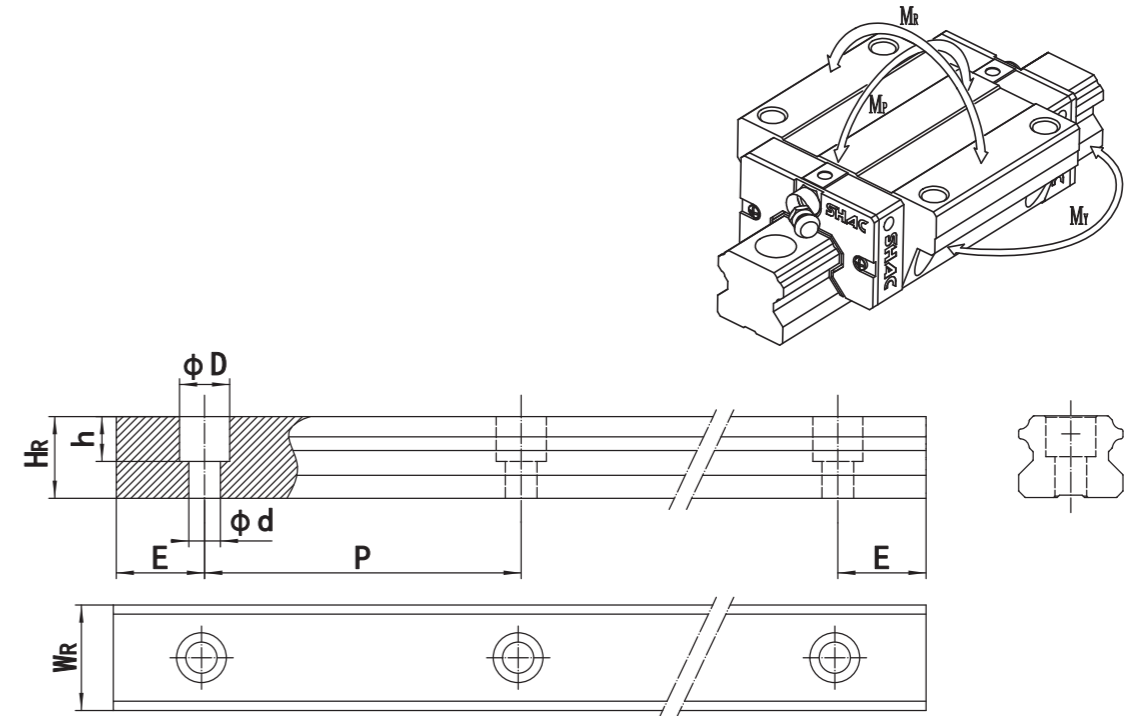
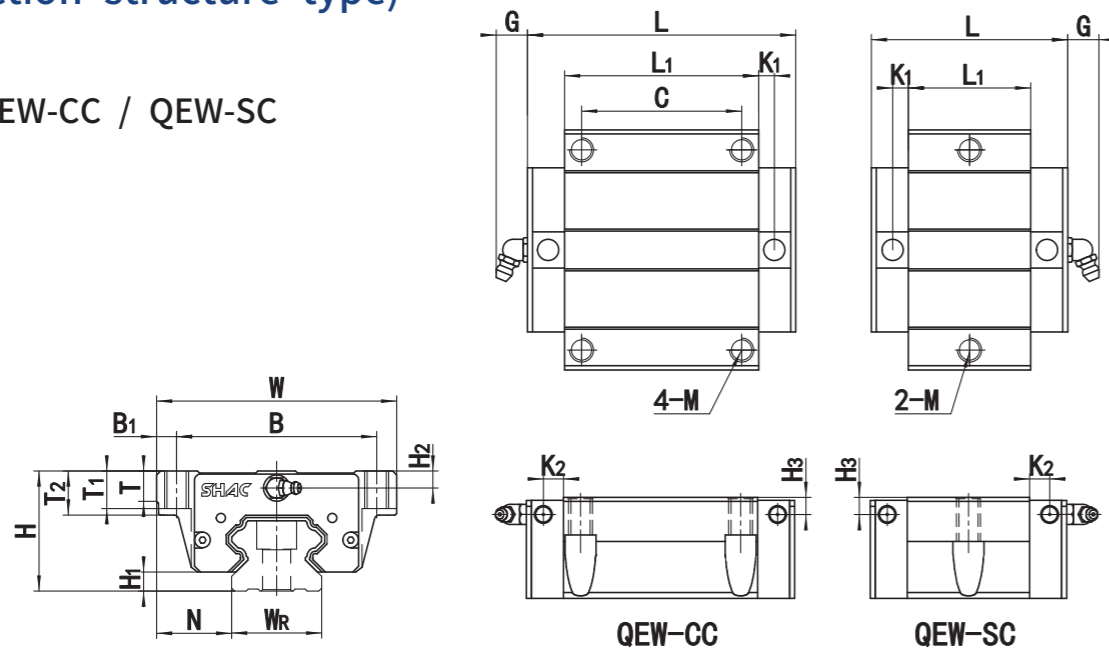

Model No.	Dimensions of Assembly (mm)			Dimensions of Block (mm)														
	H	H ₁	N	W	B	B ₁	C	L ₁	L	K ₁	K ₂	G	M*L	T	T ₁	T ₂	H ₂	H ₃
★ QEW15SC	24	3.2	18.5	52	41	5.5	-	23.1	45.5	3.5	3.5	5.5	M5	5	7	7.8	5.5	5
QEW15CC							26	39.8	62.2									
QEW15SC	24	3.2	18.5	52	41	5.5	-	23.1	45.5	3.5	3.5	5.5	M5	5	7	7.8	5.5	5
QEW15CC							26	39.8	62.2									
QEW20SC	28	4.6	19.5	59	49	5	-	29	54	4.75	5	12	M6	7	7	9	6	6.5
QEW20CC							32	51.5	76.5									
QEW25SC	33	4.5	25	73	60	6.5	-	37.5	60.5	4.75	5	12	M8	7.5	10	10	6	6
QEW25CC							35	59.5	82.5									
★ QEW30SC	42	7	31	90	72	9	-	41.5	69.5	6	5	12	M10	7	10	10	8	8
QEW30CC							40	70	98									
QEW30SC	42	7	31	90	72	9	-	41.5	69.5	6	5	12	M10	7	10	10	8	8
QEW30CC							40	70	98									

Note : 1KN=100kgf
Models marked with ★ feature small mounting holes. Please confirm with sales before placing your order.

Model No.	Dimensions of Rail(mm)							Mounting Boit for Rail (mm)	Basic Dynamic load Rating C(KN)	Basic Static load Rating C0(KN)	Static Rated Monent			Weight	
	WR	HR	D	h	d	P	E				MR KN-m	MP KN-m	MY KN-m	Block kg	Rail kg/m
★ GE15	15	12.5	6	4.5	3.5	60	20	M3×16	8.09	8.26	0.06	0.02	0.02	0.14	1.26
GE15U									11.96	14.46	0.11	0.08	0.08	0.25	
GE15U	15	12.5	7.5	5.3	4.5	60	20	M4×16	8.09	8.26	0.06	0.02	0.02	0.14	1.26
GE15U									11.96	14.46	0.11	0.08	0.08	0.25	
GE20	20	15.5	9.5	8.5	6	60	20	M5×16	11.46	12.14	0.11	0.04	0.04	0.21	2.09
GE20									17.46	21.59	0.19	0.13	0.13	0.35	
GE25	23	18	11	9	7	60	20	M6×20	18.81	18.98	0.2	0.09	0.09	0.37	2.69
GE25									25.65	29.52	0.35	0.27	0.27	0.65	
★ GE30	28	23	11	9	7	80	20	M6×25	24.88	25.96	0.36	0.15	0.15	0.64	4.26
GE30									36.54	45.12	0.35	0.45	0.45	1.09	
GE30U	28	23	14	12	9	80	20	M8×25	24.88	25.96	0.36	0.15	0.15	0.64	4.26
GE30U									36.54	45.12	0.35	0.45	0.45	1.09	

Note : 1kgf = 9.81N

2-6 GR Series - Roller Linear Guide

Product characteristics

SHAC's GR series roller linear guide rail uses cylindrical roller to replace the common steel ball roller, and the rolling body is in line contact with the guide rail and slider. Compared with the point contact type of common steel ball linear guide rail, it can provide higher rigidity and load capacity under the same specification

DB45 degree combination type is adopted for four rows of rollers, with optimized structure and high rigid section design, and four-direction equal load capacity

At the same time, each row of rollers is equipped with silent chain belt to prevent mutual friction between rollers, effectively reduce the running noise of guide rail pair, make the rollers more stable when entering and leaving the load area and non-load area, and greatly improve the stability and smoothness of operation,

Extra heavy load

The common steel ball rolling elements are replaced by cylindrical rollers, and the rolling elements are in linear contact with the guide rail and the sliding block. Compared with the point contact type of common steel ball linear guide rail, it can provide higher load capacity under the same specification

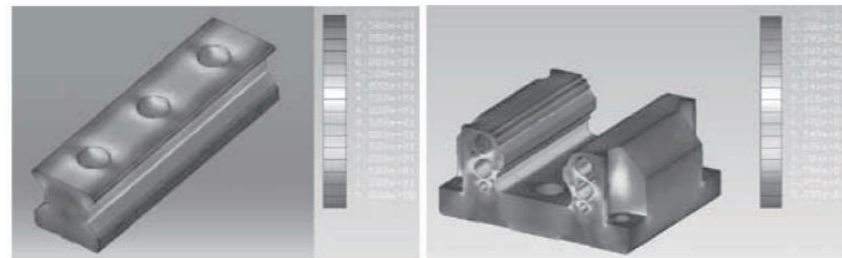

Figure 2-5-1

Super high rigidity

The optimized slider and guide rail structure and high rigid section design, combined with the inherent advantages of roller on ball mechanics, make GR series roller linear guide rail have the characteristics of ultra-high rigidity

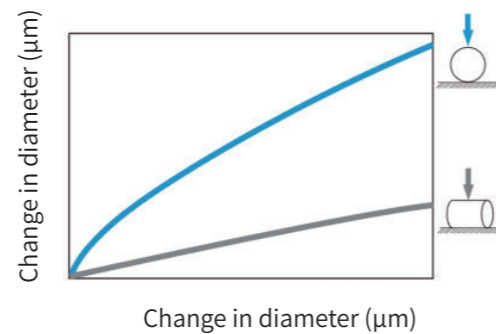

Figure 2-5-2

Four directional equal load capacity

DB45 degree combination type is adopted for four rows of rollers, with optimized structure and high rigid section design, and four-direction equal load capacity

It can be used regardless of various mounting methods of XYZ equal-axis

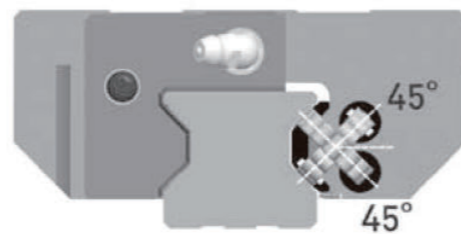

Figure 2-5-3

GR Series - Roller Linear Guide

Service Life

Without considering the impact of environmental factors, the service life is calculated as follows:

$$L = \left(\frac{C}{P} \right)^{\frac{10}{3}} \cdot 100\text{km} = \left(\frac{C}{P} \right)^{\frac{10}{3}} \cdot 62\text{mile}$$

If the environmental factors for the use of linear guide rail are taken into consideration, its service life will vary with the motion state, surface hardness of bead pass and system temperature

$$L = \left(\frac{f_a \cdot f_b \cdot C}{f_c \cdot P} \right)^{\frac{10}{3}} \cdot 100\text{km} = \left(\frac{f_a \cdot f_b \cdot C}{f_c \cdot P} \right)^{\frac{10}{3}} \cdot 62\text{mile}$$

L: Life
P: Working load
C: Basic rated dynamic load
f_a: Hardness coefficient
f_b: Temperature coefficient
f_c: Load coefficient

The temperature coefficient, hardness coefficient and load coefficient are the same as those of the linear roller guideway. Compared with the ball linear guide rail, the GR-series have an ultra-strong load capacity, which can greatly improve the service life

Durability test

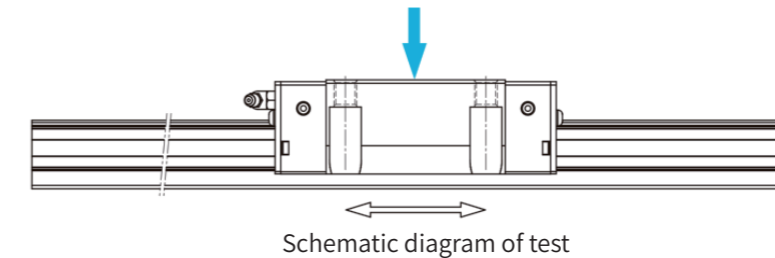

Figure 2-5-4

Table 2-5-1 Test Conditions
Test piece 1: GRH35CA
Preloading grade: ZA
Moving speed: 60m/min
Acceleration: 1G
Stroke: 0.55m
Lubricating grease: supplement once every 100km
Applied load: 15KN
Running distance: 1200km



Figure 2-5-5

Test results: According to the service life formula, the service life of GRH35CA is calculated as 1000km. No structural damage was found on the surface of ball track and roller after the test piece was operated for 1200km

Test piece 2: GRW35CC
 Preloading grade: ZA
 Moving speed: 120m/min
 Acceleration: 1G
 Travel: 2m
 Lubricating oil frequency: 0.3cm
 cubic meter/h cubic meter/hr
 Applied load: no load
 Running distance: 15000km



Figure 2-5-6

Test results: GRW35CC after the test piece runs for 15000 km, no structural damage is found on the surface of Steel Roller and roller

Note: the above data are sample data

Product structure

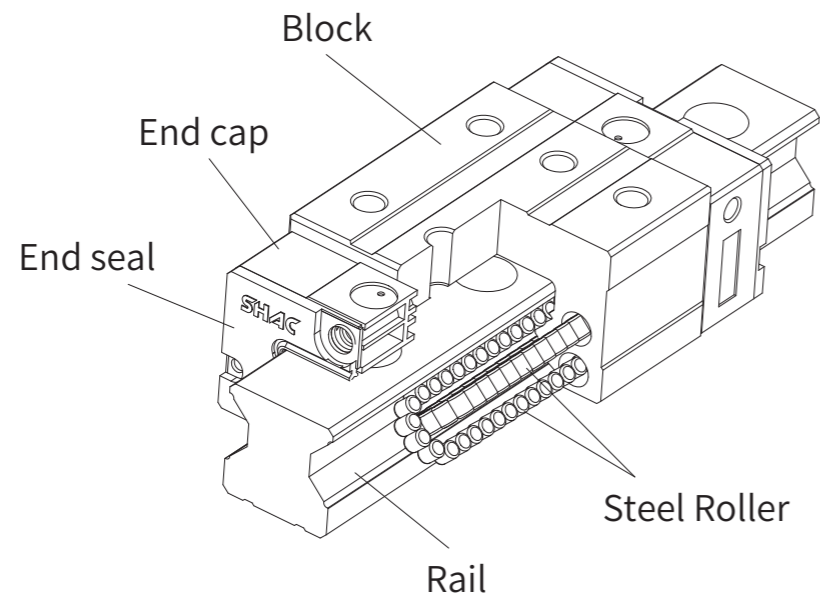

Figure 2-5-7

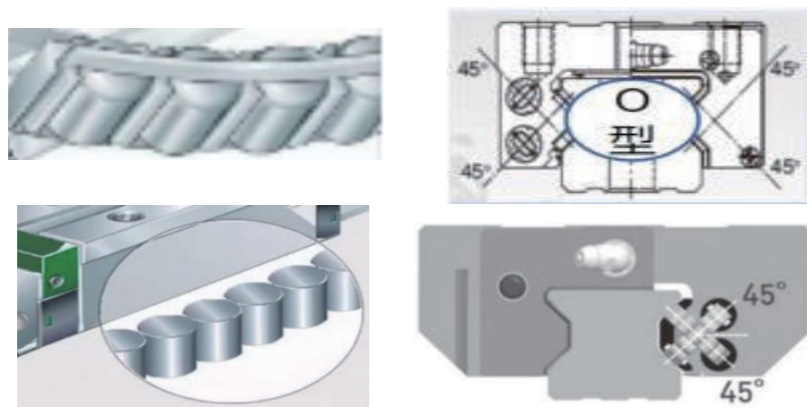

Figure 2-5-8

Recommended Applicable Equipment

NC heavy equipment: Instrument tool machine, grinder, Gantry type machine tool, injection molding machine, etc.

Table 2-5-1

Item	Product advantages	Corresponding efficiency
1	Super Load	Replacing conventional steel ball rolling elements with cylindrical rollers, changing from point contact bearing to line contact bearing, can provide higher load capacity under the same specifications
2	Ultra high rigidity	The optimized slider and guide rail structure, as well as the high rigidity cross-sectional design, combined with the inherent advantages of rollers in ball mechanics, make the GR series guide rail have the characteristic of ultra-high rigidity
3	DB45°combination	The four column roller adopts a 45 degree combination design, and the O-shaped load-bearing structure can provide equal load capacity in all directions
4	Pre compression adaptation	Four level standard pre pressure is available for selection, which can further improve walking accuracy and rigidity
5	Dust proof accessories	Standard dustproof configuration and optional DD, KK, ZZ dustproof kits can better adapt to the environment
6	Lubrication options	Multiple types of nozzles are paired with eight nozzle positions at both ends, and the slider specifies the oil capacity and recommended fuel supply rate, making use more reassuring

2-6-1 Product model of non-interchangeable linear guide rail

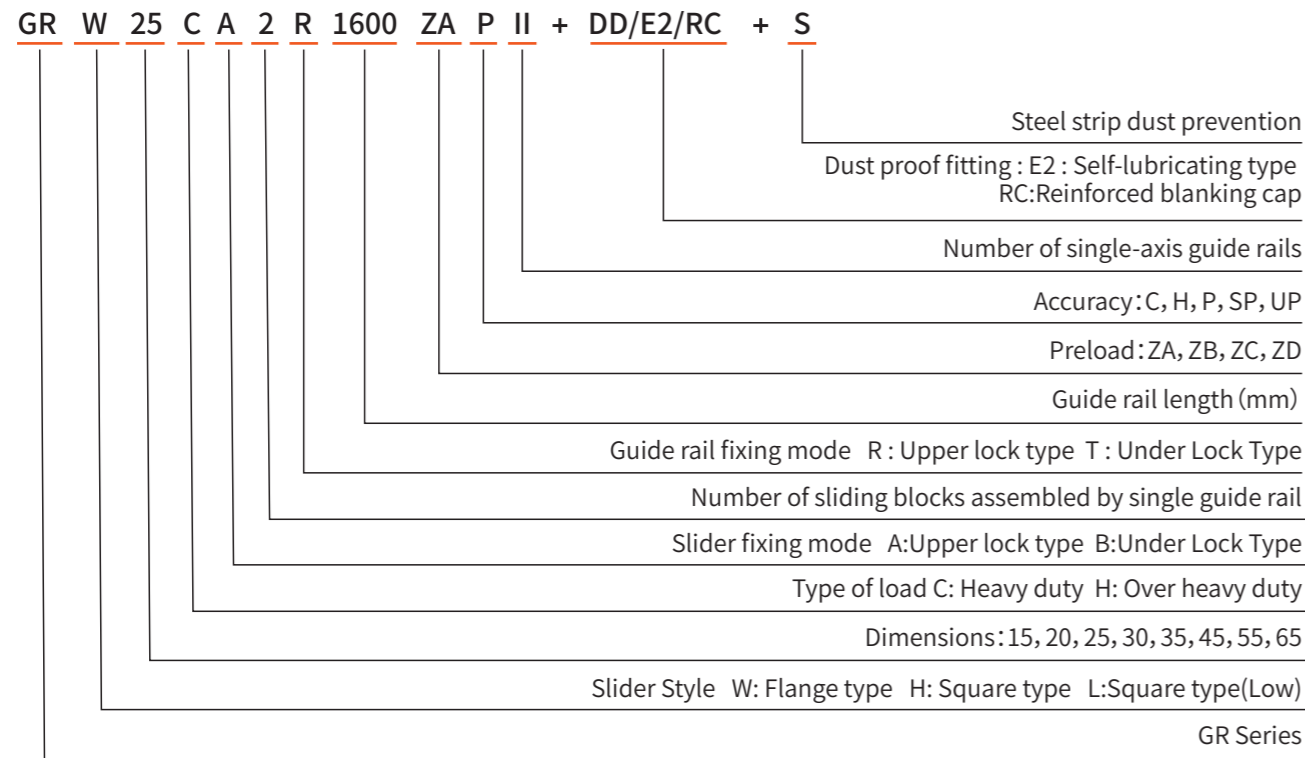

Note:

1. The number of single-axis guide rails shall not be written if only — support guide rails are used. Two guide rails are marked as II, three guide rails are marked as III, and so on.
2. The dust proof accessories with several weights are standard dust proof accessories with dust strip.

ZZ: dust strip, dust strip and metal scraper.

KK is double dust proof, dust strip and metal scraper.

DD DUAL DUAL DUST FINS WITH DUST STRIPS.

The sliding block type L is the low assembled sliding block of square type H, and the combined height is consistent with the flange type of the same size.

2-6-2 Product model of interchangeable linear guide rail

Product model of interchangeable sliding block

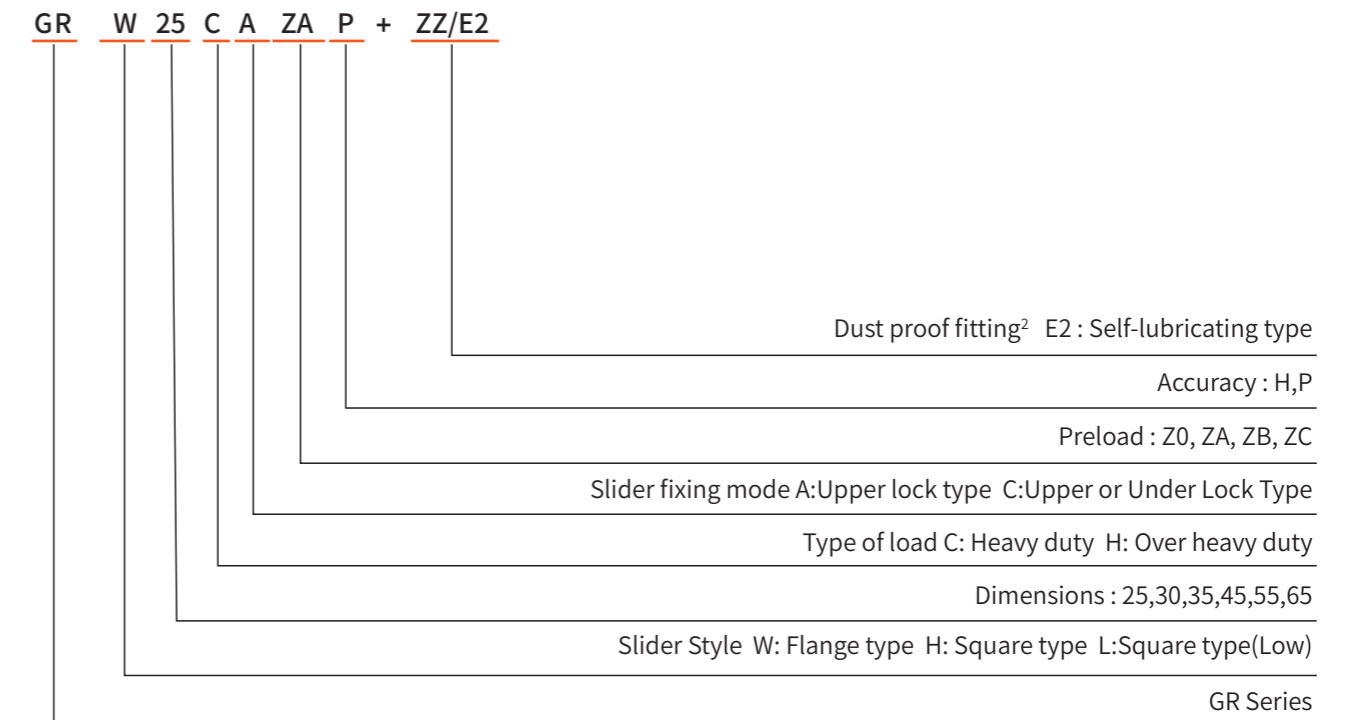

Product model of interchangeable guide rail

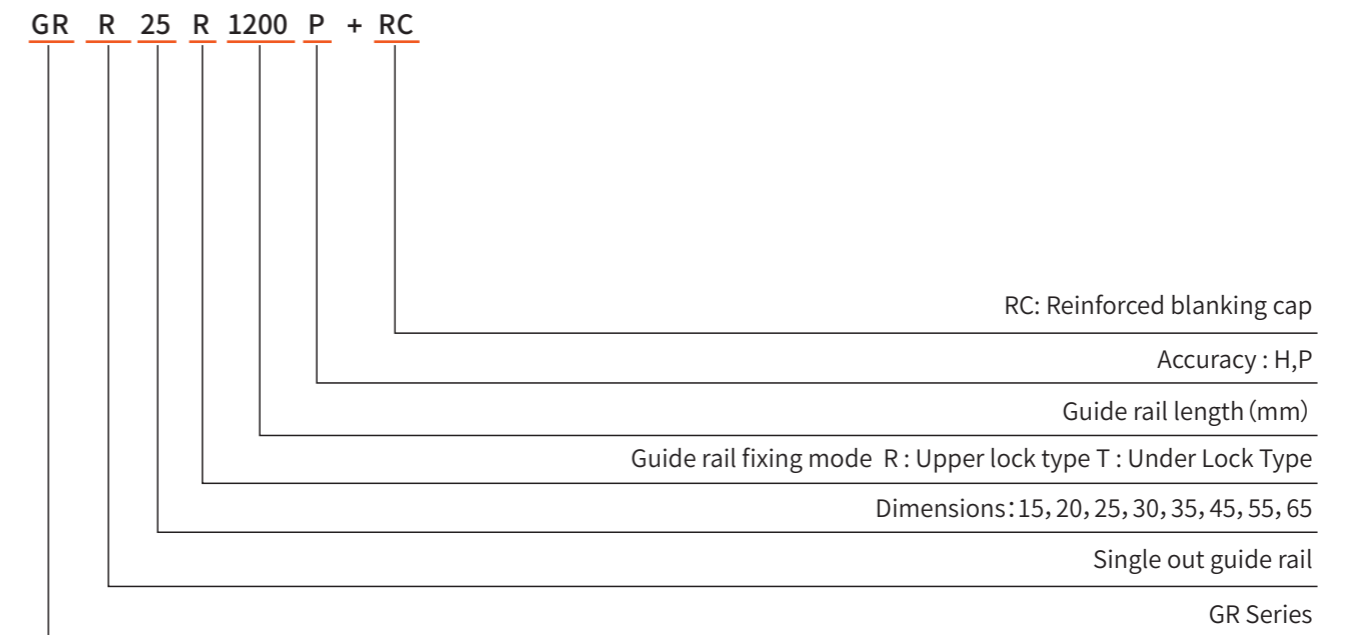

2-6-3 GR Series - Roller Linear Guide

(1) Slide block type

SHAC provides flange type and square type linear guide rails. The overall assembly height of flange row is lower and wider. The threaded holes and through holes machined at the flange part can meet the installation of bottom lock type. The square linear guide rail is divided into H type and L type. L type is the low assembly type linear guide rail of H type, and the assembly height is the same as that of flange row linear guide rail

Table 2-5-2 Block Type

Unit : mm

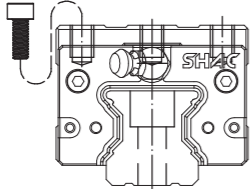
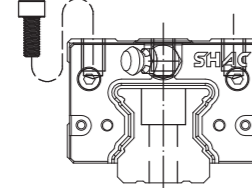
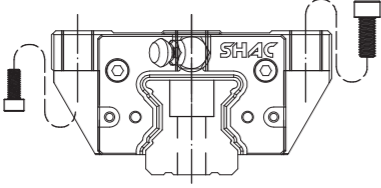
Style	Specification	SHAPE	Height dimension (mm)	Guide rail length (mm)	Equipment suitable for application
Square	GRH-CA GRH-HA		40	100	<ul style="list-style-type: none"> Large gantry machine tool Heavy cutting machine CNC machining machine CNC grinding machine
			90	6000	
Square	GRL-CA GRL-HA		36	100	<ul style="list-style-type: none"> injection molding machine Heavy duty automation equipment Work machinery with high rigidity and heavy load requirements
			70	6000	
Flange	GRW-CC GRW-HC		36	100	<ul style="list-style-type: none"> Precision heavy-duty handling equipment
			90	6000	

(2) Guideways Type

In addition to the general upper locking screw hole guides, SHAC also offers locking screw hole guides from bottom locking for easy installation by the customer.

Table 2-5-2 Guideways Type

Mounting from Top

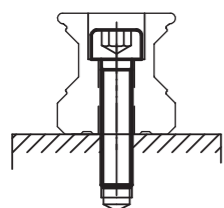

Mounting from Bottom

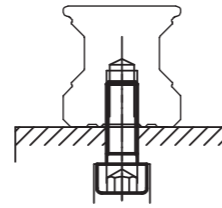

Figure 2-5-9

Grade of Accuracy

The accuracy of GR series linear guide rail can be divided into four levels: high level(H), precision level(P), ultra-precision level(SP) and ultra-high precision level(UP). Customers can select products of corresponding level according to the equipment accuracy requirements

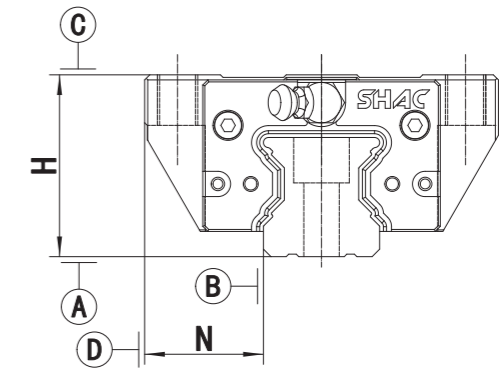

Figure 2-5-10

2-6-4 Precision of non-interchangeable linear guide rail

Table 2-5-3 Assembly accuracy table

Unit : mm

Model No.	GR-25, 30, 35			
Grade of accuracy	Ultra-Precision Level (UP)	Super-Precision Level (SP)	Precision Level (P)	High Level (H)
Allowable dimension error of height H	0 -0.01	0 -0.02	0 -0.04	±0.04
Allowable error of width N	0 -0.01	0 -0.02	0 -0.04	±0.04
Mutual error of paired width H	0.003	0.005	0.007	0.015
Allowable error of paired width N	0.003	0.005	0.007	0.015
Traveling parallelism of slide block C to surface A of guide rail	Travel parallelism (see Table 2-5-9)			
Traveling parallelism of slide block D to surface B of guide rail				

Table 2-5-3 Assembly accuracy table

Unit : mm

Model No.	GR-45, 55			
Grade of accuracy	Ultra-Precision Level (UP)	Super-Precision Level (SP)	Precision Level (P)	High Level (H)
Allowable dimension error of height H	0 -0.02	0 -0.03	0 -0.05	±0.05
Allowable error of width N	0 -0.02	0 -0.03	0 -0.05	±0.05
Mutual error of paired width H	0.003	0.005	0.007	0.015
Allowable error of paired width N	0.005	0.007	0.01	0.02
Traveling parallelism of slide block C to surface A of guide rail	Travel parallelism (see Table 2-5-9)			
Traveling parallelism of slide block D to surface B of guide rail				

Table 2-5-5 Assembly accuracy table

Unit : mm

Model No.	GR-65			
Grade of accuracy	Ultra-Precision Level (UP)	Super-Precision Level (SP)	Precision Level (P)	High Level (H)
Allowable dimension error of height H	0 -0.03	0 -0.05	0 -0.07	±0.07
Allowable error of width N	0 -0.03	0 -0.05	0 -0.07	±0.07
Mutual error of paired width H	0.005	0.007	0.01	0.02
Allowable error of paired width N	0.007	0.01	0.015	0.025
Traveling parallelism of slide block C to surface A of guide rail	Travel parallelism (see Table 2-5-9)			
Traveling parallelism of slide block D to surface B of guide rail				

2-6-5 Precision of interchangeable linear guide rail

Table 2-5-6 Single Output Accuracy Table

Unit : mm

Model No.	GR—25, 30, 35	
Grade of accuracy	Precision Level (P)	High Level (H)
Allowable dimension error of height H	±0.02	±0.04
Allowable error of width N	±0.02	±0.04
Mutual error of paired width H	0.007	0.015
Allowable error of paired width N	0.007	0.015
Traveling parallelism of slide block C to surface A of guide rail	Travel parallelism (see Table 2-5-9)	
Traveling parallelism of slide block D to surface B of guide rail		

Table 2-5-7 Single Output Accuracy Table

Unit : mm

Model No.	GR—45, 55	
Grade of accuracy	Precision Level (P)	High Level (H)
Allowable dimension error of height H	±0.025	±0.05
Allowable error of width N	±0.025	±0.05
Mutual error of paired width H	0.007	0.015
Allowable error of paired width N	0.01	0.02
Traveling parallelism of slide block C to surface A of guide rail	Travel parallelism (see Table 2-5-9)	
Traveling parallelism of slide block D to surface B of guide rail		

Table 2-5-8 Single Output Accuracy Table

Unit : mm

Model No.	GR—45, 55	
Grade of accuracy	Precision Level (P)	High Level (H)
Allowable dimension error of height H	±0.035	±0.07
Allowable error of width N	±0.035	±0.07
Mutual error of paired width H	0.01	0.02
Allowable error of paired width N	0.015	0.025
Traveling parallelism of slide block C to surface A of guide rail	Travel parallelism (see Table 2-5-9)	
Traveling parallelism of slide block D to surface B of guide rail		

2-6-6 Travel parallelism accuracy

Table 2-5-9

Guide rail length (mm)	Grade of accuracy (μm)			
	UP	SP	P	H
~100	2	2	3	7
100~200	2	2	4	9
200~300	2	3	5	10
300~500	2	3	6	12
500~700	2	4	7	13
700~900	3	5	8	15
900~1100	3	6	9	16
1100~1500	4	7	11	18
1500~1900	4	8	13	20
1900~2500	5	10	15	22
2500~3100	6	11	18	25
3100~3600	7	14	20	27
3600~4000	7	15	21	28

Preload

The so-called preloading refers to the process of increasing the diameter of the roller to create a negative gap between the roller and the channel, and applying a load to the interior in advance. Through preloading assembly, not only can the gap be eliminated, but the rigidity and walking accuracy of the slider can also be improved.

2-6-7 Grade of Preload

The GR series linear guide has three preloading standards to choose from. Suitable preloading can improve accuracy and rigidity, while excessive preloading can have a certain impact on service life. Therefore, the appropriate preloading should be selected according to the model and purpose. For example, it is recommended to choose a lighter preloading for small models

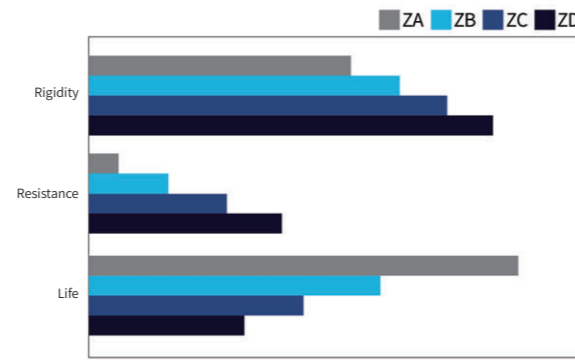

Figure 2-5-11

Table 2-5-10 Grade of Preload

Grade of Preload	Code	Preload	Scooes of application
No preload	ZA	0~0.04C	Fixed load direction, small impact and low precision requirements
Light preload	ZB	0.04C~0.08C	Light duty and high accuracy required
Medium preload	ZC	0.08C~0.12C	High rigidity, vibration and impact environment
Heavy preload	ZD	0.12~0.16C	It requires higher rigidity and has a service environment with large vibration and impact

Note: C in the pre pressure is the rated dynamic load

2-6-8 Way of lubrication

- ◎ See pages 26 and 27 for choke style
- ◎ Location of choke: we can install choke at the front end or rear end of the slider according to customer requirements, and the side of the end cover is also reserved with the location of choke mounting hole for the convenience of oil injection from the side. According to different injection methods, the choke can be divided into common choke and special oil pipe connector
- ◎ See pages 29, 30 for nozzle details

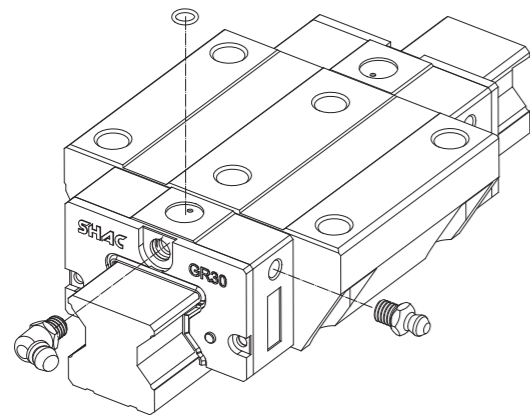

Figure 2-5-12

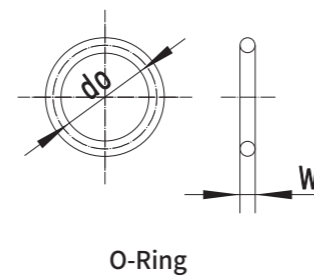

Figure 2-5-13

Table 2-5-11 O-Ring Size and Maximum Allowable Depth

Specification	O-Ring Size		Maximum Allowable Depth Tmax (mm)
	do (mm)	W (mm)	
GR20	7.5±0.15	1.5±0.15	4
GR25	7.5±0.15	1.5±0.15	5.8
GR30	7.5±0.15	1.5±0.15	6.2
GR35	7.5±0.15	1.5±0.15	8.65
GR45	7.5±0.15	1.5±0.15	9.5
GR55	7.5±0.15	1.5±0.15	11.6
GR65	7.5±0.15	1.5±0.15	14.5

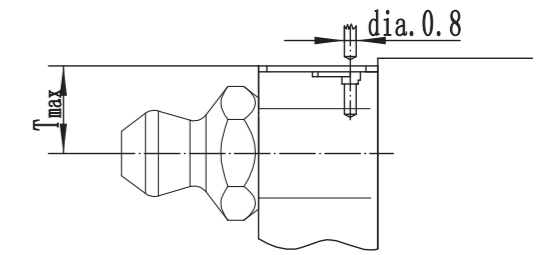

Figure 2-5-14

2-6-9 Lubricating oil capacity of single sliding block

Table 2-5-12

Specification	CA (cm³)	HA (cm³)	Specification	CA (cm³)	HA (cm³)
GR20	5	6	GR45	19	23
GR25	7	8	GR50	28	35
GR30	9	10	GR65	52	63
GR35	12	14	GR85	83	97

Lubrication mode and frequency

Confirm the grease every 100km of operation or every 3 to 6 months

Oil feed rate :

Table 2-5-13

Specification	Oil feed rate (cm³ /hr)
GR20	0.1
GR25	0.167
GR30	0.2
GR35	0.23
GR45	0.3
GR55	0.367
GR65	0.433
GR85	0.54

2-6-10

Dust proof fitting and code

Generally, the standard dustproof is used in the operating environment without special requirements. If the following dustproof accessories are required, please mark the code behind the product model.

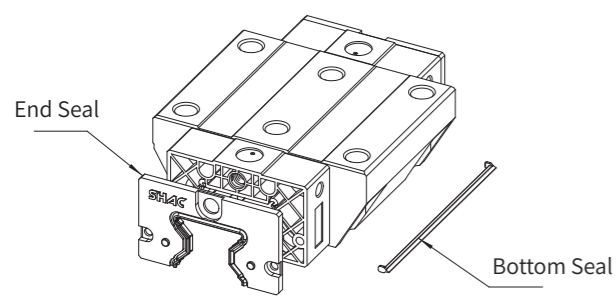

No marked as dustproof standard accessories
(End seal+Bottom Seal)

Figure 2-5-15

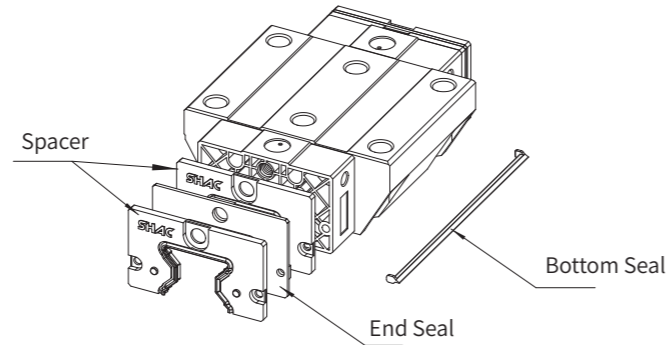

DD(Double End Seal+Bottom Seal)

Figure 2-5-16

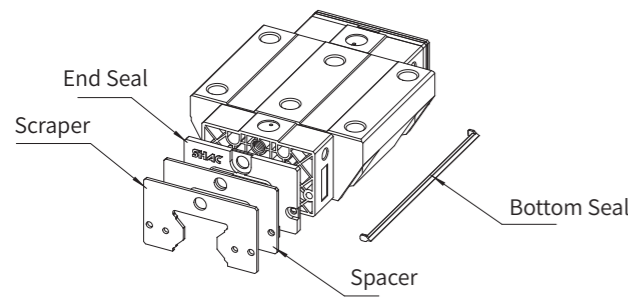

ZZ(End seal+Bottom Seal+Scraper)

Figure 2-5-17

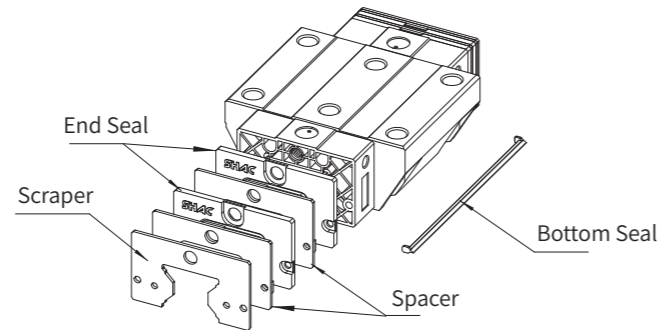

KK(Double End seal+Bottom Seal+Scraper)

Figure 2-5-18

Dust-proof fitting description

When the slider moves back and forth, scrap iron and other debris will enter the slider to damage the surface of the channel and reduce the service life of the linear guide rail. Dust, wood chips and other foreign matters will accumulate in the channel and cause blockage. Proper dust prevention measures must be taken to ensure its service life.

End seal and bottom seal

The end seal and the bottom seal can effectively prevent debris or dust from entering the inside of the slider.

Double end seal

Double dustproof effect, even in worse processing environment, it can also have excellent dustproof effect.

Table 2-5-14 Thickness of End seal

Specification	Thickness (mm)	Specification	Thickness (mm)
GR20	1.8	GR45	2.3
GR25	2.4	GR55	2.4
GR30	2.6	GR65	2.6
GR35	2.4	GR85	3.0

Metal scraper

Thanks to the high temperature resistance and high hardness of metal, it can effectively isolate high-temperature scrap iron and large foreign matters.

Space

Superimposed two dust sheets will affect the cooperation between guide rail and dust sheet, increase friction force, separate two dust sheets with grid piece, ensure real prepressing, reduce friction force and effectively prevent dust.

Table 2-5-15 Thickness of Metal scraper

Specification	Thickness (mm)	Specification	Thickness (mm)
GR20	1.0	GR45	2
GR25	1.5	GR55	2.2
GR30	1.6	GR65	1.5
GR35	1.5	GR85	2

Table 2-5-16 Thickness of Space

Specification	Thickness (mm)	Specification	Thickness (mm)
GR20	1.3	GR45	2
GR25	2	GR55	2.2
GR30	1.5	GR65	1.5
GR35	1.5	GR85	2

Guide rail blanking cover

Dust and foreign matters will enter the inside of the slider through the mounting hole, affecting the accuracy and service life. Use a special blanking cap to block the mounting hole so that the mounting hole plane and the guide rail plane are at the same height, which can effectively prevent foreign matters from entering the slider.

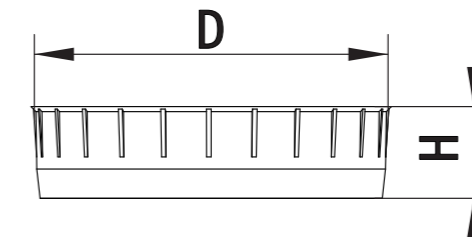

Figure 2-5-19

Table 2-5-17 Guide rail blanking cover

Guide rail specification	Screw Size	Diameter (D) (mm)	Thickness (H) (mm)	Guide rail specification	Screw Size	Diameter (D) (mm)	Thickness (H) (mm)
GR20	M5	9.75	3.2	GR45	M12	20.25	4.6
GR25	M6	11.15	2.5	GR55	M14	23.5	5.5
GR30	M8	14.20	3.3	GR65	M16	26.6	5.5
GR35	M8	14.20	3.3	GR85	M20	35.6	5.5

Friction force

The resistance values in the table below are the maximum resistance of two dust-proof sheets

Table 2-5-18 Resistance value of dust sheet

Specification	Resistance value of dust sheet N (kgf)	Specification	Resistance value of dust sheet N (kgf)
GR20	6 (0.61)	GR45	18 (1.83)
GR25	12 (1.2)	GR55	20 (2)
GR30	14 (1.4)	GR65	22 (2.24)
GR35	16 (1.63)	GR85	26 (2.65)

注:1kgf=9.81N

TOTAL SLIDE LENGTH PER DUST CODE

Table 2-5-19 Total block length per dust code

Specification	Total block length (L) (mm)			
	Standard	ZZ	DD	KK
GR20C	86.7	91.3	92.9	97.5
GR20H	106.7	111.3	112.9	117.5
GR25S	96.3	103.3	105.1	112.1
GR25C	107.7	114.7	116.5	123.5
GR25H	124.2	131.2	133	140
GR30C	114	120.2	122.2	128.4
GR30H	136	142.2	144.2	150.4
GR35C	131	137	138.8	144.8
GR35H	159	165	166.8	172.8
GR45C	157.8	164.8	166.4	173.4
GR45H	193.8	200.8	202.4	209.4
GR55C	182.3	189.7	191.5	198.9
GR55H	233.3	240.7	242.5	249.9
GR65C	226.1	232.1	234.3	240.3
GR65H	292.6	298.6	300.8	306.8

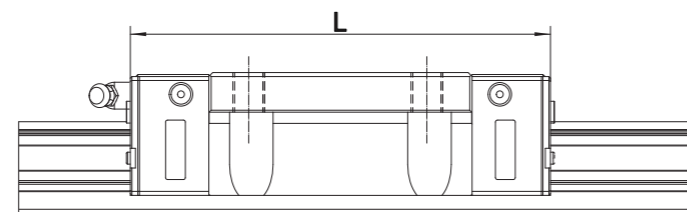

Figure 2-5-20

2-6-11 Allowable error of installation surface

Due to the superior rigidity of the GR series roller linear guide, it is sensitive to the accuracy error of the installation surface. When the accuracy error of the installation surface is too large, it will not only increase frictional resistance and reduce the quality of operation, but also reduce the service life

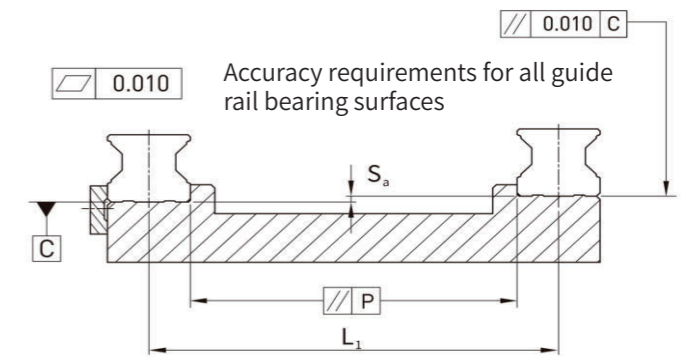

Figure 2-5-21

Allowable error of mounting surface

Table 2-5-20 Allowable parallelism max. error (P)
单位: μm

Specification	Grade of preload		
	ZA	ZB	ZC
GR20	7	6	4
GR25	9	7	5
GR30	11	8	6
GR35	14	10	7
GR45	17	13	9
GR55	21	14	11
GR65	27	18	14
GR85	35	23	18

Parallelism error of bearing surface (Sa)

$$S_a = L_1 \times K$$

S_a: Maximum allowable height error

L₁: Matching rail spacing

K: Height error coefficient

Table 2-5-21 Height error coefficient

Specification	Grade of preload		
	Z0	ZA	ZB
K	2.2×10^{-4}	1.7×10^{-4}	1.2×10^{-4}

2-6-12 Plane precision of slide block installation

The height error S_b of the bearing surface of different support rail slider pairs

$$S_b = b \times 4.2 \times 10^{-5}$$

S_b: Maximum allowable height error

b: Matching rail spacing

The height error S_c of the matching bearing surface of the same guide rail

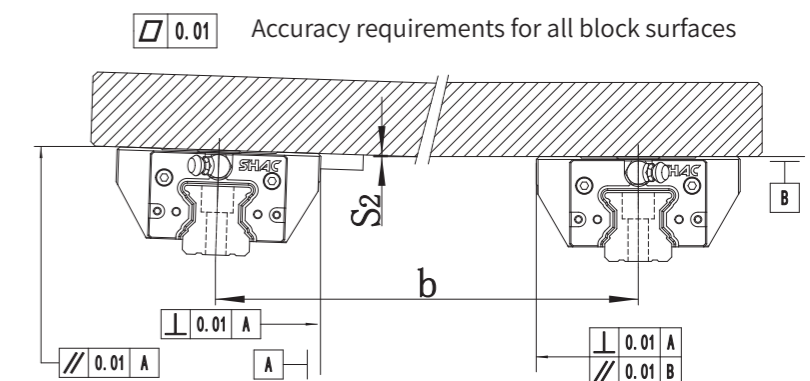

Figure 2-5-22

2-6-13 Precautions for installation

(1) Bearing surface height and chamfer

When installing linear guides, it is important to pay attention to whether the size of the bearing surface is appropriate. For example, excessive chamfers can cause the reverse rail to not fully adhere to the bearing surface, which can lead to poor accuracy of the linear guide. Conversely, excessively high bearing surfaces can conflict with the bottom height of the slider, making installation impossible.

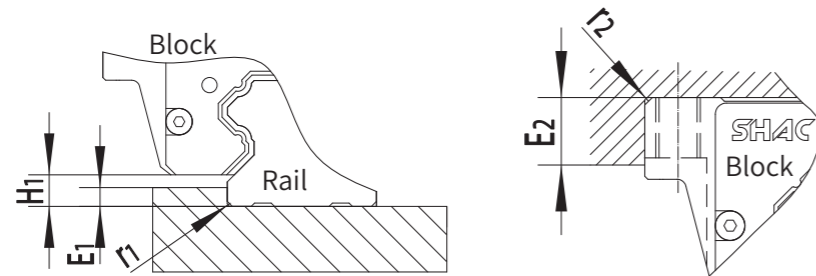

Figure 2-5-23

Table 2-5-22 Bearing surface height and chamfer

Specification	Max. Guide rail end r_1 (mm)	Max. Slide end Radius of fillet r_2 (mm)	Max. Slide end E_1 (mm)	Guide rail end bearing Height of abutting surface E_2 (mm)	Clear height of slide block H_1 (mm)	Chamfer dimensions for linear guide
						A/B
GR25	1.0	1.0	5	5	5.5	1.5
GR30	1.0	1.0	5	5	6	1.5
GR35	1.0	1.0	6	6	6.5	1.5
GR45	1.0	1.0	7	8	8	2
GR55	1.5	1.5	9	10	10	2
GR65	1.5	1.5	10	10	12	2

(2) Specification and torsion of guide rail mounting screw

The locking force of the mounting screws of the linear guide rail directly affects the service life and accuracy of the guide rail. Therefore, it is important to use a torque wrench to lock each screw with an appropriate torque value.

Table 2-5-23 Torque value

Specification	Screw size	Torque value N-cm (kgf-cm)		
		Iron parts	Casting	Aluminium alloy
GR20	M5×0.8P×16L	883 (90)	588 (60)	441 (45)
GR25	M6×1P×20L	1373 (140)	921 (94)	686 (70)
GR30	M8×1.25P×25L	3041 (310)	2010 (205)	1470 (150)
GR35	M8×1.25P×25L	3041 (310)	2010 (205)	1470 (150)
GR45	M12×1.75P×35L	11772 (1200)	7840 (800)	5880 (600)
GR55	M14×25P×45L	15696 (1600)	10500 (1100)	7840 (800)
GR65	M16×2P×50L	19620 (2000)	13100 (1350)	9800 (1000)

2-6-14 Standard length and maximum length of a single guide rail

We will have a certain amount of standard length stock of guide rails. If you want to customize non-standard length guide rails, it is best not to have the end distance E greater than $1/2$ of the hole distance. Excessive end distance can cause instability after the installation of the guide rail, affecting the accuracy of the linear guide rail.

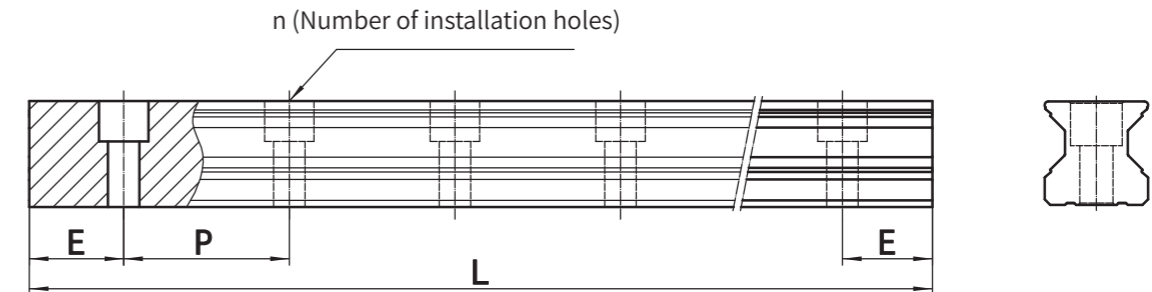

Figure 2-5-24

Table 2-5-24 Length of Rail

Unit: μm

Item	GRR20	GRR25	GRR30	GRR35	GRR45	GRR55	GRR65
Standard length L (n)		220 (7)	280 (7)	280 (7)	570 (11)	780 (13)	1270 (17)
		280 (9)	440 (11)	440 (11)	885 (17)	1020 (7)	1570 (21)
		340 (11)	600 (15)	600 (15)	1200 (23)	1260 (21)	2020 (27)
		460 (15)	760 (19)	760 (19)	1620 (31)	1500 (25)	2620 (35)
		640 (21)	1000 (25)	1000 (25)	2040 (39)	1980 (33)	-
		820 (27)	1640 (41)	1640 (41)	2460 (47)	2580 (43)	-
		1000 (33)	2040 (51)	2040 (51)	2985 (57)	2940 (49)	-
		1240 (41)	2520 (63)	2520 (63)	3090 (59)	3060 (51)	-
		1600 (53)	3000 (75)	3000 (75)	-	-	-
hole pitch (P)		30	40	40	52.5	60	75
Standard end distance (E)		20	20	20	22.5	30	35
Max. length of standard end distance		4000 (133)	4000 (100)	4000 (100)	3982.5 (76)	3960 (66)	3970 (53)
Max. length		6000	6000	6000	6000	6000	6000

Note:

- The general tolerance for the distance between guide rail ends is $\pm 0.5\text{mm}$, while the tolerance for the distance between guide rail ends on the street is more strict, ranging from 0 to 0.3mm.
- The maximum standard end distance refers to the maximum length of the guide rail where both the left and right end distances are standard end distances.
- If the customer requires end distances of different sizes, please contact SGAC sales or engineering personnel.

GR Series - Roller Linear Guide

(1) GRH-SA / GRH-CA / GRH-HA

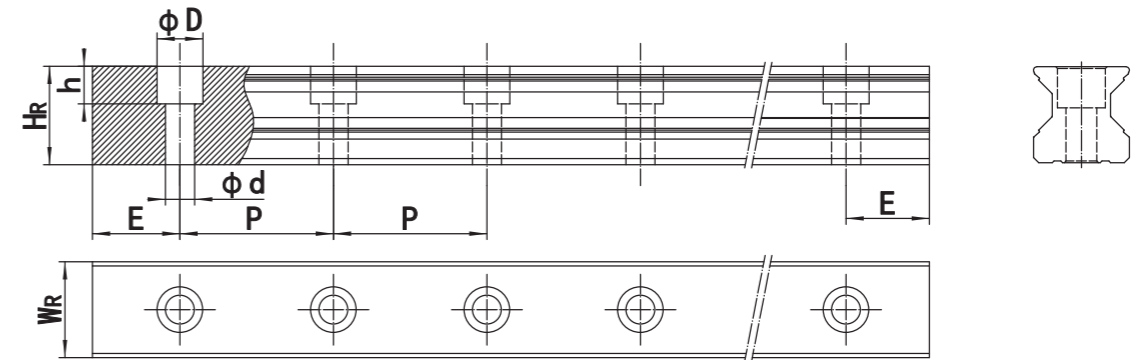
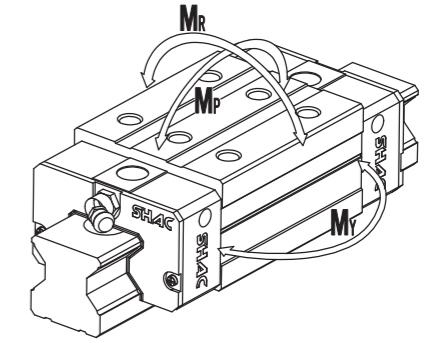
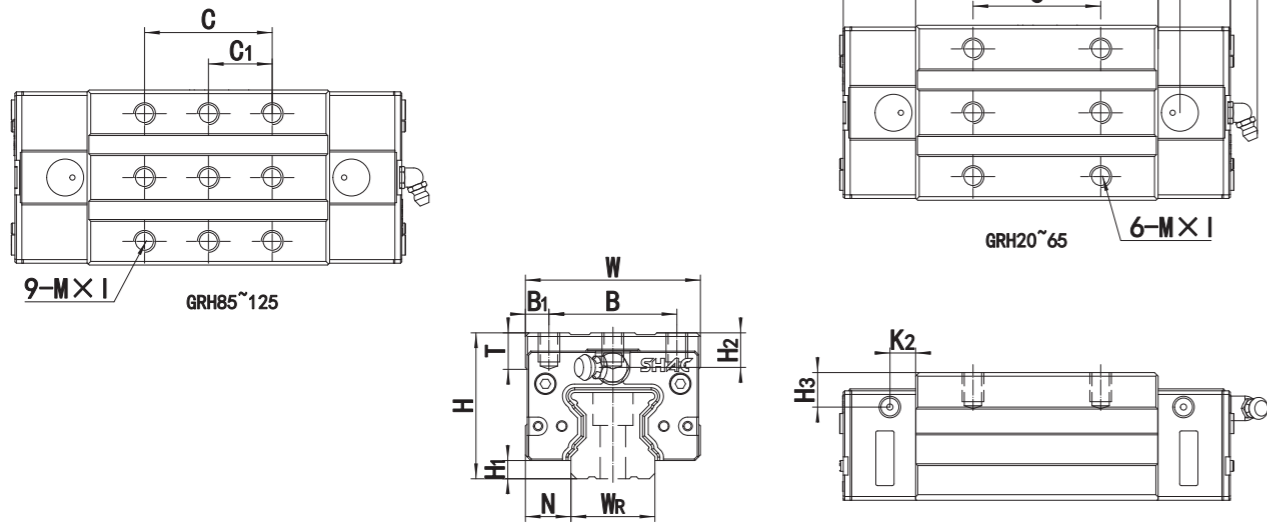

Model No.	Dimensions of Assembly (mm)			Dimensions of Block (mm)													
	H	H ₁	N	W	B	B ₁	C	C ₁	L ₁	L	K ₁	K ₂	G	M*L	T	H ₂	H ₃
GRH20CA	34	5	12	44	32	6	36	-	57.5	86.6	5	4.6	8	M5x8	8.3	8.5	8.5
GRH20HA							50	-	77.5	107							
GRH25SA	40	5	12.5	48	35	6.5	35	-	55.1	96.3	6	7	12	M6x10	10	9.5	9.5
GRH25CA							-	66.5	107.7								
GRH25HA							50	-	83	124.2							
GRH30CA	45	6	16	60	40	10	40	-	71	114	8	8	12	M8x10	9.5	9.5	10.3
GRH30HA							60	-	93	136							
GRH35CA	55	6.5	18	70	50	10	50	-	82	131	8	12	12	M8x14	12	16	16
GRH35HA							72	-	110	159							
GRH45CA	70	8	20.5	86	60	13	60	-	106	158	8	10	13	M10x20	16	20	20
GRH45HA							80	-	142	194							
GRH55CA	80	10	23.5	100	75	12.5	75	-	125.5	182.5	8	12.5	13	M12x20	19	22	22
GRH55HA							95	-	176.5	233.5							
GRH65CA	90	12	31.5	126	76	25	70	-	160	226	16	16	13	M16x20	25	15	15
GRH65HA							120	-	226	292							
GRH85HA	110	15	35.5	156	100	28	140	70	254	349	-	21.5	14	M18x25	30	17	31
GRH100HA	120	15	50	200	130	35	200	100	286	394	-	23	16	M20x27	33	23	37
GRH125HA	160	24.5	57.5	240	184	28	205	102.5	360	491	-	23	16	M24x30	40	30.5	47

1KN=100kgf

Model No.	Dimensions of Rail(mm)								Mounting Bolt for Rail (mm)	Basic Dynamic load Rating C (KN)	Basic Static load Rating C0 (KN)	Static Rated Monent			Weight	
	W _r	H _r	D	h	d	P	E	M _R KN-m				M _P KN-m	M _V KN-m	Block kg	Rail kg/m	
GR20	20	21	9.5	8.5	6	30	20	M5x20	24.05	45.83	0.69	0.466	0.466	0.42	2.55	
									30.34	61.77	0.93	0.846	0.846	0.55		
GR25	23	23.6	11	9	7	30	20	M6x25	28.54	50.21	0.78	0.65	0.65	0.52	3.12	
									33.35	61.37	0.89	0.80	0.80	0.62		
									39.13	75.31	1.12	1.15	1.15	0.76		
GR30	28	28	14	12	9	40	20	M8x30	48.62	81.29	1.8	1.55	1.55	0.9	4.47	
									61.45	109.98	2.05	1.92	1.92	1.13		
GR35	34	30.2	14	12	9	40	20	M8x30	55.14	95.64	2.01	1.22	1.22	1.6	6.13	
									69.63	129.11	2.66	2.3	2.3	2.1		
GR45	45	38	20	17	14	52.5	22.5	M12x35	95.63	178.72	4.5	3.55	3.55	3.15	9.99	
									120.6	240.89	6.55	5.8	5.8	4.09		
GR55	53	44	23	20	16	60	30	M14x45	147.64	255.03	8.2	5.6	5.6	4.8	14.14	
									196.95	369.8	11.25	10.4	10.4	5.75		
GR65	63	53	26	22	18	75.0	35	M16x50	213	411.6	16.2	11.59	11.59	8.57	20.3	
									275.3	572.7	22.55	22.17	22.17	10.52		
GR85	85	73	35	28	24	90	45	M20	460	945.2	51.42	45.6	45.6	14.7	35.2	
GR100	100	80	39	32	26	105	53	M24	547	1330	73.14	61.2	61.2	24.5	46.8	
GR125	125	115	45	45	33	120	60	M30	1040	1924	114.40	123.2	123.2	46	84.6	

1KN=100kgf

GR Series - Roller Linear Guide

(2) GRL-SA / GRL-CA / GRL-HA

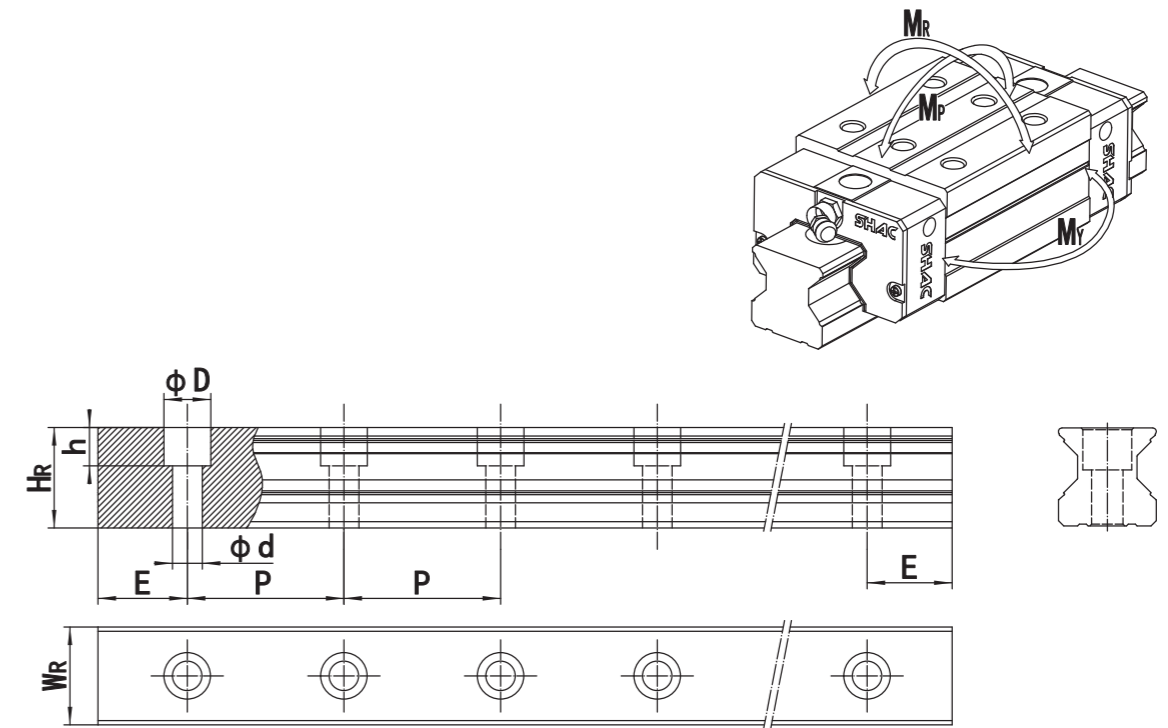
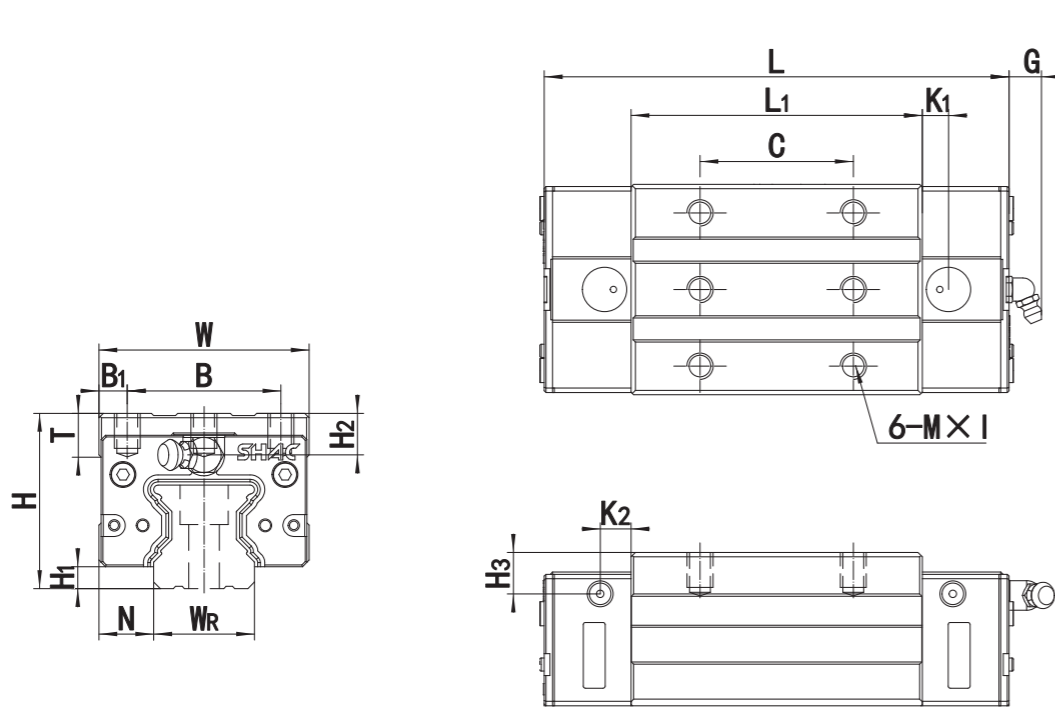

Model No.	Dimensions of Assembly (mm)			Dimensions of Block (mm)												
	H	H ₁	N	W	B	B ₁	C	L ₁	L	K ₁	K ₂	G	M*L	T	H ₃	
GRL25SA	36	5	12.5	48	35	6.5	35	55.1	96.3	6	7	12	M6×10	10	5.5	5.5
GRL25CA							66.5	107.7								
GRL25HA							50	83	124.2							
GRL30CA	42	6	16	60	40	10	40	71	114	8	8	12	M8×10	9.5	6.5	7.3
GRL30HA							60	93	136							
GRL35CA	48	6.5	18	70	50	10	50	82	131	8	12	12	M8×14	12	9	9
GRL35HA							72	110	159							
GRL45CA	60	8	20.5	86	60	13	60	106	158	8	10	13	M10×20	16	10	10
GRL45HA							80	142	194							
GRL55CA	70	10	23.5	100	75	12.5	75	125.5	182.5	8	12.5	13	M12×20	19	12	12
GRL55HA							95	176.5	233.5							

1KN=100kgf

Model No.	Dimensions of Rail(mm)							Mounting Bolt for Rail (mm)	Basic Dynamic load Rating C (KN)	Basic Static load Rating C0 (KN)	Static Rated Moment			Weight	
	W _R	H _R	D	h	d	P	E				M _R KN-m	M _P KN-m	M _Y KN-m	Block kg	Rail kg/m
GR25	23	23.6	11	9	7	30	20	M6×25	28.54	50.21	0.78	0.65	0.65	0.42	3.12
									33.35	61.37	0.89	0.80	0.80	0.50	
									39.13	75.31	1.12	1.15	1.15	0.64	
GR30	28	28	14	12	9	40	20	M8×30	48.62	81.29	1.8	1.55	1.55	0.8	4.47
									61.45	109.98	2.05	1.92	1.92	1.0	
GR35	34	30.2	14	12	9	40	20	M8×30	55.14	95.64	2.01	1.22	1.22	1.3	6.13
									69.63	129.11	2.66	2.3	2.3	1.69	
GR45	45	38	20	17	14	52.5	22.5	M12×35	95.63	178.72	4.5	3.55	3.55	2.46	9.99
									120.6	240.89	6.55	5.8	5.8	3.16	
GR55	53	44	23	20	16	60	30	M14×45	147.64	255.03	8.2	5.6	5.6	3.85	14.14
									196.95	369.8	11.25	10.4	10.4	4.39	

1KN=100kgf

GR Series - Roller Linear Guide

(3) GRW-SC / GRW-CC / GRW-HC

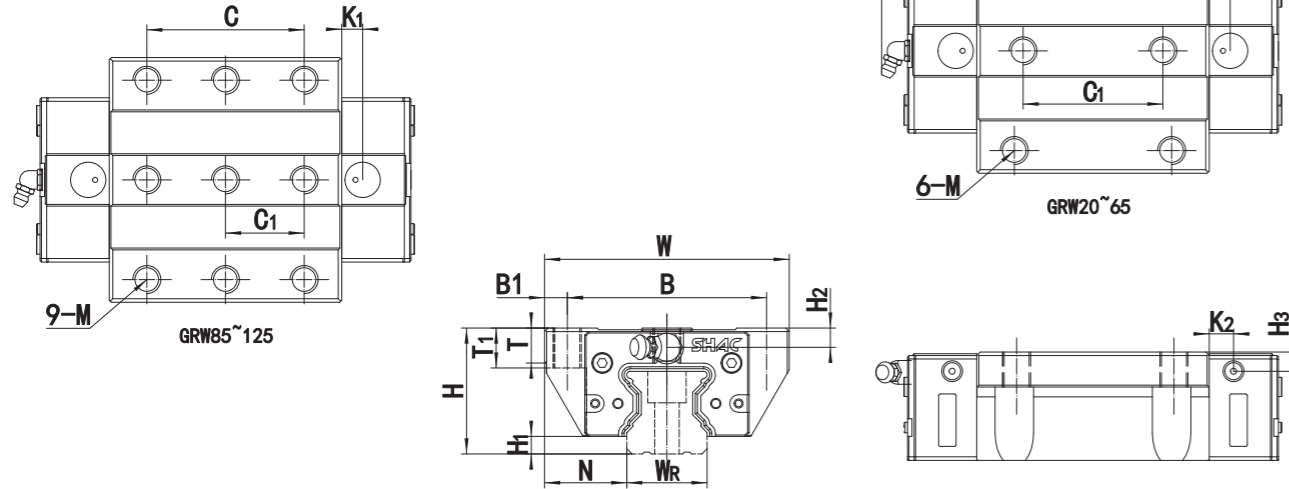

Model No.	Dimensions of Assembly (mm)			Dimensions of Block (mm)														
	H	H ₁	N	W	B	B ₁	C	C ₁	L ₁	L	K ₁	K ₂	G	M	T	T ₁	H ₂	H ₃
GRW20CC	30	5	21.5	63	53	5	40	35	57.5	86.6	5	4.6	8	M6	10	14	4.5	4.5
GRW20HC									77.5	107								
GRW25SC	36	5	23.5	70	57	6.5	45	40	55.1	96.3	6	7	12	M8	10	12.5	5.5	5.5
GRW25CC									66.5	107.7								
GRW25HC									83	124.2								
GRW30CC	42	6	31	90	72	9	52	44	71	114	8	8	12	M10	10	14	6.5	7.3
GRW30HC									93	136								
GRW35CC	48	6.5	33	100	82	9	62	52	82	131	8	12	12	M10	13	13	9	9
GRW35HC									110	159								
GRW45CC	60	8	37.5	120	100	10	80	60	106	158	8	10	13	M12	18	18	10	10
GRW45HC									142	194								
GRW55CC	70	10	43.5	140	116	12	95	70	125.5	182.5	8	12.5	13	M14	18	18	12	12
GRW55HC									176.5	233.5								
GRW65CC	90	12	53.5	170	142	14	110	82	160	226	16	16	13	M16	23	23	15	15
GRW65HC									226	292								
GRW85HC	110	15	65	215	185	15	140	70	254	349	-	21.5	14	M20	24	26	17	31
GRW100HC	120	15	75	250	220	15	200	100	286	394	-	23	16	M20	25	30	23	37
GRW125HC	160	24.5	97.5	320	270	25	205	102.5	360	491	-	23	16	M20	30	45	30.5	47

1KN=100kgf

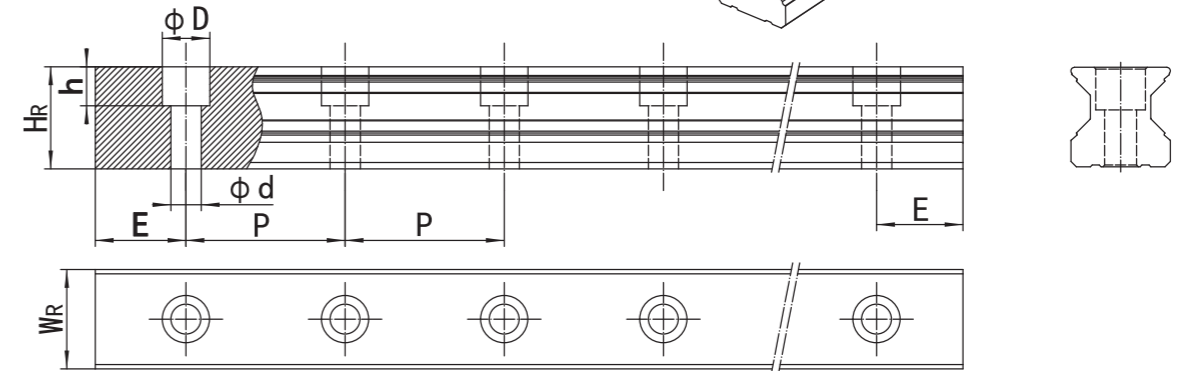
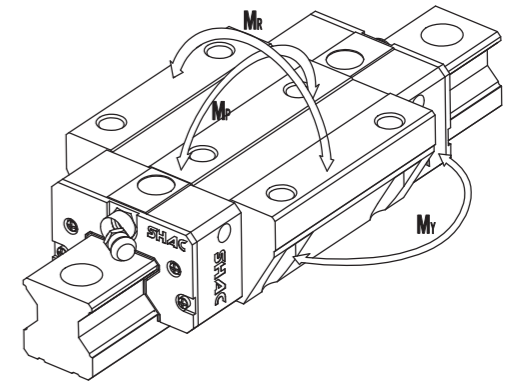

Model No.	Dimensions of Rail(mm)							Mounting Boit for Rail (mm)	Basic Dynamic load Rating C (KN)	Basic Static load Rating C0 (KN)	Static Rated Monent			Weight	
	Wr	Hr	D	h	d	P	E				Mr KN-m	Mp KN-m	Mv KN-m	Block kg	Rail kg/m
GR20	20	21	9.5	8.5	6	30	20	M5x20	24.05	45.83	0.69	0.466	0.466	0.48	2.55
									30.34	61.77	0.93	0.846	0.846	0.64	
GR25	23	23.6	11	9	7	30	20	M6x25	28.54	50.21	0.78	0.65	0.65	0.53	3.12
									33.35	61.37	0.89	0.80	0.80	0.71	
									39.13	75.31	1.12	1.15	1.15	0.87	
GR30	28	28	14	12	9	40	20	M8x30	48.62	81.29	1.8	1.55	1.55	1.11	4.47
									61.45	109.98	2.05	1.92	1.92	1.49	
GR35	34	30.2	14	12	9	40	20	M8x30	55.14	95.64	2.01	1.22	1.22	1.75	6.13
									69.62	129.11	2.66	2.3	2.3	2.37	
GR45	45	38	20	17	14	52.5	22.5	M12x35	95.63	178.72	4.75	3.55	3.55	3.36	9.99
									120.6	240.89	6.55	5.8	5.8	4.55	
GR55	53	44	23	20	16	60	30	M14x45	147.64	255.03	8.2	5.6	5.6	5.2	14.14
									196.95	369.8	11.25	10.4	10.4	7.32	
GR65	63	53	26	22	18	75	35	M16x50	213	411.6	16.2	11.59	11.59	11.3	20.3
									275.3	572.7	22.55	22.17	22.17	13.28	
GR85	85	73	35	28	24	90	45	M20	460	945.2	51.42	45.6	45.6	21.6	35.2
GR100	100	80	39	32	26	105	53	M24	547	1330	73.14	61.2	61.2	31.5	46.8
GR125	125	115	45	45	33	120	60	M30	1040	1924	114.40	123.2	123.2	65.5	84.6

1KN=100kgf

GR series - Roller Linear guide (rail with protective cover strip)

(4) GRH-SA-S / GRH-CA-S / GRH-HA-S

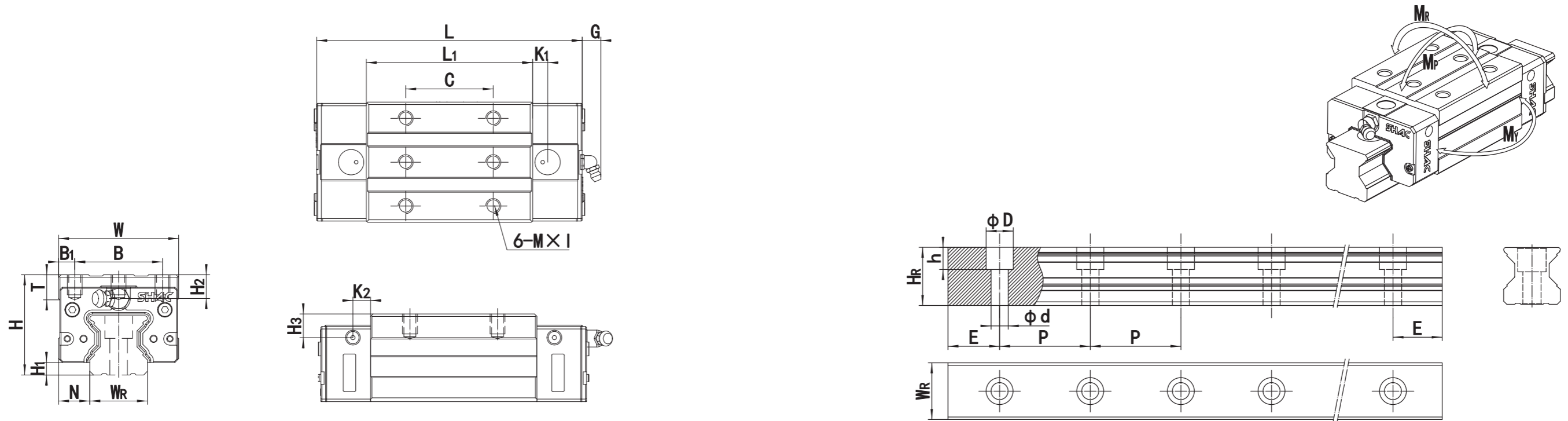

Model No.	Dimensions of Assembly (mm)			Dimensions of Block (mm)													
	H	H ₁	N	W	B	B ₁	C	C ₁	L ₁	L	K ₁	K ₂	G	M*L	T	H ₂	H ₃
GRH25SA-S	40	5	12.5	48	35	6.5	35	-	55.1	96.3	6	7	12	M6×10	10	9.5	9.5
GRH25CA-S							-	66.5	107.7								
GRH25HA-S							50	-	83	124.2							
GRH30CA-S	45	6	16	60	40	10	40	-	71	114	8	8	12	M8×10	9.5	9.5	10.3
GRH30HA-S							60	-	93	136							
GRH35CA-S	55	6.5	18	70	50	10	50	-	82	131	8	12	12	M8×14	12	16	16
GRH35HA-S							72	-	110	159							
GRH45CA-S	70	8	20.5	86	60	13	60	-	106	158	8	10	13	M10×20	16	20	20
GRH45HA-S							80	-	142	194							

1KN=100kgf

Model No.	Dimensions of Rail(mm)							Mounting Boit for Rail (mm)	Basic Dynamic load Rating C (KN)	Basic Static load Rating C0 (KN)	Static Rated Monent			Weight	
	W _R	H _R	D	h	d	P	E				M _R KN-m	M _P KN-m	M _V KN-m	Block kg	Rail kg/m
GR25	23	23.6	11	9	7	30	20	M6×25	28.54	50.21	0.78	0.65	0.65	0.52	3.12
									33.35	61.37	0.89	0.80	0.80	0.62	
									39.13	75.31	1.12	1.15	1.15	0.76	
GR30	28	28	14	12	9	40	20	M8×30	48.62	81.29	1.8	1.55	1.55	0.9	4.47
									61.45	109.98	2.05	1.92	1.92	1.13	
GR35	34	30.2	14	12	9	40	20	M8×30	55.14	95.64	2.01	1.22	1.22	1.6	6.13
									69.63	129.11	2.66	2.3	2.3	2.1	
GR45	45	38	20	17	14	52.5	22.5	M12×35	95.63	178.72	4.5	3.55	3.55	3.15	9.99
									120.6	240.89	6.55	5.8	5.8	4.09	

1KN=100kgf

GR series - Roller Linear guide (rail with protective cover strip)

(5) GRW-SC-S / GRW-CC-S / GRW-HC-S

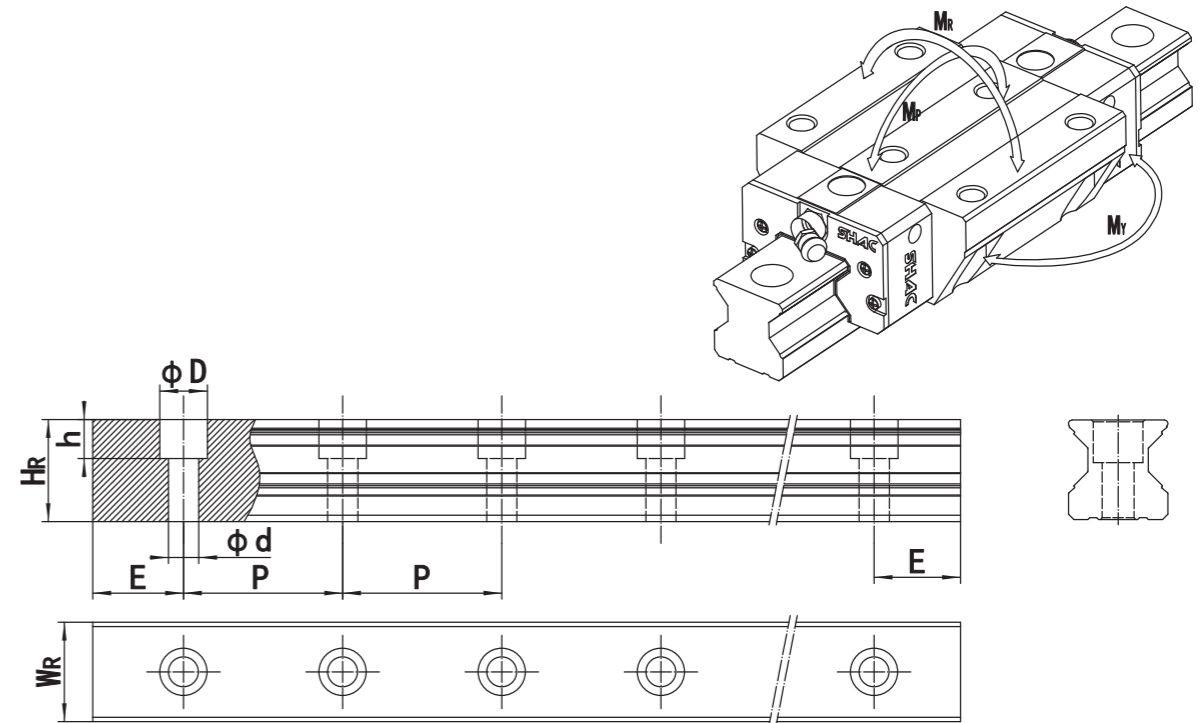
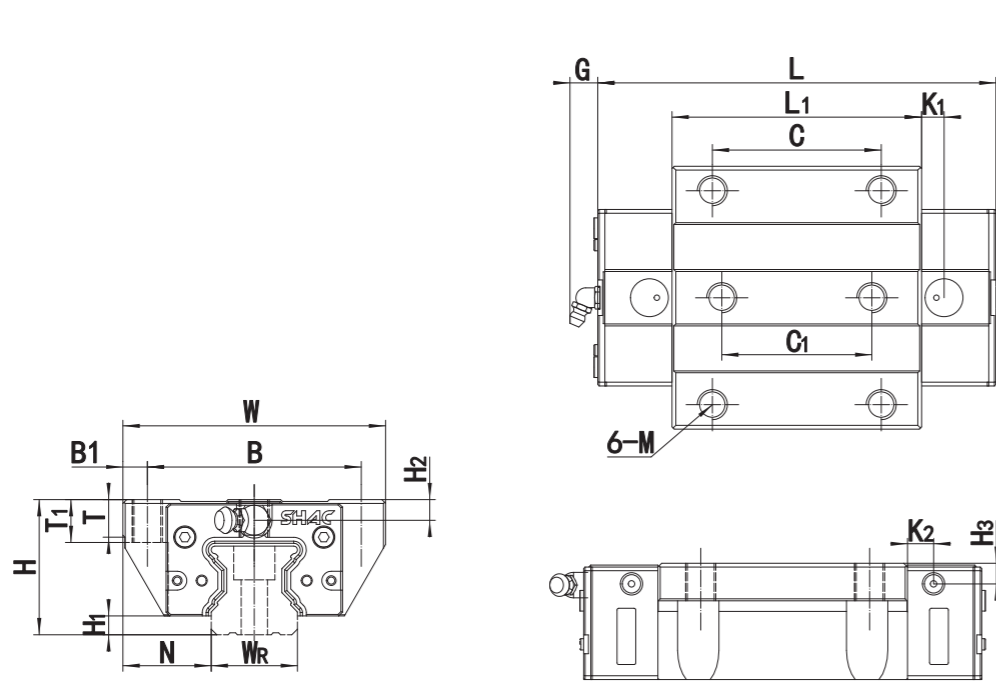

Model No.	Dimensions of Assembly (mm)			Dimensions of Block (mm)														
	H	H ₁	N	W	B	B ₁	C	C ₁	L ₁	L	K ₁	K ₂	G	M	T	T ₁	H ₂	H ₃
GRW25CS-S	36	5	23.5	70	57	6.5	45	40	55.1	96.3	6	7	12	M6	10	13	5.5	5.5
GRW25CC-S									66.5	107.7								
GRW25HC-S									83	124.2								
GRW30CC-S	42	6	31	90	70	9	52	44	71	114	8	8	12	M10	9.5	14	7.3	7.3
GRW30HC-S									93	136								
GRW35CC-S	48	6.5	33	100	82	9	62	52	82	131	8	12	12	M10	12	13	9	9
GRW35HC-S									110	159								
GRW45CC-S	60	5	37.5	120	100	10	80	60	106	158	8	10	13	M12	16	18	10	10
GRW45HC-S									142	194								

1KN=100kgf

Model No.	Dimensions of Rail(mm)							Mounting Boit for Rail (mm)	Basic Dynamic load Rating C (KN)	Basic Static load Rating C ₀ (KN)	Static Rated Monent			Weight	
	W _r	H _r	D	h	d	P	E				M _r KN-m	M _p KN-m	M _v KN-m	Block kg	Rail kg/m
GR25	23	24	11	9	7	30	20	M6×25	28.54	50.21	0.78	0.65	0.65	0.53	3.12
									33.35	61.37	0.89	0.80	0.80	0.64	
									39.13	75.31	1.12	1.15	1.15	0.71	
GR30	28	28	14	12	9	40	20	M8×30	48.62	81.29	1.8	1.55	1.55	1.11	4.47
									61.45	109.98	2.05	1.92	1.92	1.49	
GR35	34	30	14	12	9	40	20	M8×30	55.14	95.64	2.01	1.22	1.22	1.75	6.13
									69.63	129.11	2.66	2.3	2.3	2.37	
GR45	45	38	20	17	14	52.5	22.5	M12×35	95.63	178.72	4.5	3.55	3.55	3.36	9.99
									120.6	240.89	6.55	5.8	5.8	4.55	

1KN=100kgf

2-7 GMN Series - Miniature Ball Linear Guide

Product Features

The GMN series adopts a sophisticated design with a 2-column Gothic raceway structure and a 45 degree contact angle, making it characterized by miniaturization, lightweight, and low friction resistance. It has the same load capacity in all directions and has good walking smoothness and low noise, making it particularly suitable for use in miniaturized equipment

Product structure

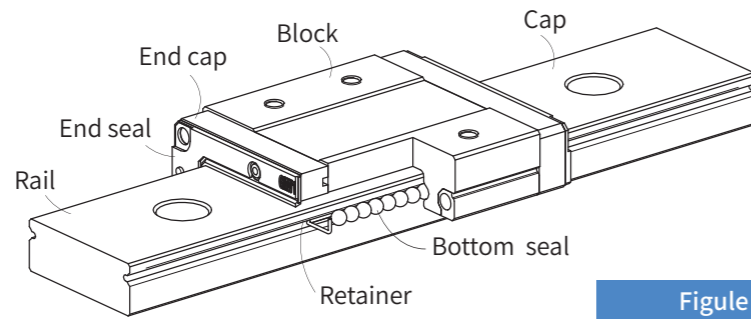

Figure 2-6-1

Rolling cycle system: slider Guide rails, end caps, ball bearings, and retainers

Lubrication system: GMN15 is designed with a fuel nozzle, while GMN7,9 and 12 are designed with fuel holes that can inject lubricant into the interior of the slider

Dust prevention system: dust sheet, dust strip (optional for 9, 12, 15 specifications), cover (available for 12, 15 specifications)

Product Features

The GMW series adopts a sophisticated design with a 2-column Gothic raceway structure and a 45 degree contact angle, making it characterized by miniaturization, lightweight, and low friction resistance. It has the same load capacity in all directions and has good walking smoothness and low noise. The wide rail width design has high rigidity and large load capacity in terms of lateral torque, making it suitable for single axis use

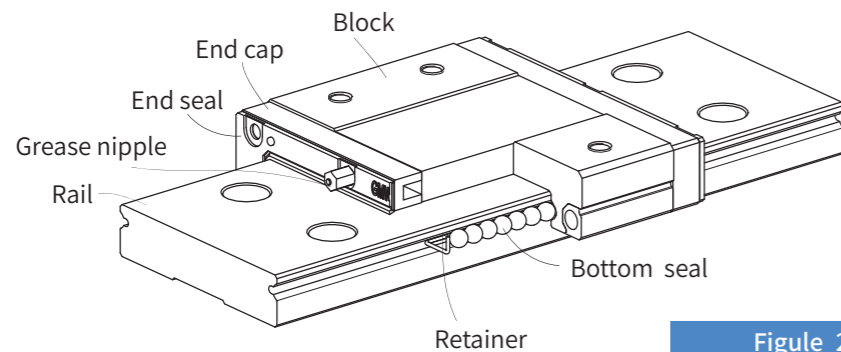

Figure 2-6-2

Rolling cycle system: slider Guide rails, end caps, ball bearings, and retainers

Lubrication system: GMW15 is designed with a fuel nozzle, while GMW7, 9, and 12 are designed with fuel holes that can inject lubricant into the interior of the slider

Dust prevention system: dust sheet, dust strip (optional for 9, 12, 15 specifications), cover (available for 12, 15 specifications)

2-7-1 GMN Series - Miniature Ball Linear Guide

Recommended applicable equipment

High precision light load: micro medical equipment, small electronic instruments, chip equipment, pneumatic component applications, etc

Table 2-6-1

Item	Product advantages	Corresponding efficiency
1	Two column Gothic raceway	Simple structure has high stability under stress (GMW series has higher dynamic and static loads and moments)
2	45 degree contact angle	Maximum force contact structure with optimal load capacity
3	Small and lightweight	The simplest combination of rails and blocks creates the minimum application space capability
4	Low friction resistance	The combination of a two column structure and a minimal contact area at a 45 degree angle results in extremely low friction performance
5	Four directions with the same load	The same load capacity characteristics in all directions make design and use more convenient
6	Smooth and low noise	Excellent smooth performance provides the possibility of special applications

2-7-2 GM series product types

Table 2-6-2

Style	Specification	SHAPE	Height dimension (mm)	Guide rail length (mm)	Equipment suitable for application
Square	GMN-C GMN-H		8	100	● Printer ● Mechanical arm ● Electronic instruments ● Semiconductor equipment
			10 13 16	↓ 2000	
Flange	GMW-C GMW-H		9	100	
			12 14	↓ 6000	
Wide width type	GMW-C GMW-H		16	100 ↓ 6000	

2-7-3 Product model of non-interchangeable linear guide rail

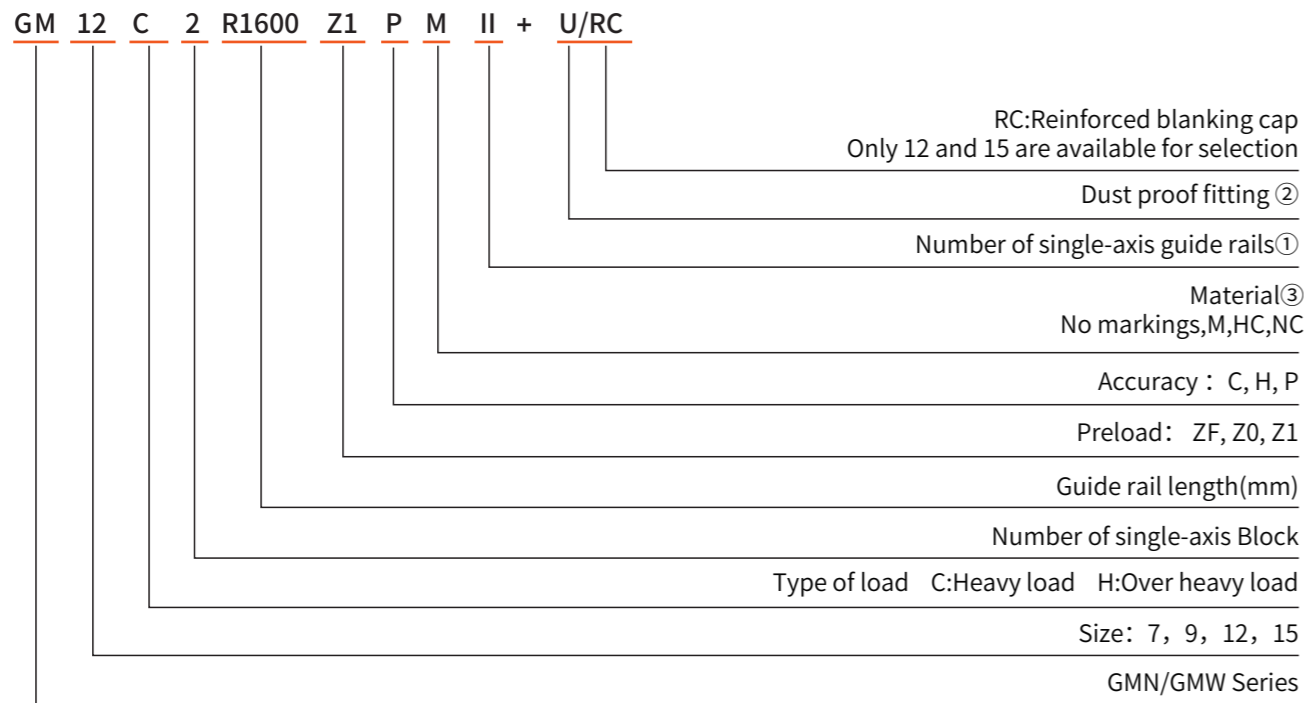

Note:

1. If only one single axis guide rail is used, the number of guide rails is not written. When two are used, it is marked as II, when three are used, it is marked as III, and so on
2. GMN and GMW specifications 9, 12, 15 can be equipped with dust-proof sheets
3. unmarked: general steel material, M: stainless steel material HC: general steel material+ hard chrome plating NC: general steel material+chemical black chrome

2-7-4 Product model of interchangeable linear guide rail (sliding block)

Model of slider products shipped separately

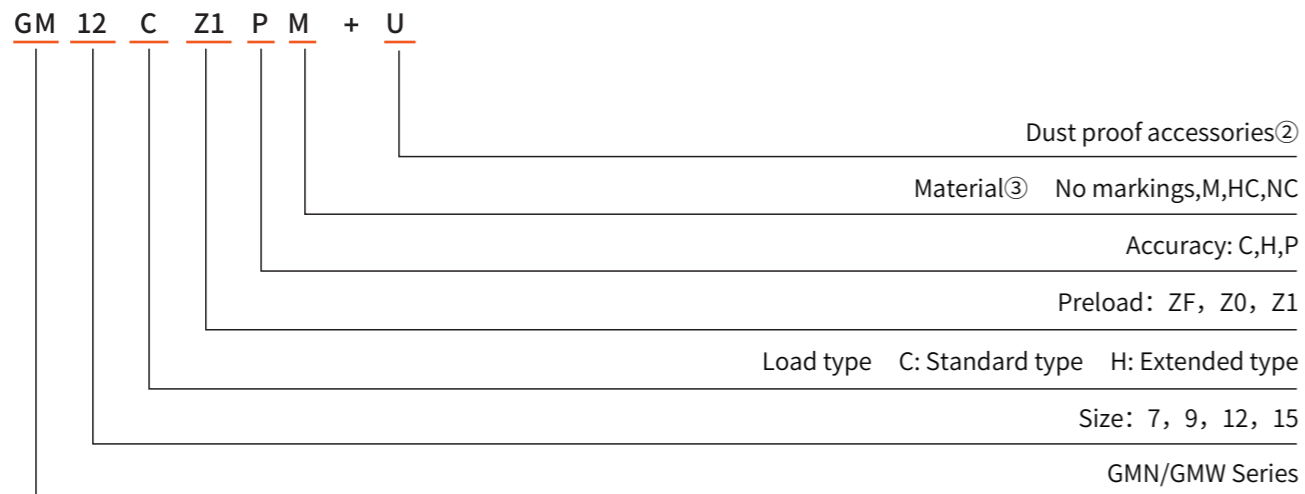

Note: GM only has an external reflux module design

Model of rail products shipped separately

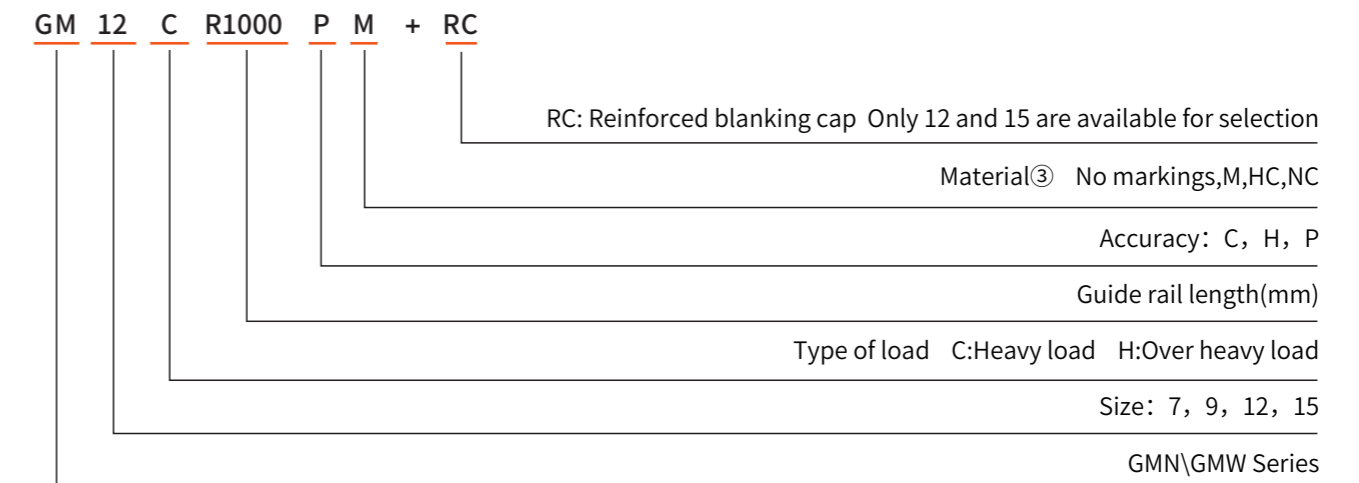

Grade of Accuracy

The precision of the GM series linear guide rail can be divided into three levels: ordinary level, advanced level, and precision level. Customers can choose the corresponding level of products according to their equipment precision requirements

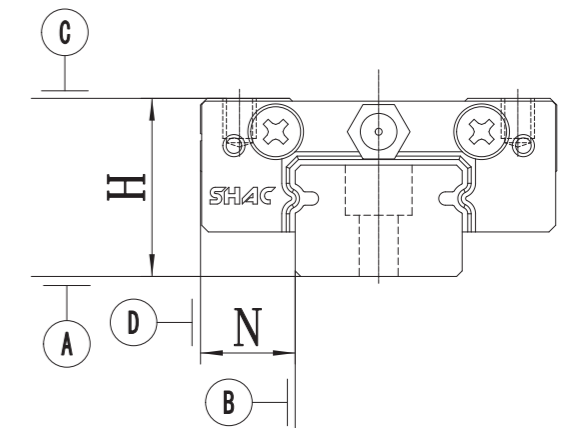

Figure 2-6-3

2-7-5 Accuracy of non interchangeable linear guides

Table 2-6-3 Assembly accuracy table

Unit : mm

Grade of accuracy	Precision Level (P)	High Level (H)	Ordinary Level (C)
Allowable dimension error of height H	±0.01	±0.02	±0.04
Allowable error of width N	±0.015	±0.025	±0.04
Mutual error of paired width H	0.007	0.015	0.03
Allowable error of paired width N	0.01	0.02	0.03
Traveling parallelism of slide block C to A of guide rail	Travel parallelism (see Table 2-6-5)		
Traveling parallelism of slide block D to B of guide rail			

2-7-6 Accuracy of interchangeable linear guide rail

Table 2-6-4 Single Output Accuracy Table

Unit : mm

Grade of accuracy	Precision Level (P)	High Level (H)	Ordinary Level (C)
Allowable dimension error of height H	±0.01	±0.02	±0.04
Allowable error of width N	±0.015	±0.025	±0.04
Mutual error of paired width H	0.007	0.015	0.03
Allowable error of paired width N	0.01	0.02	0.03
Mutual error of height H in multiple pairs	0.02	0.04	0.07
Traveling parallelism of slide block C to A of guide rail	Travel parallelism (see Table 2-6-5)		
Traveling parallelism of slide block D to B of guide rail			

2-7-7 Traveling parallel precision

Table 2-6-5

Guide rail length (mm)	Grade of accuracy (μm)			Guide rail length (mm)	Grade of accuracy (μm)		
	P	H	C		P	H	C
50以下	2	6	12	1000~1200	11	18	25
50~80	3	7	13	1200~1300	11	18	25
80~125	3.5	8	14	1300~1400	12	19	26
125~200	4	9	15	1400~1500	12	19	27
200~250	5	10	16	1500~1600	13	20	28
250~315	5	11	17	1600~1700	14	20	29
315~400	6	11	18	1700~1800	14	21	30
400~500	6	12	19	1800~1900	15	21	30
500~630	7	13	20	1900~2000	15	22	31
630~800	8	14	22	2000~	16	22	31
800~1000	9	16	23				

2-7-8 Preload

The so-called preloading refers to increasing the diameter of the steel ball to create a negative gap between the steel ball and the groove, and applying a load to the interior in advance. By using preloading assembly, not only can gaps be eliminated, but the rigidity and walking accuracy of the slider can also be improved. The GM series offers three preloading options: normal clearance, no preloading, and light preloading.

Grade of preload

Table 2-6-6 Grade of preload

Preload	Marking	Preloading amount	Applicable accuracy
Normal clearance	ZF	4~10μm	C
No preload	Z0	0	C-P
Light preload	Z1	0.02C	C-P

Note: Pre pressure C is the dynamic rated load

Dust proof accessories

The standard dust-proof accessory is equipped with dust-proof sheets at both ends of the slider and dust-proof strips at the bottom of the slider to prevent dust or foreign objects from entering the slider and affecting the life and accuracy of the linear guide. Only specifications 9, 12, and 15 can be equipped with dust-proof strips.

If customers want to use dust-proof strips, they can add the code U after the model. It is important to note that the gap (H) between the sliders will decrease when using dust-proof strips to avoid interference with the side bearing surface during operation.

Table 2-6-7 After installing the dust strip, the gap between the slider is H1

Model	Bottom seal	H _i (mm)	Model	Bottom seal	H _i (mm)
GM7	-	-	GM7	-	-
GM9	●	1	GM9	●	1.9
GM12	●	2	GM12	●	2.4
GM15	●	3	GM15	●	2.4

Allowable error of installation surface

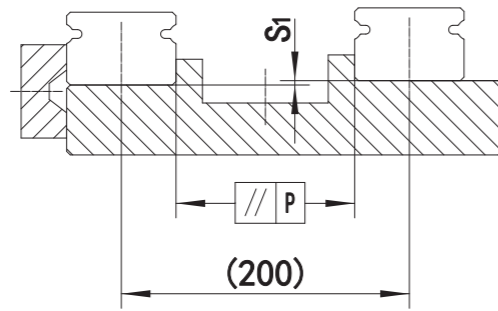

Figure 2-6-4

Table 2-6-8 Maximum allowable parallelism error (P)

Unit : mm

Specification	Grade of preload		
	ZF	Z0	Z1
GM7	3	3	3
GM9	4	4	3
GM12	9	9	5
GM15	10	10	6

Table 2-6-9 Table Allowable error in water level (S_a)

Unit : mm

Specification	Grade of preload		
	ZF	Z0	Z1
GM7	25	25	3
GM9	35	35	6
GM12	50	50	12
GM15	60	60	20

Note: The allowable value is proportional to the distance between the two guide rail supports

Table 2-6-10 Flatness of installation surface

Specification	Flatness error
GM7	0.025/200
GM9	0.035/200
GM12	0.050/200
GM15	0.060/200

Note: The above values are for the preloading level of a single ZF/Z0. If using Z1 level or two or more guide rails (including two), it is recommended to use less than 50% of the above values

2-7-9 Installation precautions

(1) Bearing surface height and guide angle

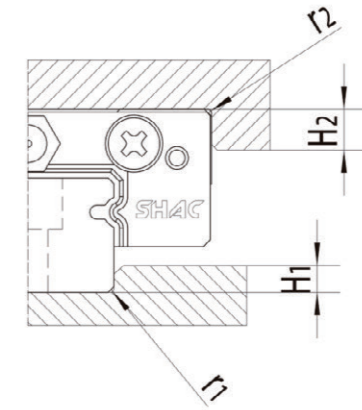

Figure 2-6-5

Table 2-6-11 Bearing surface height and guide angle

Specification	Maximum rounded corner at the end of the guide rail r_1 (mm)	Maximum rounded corner at slider end r_2 (mm)	Height of guide rail bearing surface H_1 (mm)	Height of slider bearing H_2 (mm)	Chamfer dimensions for linear guide
					A/B
GMN7	0.2	0.2	1.2	3	0.2
GMN9	0.2	0.3	1.7	3	0.3
GMN12	0.3	0.4	1.7	4	0.4
GMN15	0.5	0.5	2.5	5	0.5
GMW7	0.2	0.2	1.7	3	0.3
GMW9	0.3	0.3	2.5	3	0.3
GMW12	0.4	0.4	3	4	0.4
GMW15	0.4	0.8	3	8	0.5

Specification and torque value of guide rail installation screws

The locking force of the linear guide rail installation directly affects the service life and accuracy of the guide rail, so it is important to use a torque wrench to lock each screw with the appropriate torque value

Table 2-6-12 Torque value

Specification	Screw specification	Torque value N-cm (kgf-cm)		
		Iron parts	casting	aluminum alloy
GMN7	M2×0.4P×6L	57 (5.9)	39.2 (4)	29.4 (3)
GMN9	M3×0.5P×8L	186 (19)	127 (13)	98 (10)
GMN12	M3×0.5P×8L	186 (19)	127 (13)	98 (10)
GMN15	M3×0.5P×10L	186 (19)	127 (13)	98 (10)
GMW7	M3×0.5P×6L	186 (19)	127 (13)	98 (10)
GMW9	M3×0.5P×8L	186 (19)	127 (13)	98 (10)
GMW12	M4×0.7P×8L	392 (40)	274 (28)	206 (21)
GMW15	M4×0.7P×10L	392 (40)	274 (28)	206 (21)

Note : 1kgf=9.81 N

2-7-10 Standard length and maximum length of a single guide rail

We will prepare a certain quantity of standard length guide rail inventory. If you want to customize non-standard length guide rails, it is best not to have the end distance E greater than 1/2 of the hole distance. Excessive end distance can cause instability at the rear end of the guide rail installation, affecting the accuracy of the linear guide rail.

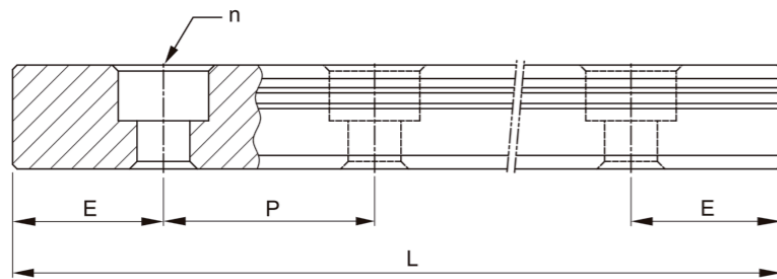

Figure 2-6-6

$$L = (n-1) \times P + 2 \times E$$

- L: Total length of guide rail (mm)
- n: Number of installation holes
- P: Hole spacing (mm)
- E: End distance (mm)

Table 2-6-13 Length of Rail

Unit: μm

Item	GMNR7	GMNR9	GMNR12	GMNR15	GMWR7	GMWR9	GMWR12	GMWR15
Standard length L (n)	40 (3)	55 (3)	70 (3)	70 (2)	80 (3)	80 (3)	110 (3)	110 (3)
	55 (4)	75 (4)	95 (4)	110 (3)	110 (4)	110 (4)	150 (4)	150 (4)
	70 (5)	95 (5)	120 (5)	150 (4)	140 (5)	140 (5)	190 (5)	190 (5)
	85 (6)	115 (6)	145 (6)	190 (5)	170 (6)	170 (6)	230 (6)	230 (6)
	100 (7)	135 (7)	170 (7)	230 (6)	200 (7)	200 (7)	270 (7)	270 (7)
	130 (9)	155 (8)	195 (8)	270 (7)	260 (9)	230 (8)	310 (8)	310 (8)
		175 (9)	220 (9)	310 (8)		260 (9)	350 (9)	350 (9)
		195 (10)	245 (10)	350 (9)		290 (10)	390 (10)	390 (10)
		275 (14)	270 (11)	390 (10)		350 (14)	430 (11)	430 (11)
		375 (19)	320 (13)	430 (11)		500 (19)	510 (13)	510 (13)
			370 (15)	470 (12)		710 (24)	590 (15)	590 (15)
			470 (19)	550 (14)		860 (29)	750 (19)	750 (19)
			570 (23)	670 (17)			910 (23)	910 (23)
		695 (28)	870 (22)			1070 (27)	1070 (27)	
Hole spacing (P)	15	20	25	40	30	30	40	40
End distance (E _s)	5	7.5	10	15	10	10	15	15
Maximum length of standard end distance	595 (40)	1195 (60)	1995 (80)	1990 (50)	590 (20)	1970 (66)	1990 (50)	1990 (50)
Max. length	600	1200	2000	2000	600	2000	2000	2000

Note:

1. The general tolerance for the distance between guide rail ends is 0.5~0.5m, while the strict tolerance for the distance between guide rail ends on the street is 0~0.3mm
2. The maximum length of the standard end distance refers to the maximum length of the guide rail where both the left and right end distances are the standard end distance
3. The maximum length of GMNR9 stainless steel guide rail is 1200mm, while the maximum length of GMNR9 general steel guide rail is 1000mm
4. The maximum length of GMWR7 stainless steel guide rail is 600mm, while the maximum length of GMWR7 general steel guide rail is 2000mm
5. If the customer requires end distances of different sizes, please contact SHAC

GM Series - Miniature Ball Linear Guides (injection structure type)

(1) GMN-C / GMN-H

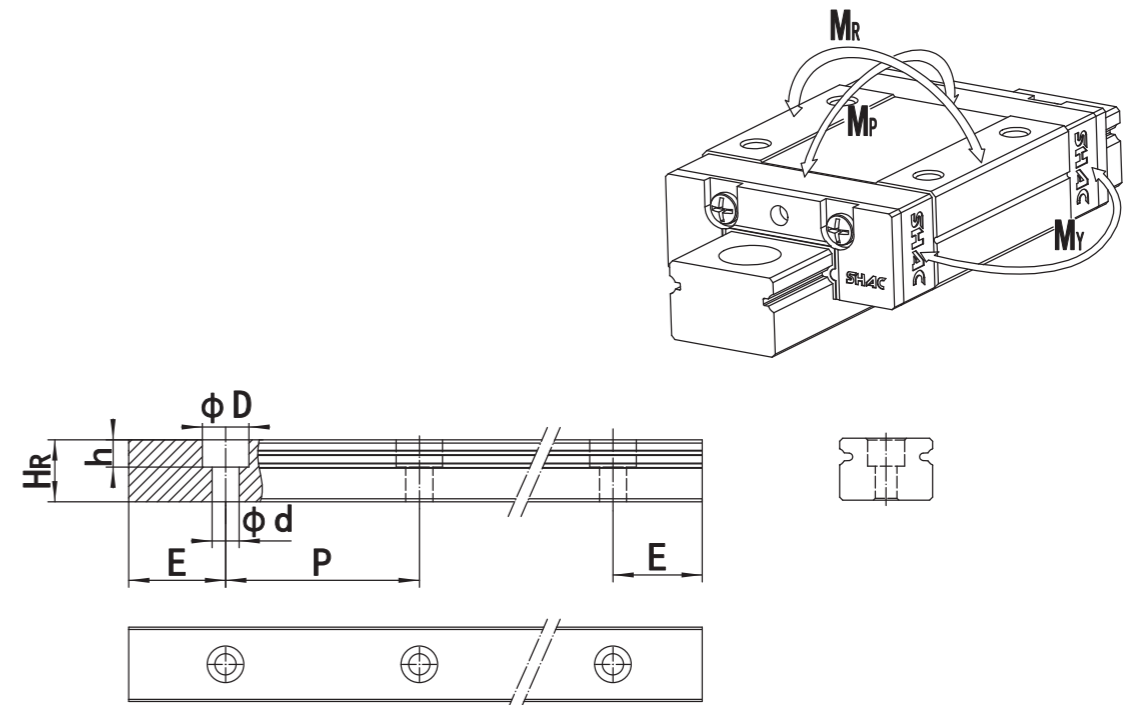
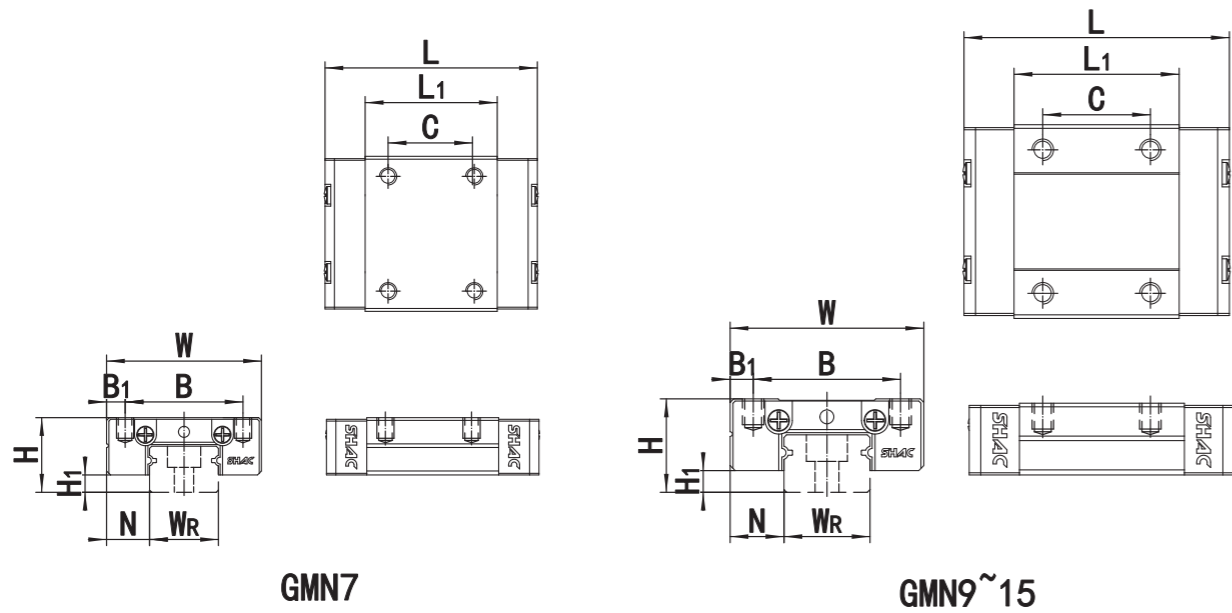

Model No.	Dimensions of Assembly (mm)			Dimensions of Block (mm)									
	H	H ₁	N	W	B	B ₁	C	L ₁	L	G	Gn	M*L	H ₃
GMN7C	8	1.5	5	17	12	2.5	8	13.5	22.5	-	φ1.2	M2×2.5	1.5
GMN7H							13	21.8	30.8				
GMN9C	10	2	5.5	20	15	2.5	10	19	28.9	-	φ1.4	M3×3	1.8
GMN9H							16	30	39.9				
GMN12C	13	3	7.5	27	20	3.5	15	22.4	34.6	-	φ2	M3×3.5	2.5
GMN12H							20	33.2	45.4				
GMN15C	16	4	8.5	32	25	3.5	20	26.5	42	4.5	M3	M3×4	3
GMN15H							25	43	58.5				

1KN=100kgf

Model No.	Dimensions of Rail(mm)							Mounting Bolt for Rail (mm)	Basic Dynamic load Rating C (KN)	Basic Static load Rating C ₀ (KN)	Static Rated Moment			Weight	
	W _R	H _R	D	h	d	P	E				M _R N-m	M _P N-m	M _V N-m	Block kg	Rail kg/m
GMN7	7	5	4.2	2.3	2.4	15	5	M2×6	1.45	1.88	5.3	3.01	3.01	0.01	0.23
									1.87	2.46	7.9	5.02	5.02	0.013	
GMN9	9	6.5	6	3.5	3.5	20	7.5	M3×8	2.47	3.36	12.05	7.64	7.64	0.015	0.39
									3.52	5.61	20.3	19.43	19.43	0.023	
GMN12	12	8	6	4.5	3.5	25	10	M3×8	3.58	4.77	27.61	15.44	15.44	0.033	0.66
									4.87	7.42	40.33	38.75	38.75	0.045	
GMN15	15	10	6	4.5	3.5	40	15	M3×10	5.36	7.21	48.13	26.54	26.54	0.055	1.08
									7.44	11.54	76.58	60.49	60.49	0.085	

1KN=100kgf

GM Series - Miniature Ball Linear Guides (injection structure type)

(2) GMW-C / GMW-H

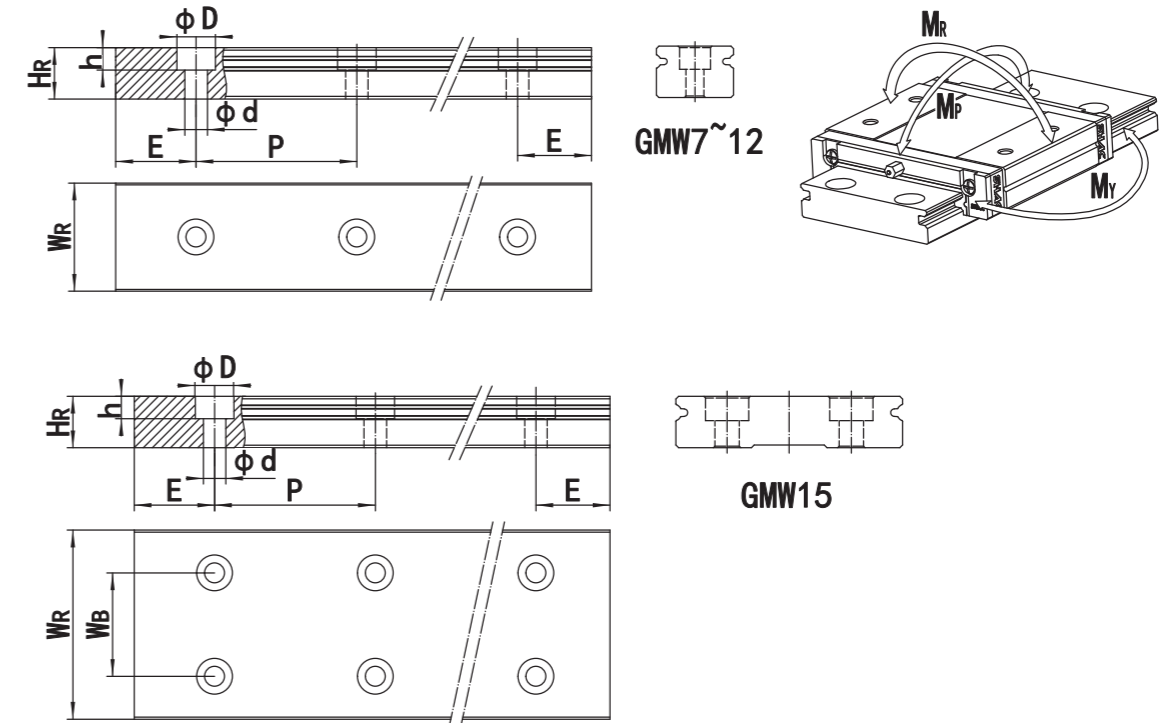
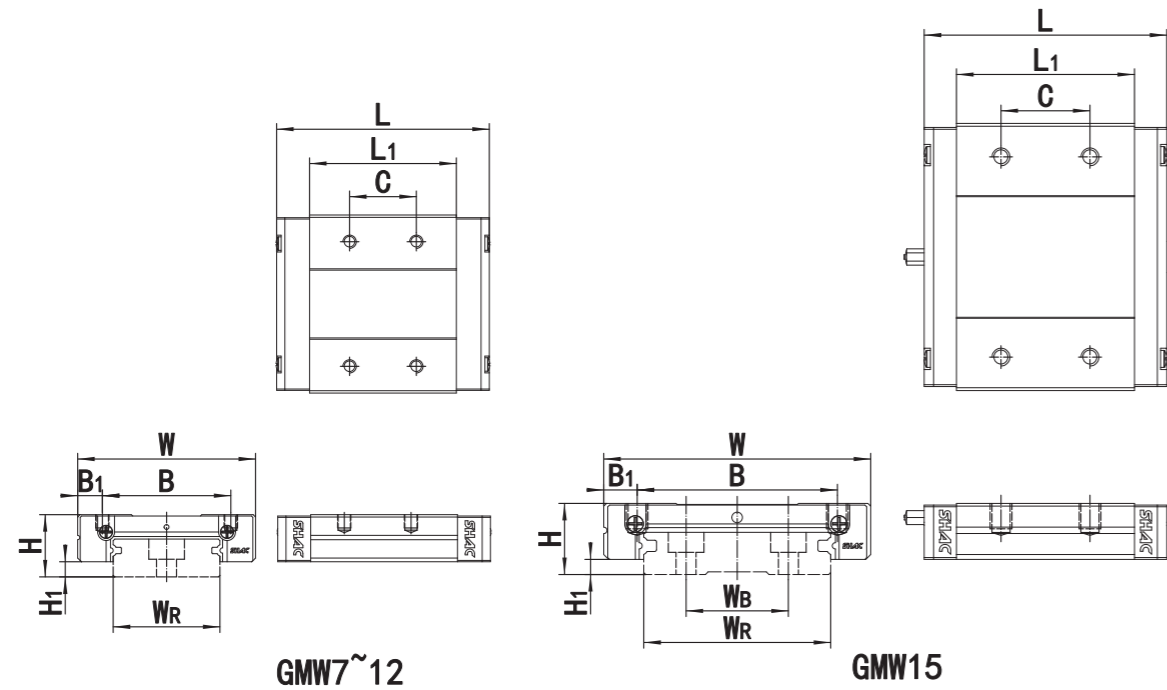

Model No.	Dimensions of Assembly (mm)			Dimensions of Block (mm)									
	H	H ₁	N	W	B	B ₁	C	L ₁	L	G	Gn	M*L	H ₃
GMW7C	9	1.9	5.5	25	19	3	10	21	31.2	-	φ1.2	M3×3	1.85
GMW7H							19	30.8	41				
GMW9C	12	2.9	6	30	21	4.5	12	27.5	39.1	-	φ1.2	M3×3	2.4
GMW9H					23	3.5	24	38.5	50.1				
GMW12C	14	3.4	8	40	28	6	15	33	45.6	-	φ1.2	M3×3.6	2.8
GMW12H							28	46	58.6				
GMW15C	16	3.4	9	60	45	7.5	30	40	54	5.0	M3	M4×4.2	3.2
GMW15H							35	59.8	73.8				

1KN=100kgf

Model No.	Dimensions of Rail(mm)								Mounting Bolt for Rail (mm)	Basic Dynamic load Rating C (KN)	Basic Static load Rating C0 (KN)	Static Rated Moment			Weight	
	W _R	W _B	H _R	D	h	d	P	E				M _R N-m	M _P N-m	M _V N-m	Block kg	Rail kg/m
GMW7	14	-	5.2	6	3.2	3.5	30	10	M3×6	1.87	2.56	16.9	8.25	8.25	0.019	0.52
										2.28	3.65	26.77	18.56	18.56	0.024	
GMW9	18	-	7	6	4.5	3.5	30	10	M3×8	3.36	5.23	42.65	20.11	20.11	0.038	0.92
										4.31	7.47	60.11	38.1	38.1	0.055	
GMW12	24	-	8.5	8	4.5	4.5	40	15	M4×8	4.63	6.89	75.33	30.21	30.21	0.065	1.5
										6.03	10.06	105.8	60.4	60.4	0.09	
GMW15	42	23	9.5	8	4.5	4.5	40	15	M4×10	8.09	11.3	200.56	60.42	60.42	0.14	2.88
										10.74	16.95	310.5	130.6	130.6	0.20	

1KN=100kgf

2-8 WE Series Wide-Format Ball Linear Guide

The WE Series features a four-row ball bearing design to handle steel loads. With a 45-degree contact angle, it offers four-way equal load distribution and self-aligning capabilities, accommodating mounting surface assembly errors to achieve high precision. Simultaneously, it increases the line model size while reducing the assembly height, achieving ultra-high torsional resistance. In environments with space constraints or where high torque is required, it can be used as a single-axis solution.

Product Structure :

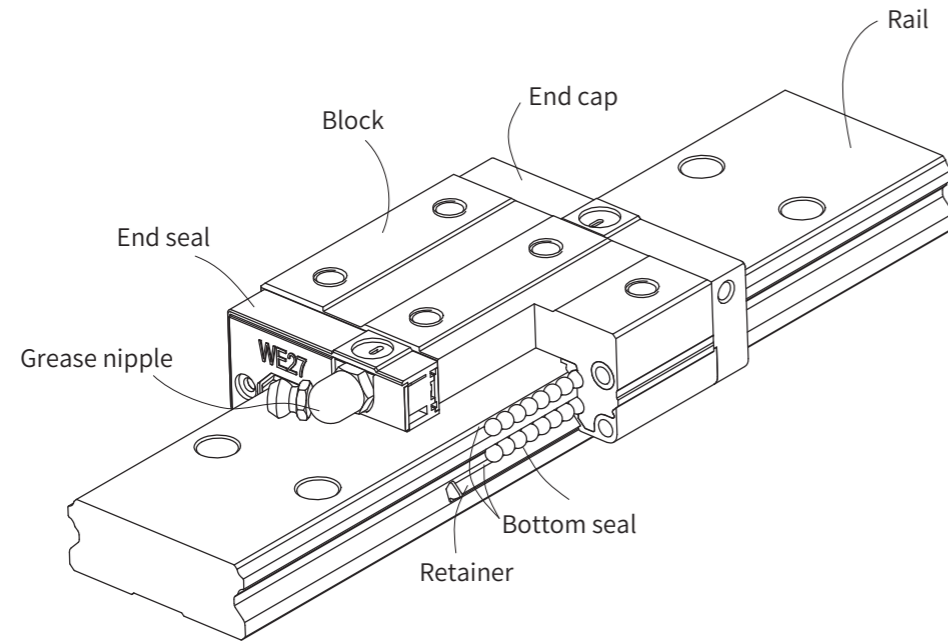

Figure 2-7-1

Rolling Circulation System:

Slider, Guide Rail, End Cover, Steel Ball, Steel Ball Retainer

Lubrication System:

Oil Nozzle, Oil Pipe Connector

Dust Protection System:

Oil Scraper Plate, Bottom Dust Seal Plate, Guide Rail Bolt Cover, Metal Scraper

2-8-1 Product model of non-interchangeable linear guide

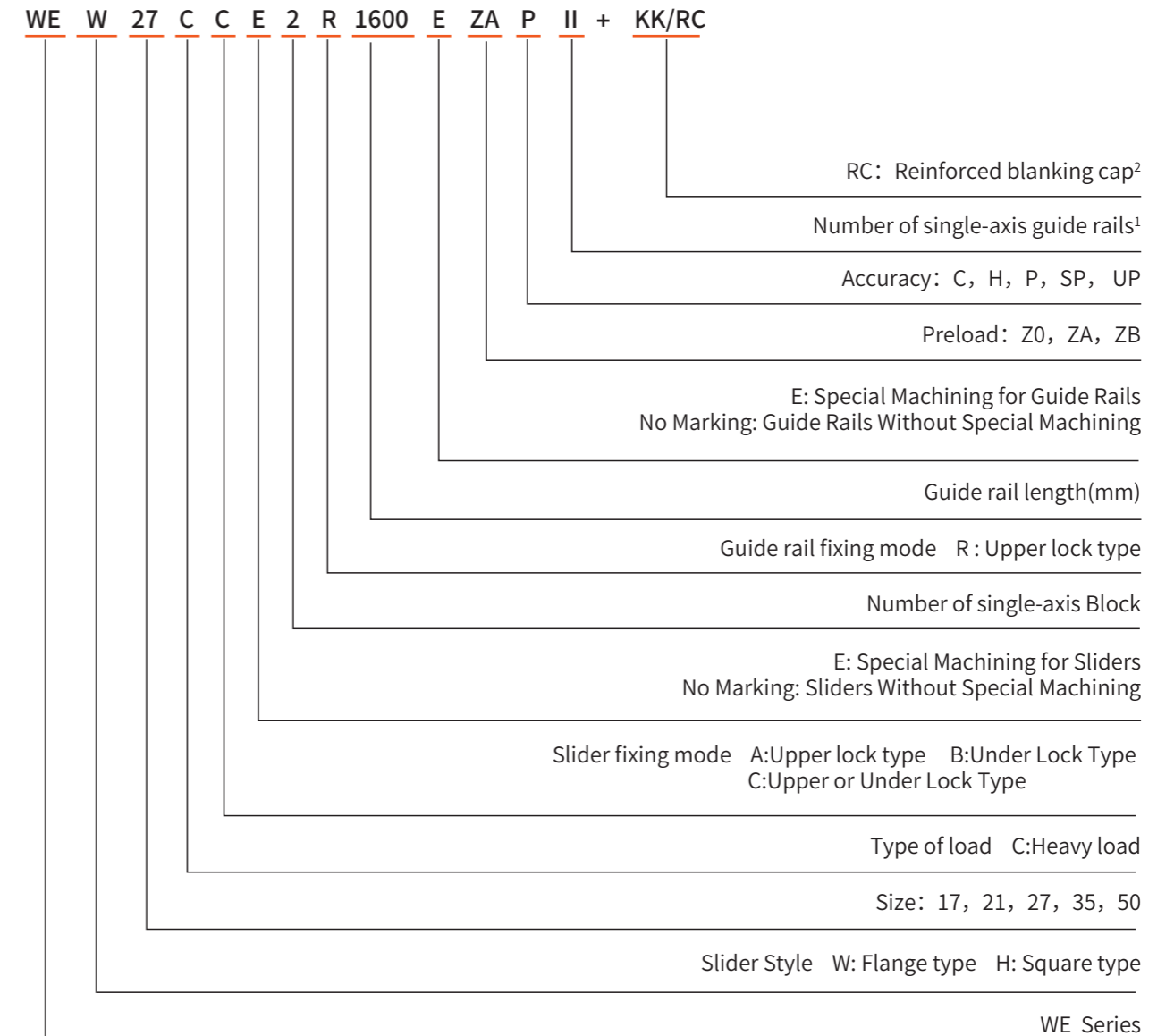

Note:

1. The number of single-axis guide rails shall not be written if only — support guide rails are used. Two guide rails are marked as II, three guide rails are marked as III, and so on.

2. The dust proof accessories with several weights are standard dust proof accessories with dust strip.

ZZ: dust strip, dust strip and metal scraper.

KK is double dust proof, dust strip and metal scraper.

DD DUAL DUST FINS WITH DUST STRIPS.

The sliding block type L is the low assembled sliding block of square type H, and the combined height is consistent with the flange type of the same size.

2-8-2 Interchangeable Linear Guide Product Models

Product model of interchangeable linear guide sliding block

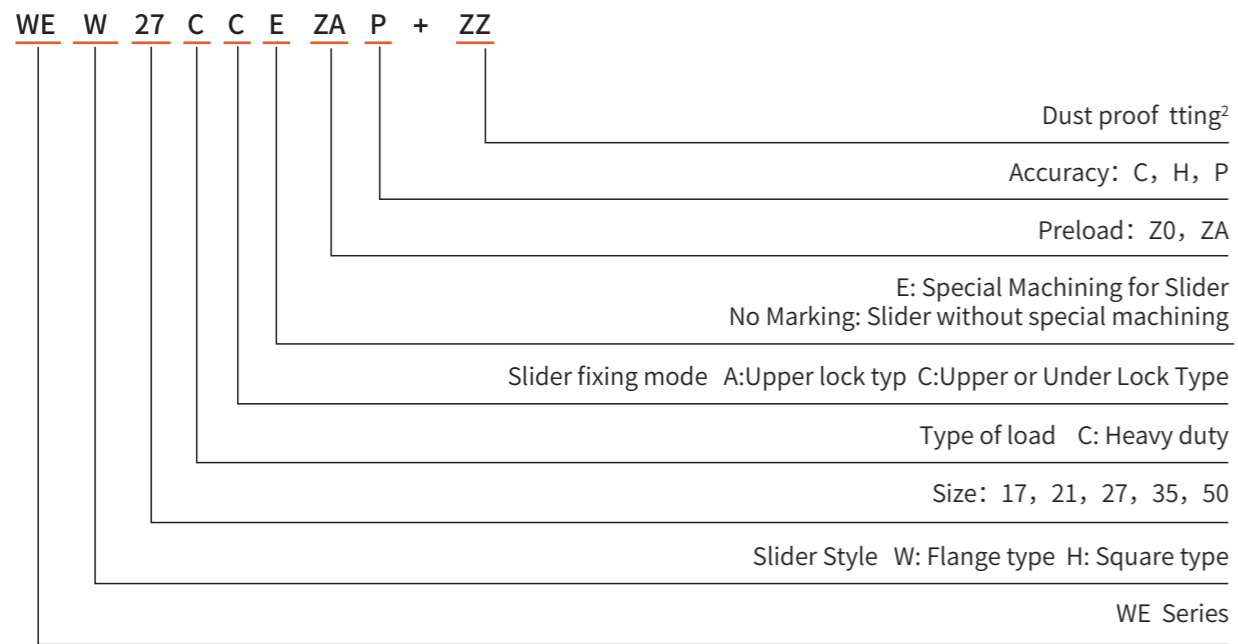

Interchangeable linear guide rail (guide rail) product model

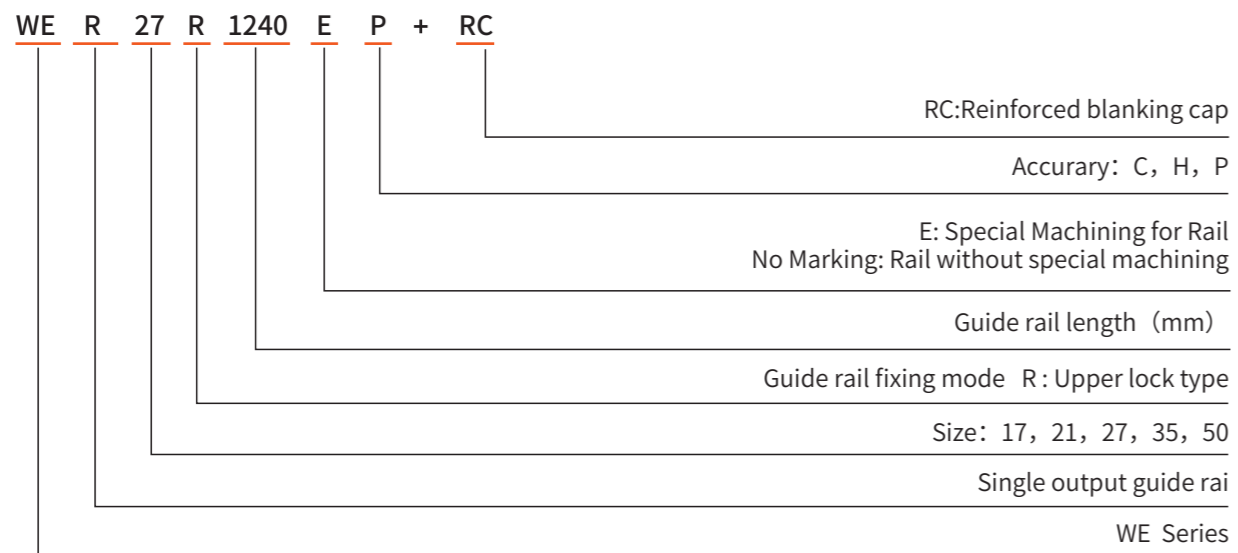

2-8-3 WE series slide block type

Table 2-7-1 Block Type

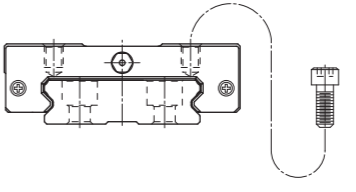
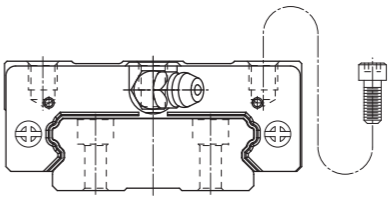
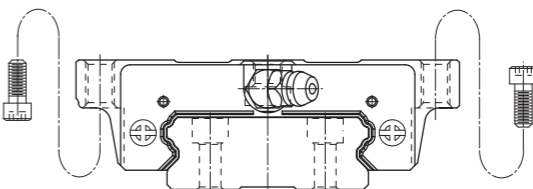
Style	Model No.	Shape	Height dimension (mm)	Guide rail length (mm)	Equipment suitable for application
Square	WEH-CA 17, 21		17 ↓ 21	100 ↓ 4000	<ul style="list-style-type: none"> ● Precision adding machine ● Mechanical machining ● Heavy duty cutting machine ● Marble cutting machine ● Tools and machines ● Measuring instruments ● Grinding machine ● Punch press ● Ejecting machine ● Automation device ● Transport equipment
Square	WEH-CA 27, 35, 50		27 ↓ 50	100 ↓ 4000	
Flange	WEW-CC		17 ↓ 50	100 ↓ 4000	

Guide rail fixing mode

Upper locking screw hole guides

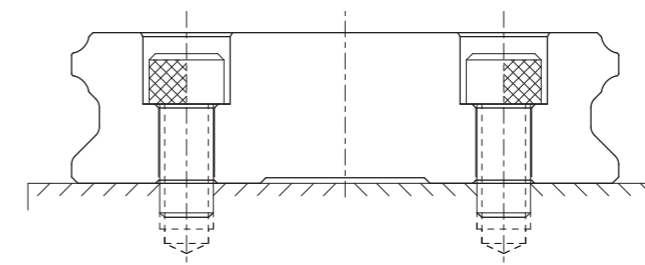
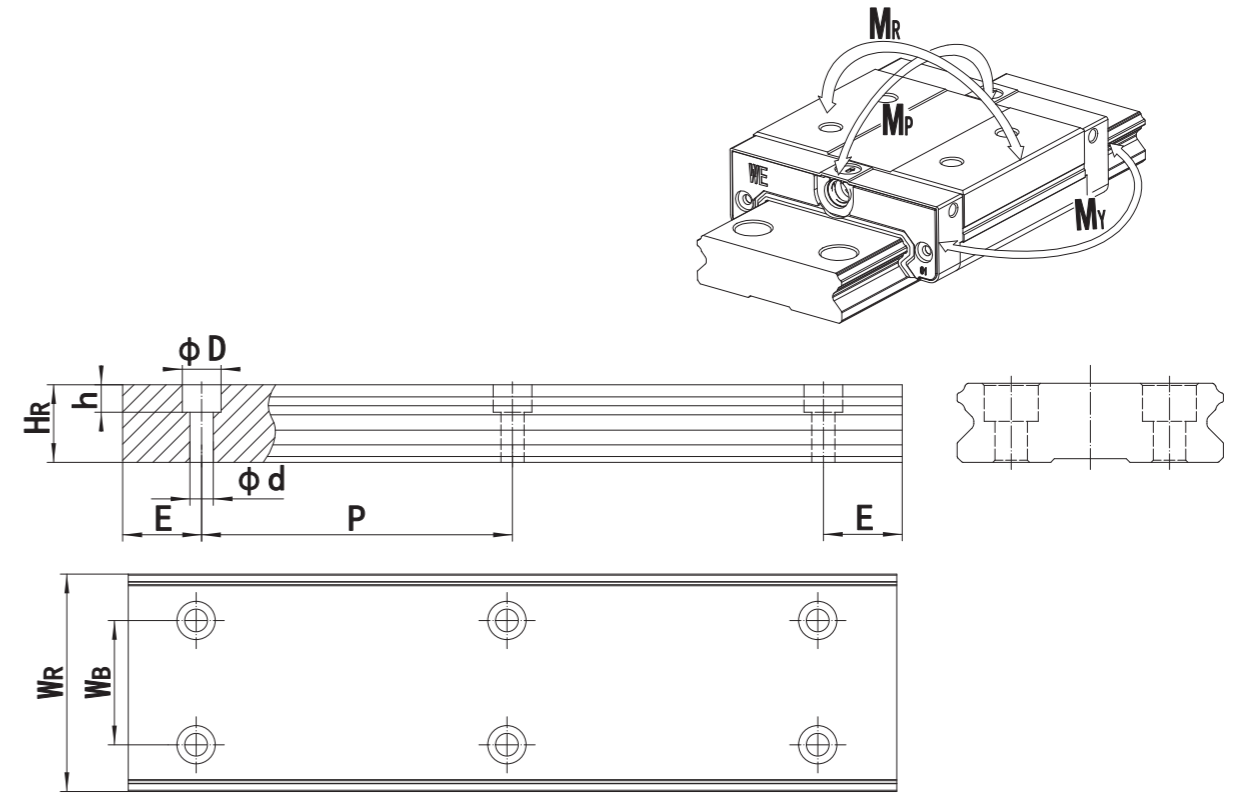
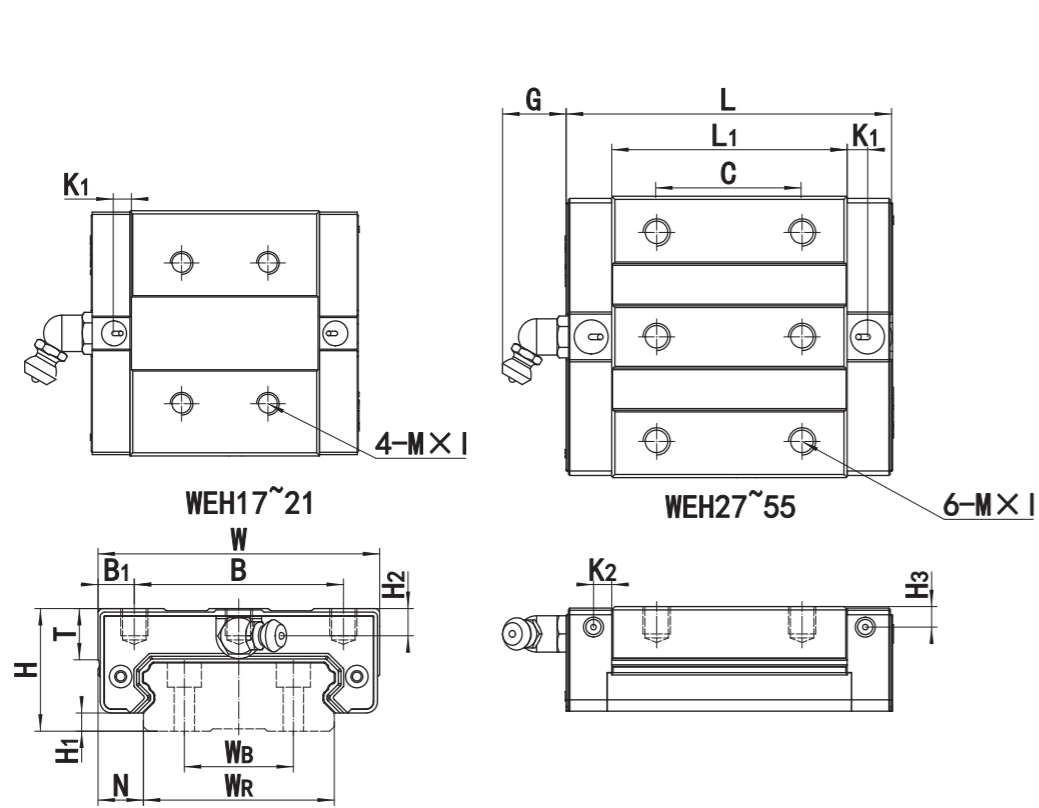

Figure 2-7-2

WE Series Wide-Format Ball Linear Guide

(1) WEH-CA



Model No.	Dimensions of Assembly (mm)			Dimensions of Block (mm)												
	H	H ₁	N	W	B	B ₁	C	L ₁	L	K ₁	K ₂	G	M*L	T	H ₂	H ₃
WEH17CA	17	2.5	8.5	50	29	10.5	15	35	51	-	3.1	4.9	M4×5	4	4	
WEH21CA	21	3	8.5	54	31	11.5	19	41.7	58.7	3.5	3.2	12	M5×6	8	4.5	3
WEH27CA	27	4	10	62	46	8	32	51.8	71.8	4.5	4	12	M6×6	11	6	4.5
WEH35CA	35	4	15.5	100	76	12	50	77.6	102.6	4.3	5	12	M8×8	13	8	6.5
WEH50CA	50	7.5	20	130	100	15	65	112	140	4.5	6	12.9	M10×15	19.5	12	10.5

1kgf=9.81N

Model No.	Dimensions of Rail(mm)								Mounting Boit for Rail (mm)	Basic Dynamic load Rating C (KN)	Basic Static load Rating C ₀ (KN)	Static Rated Monent			Weight	
	W _R	W _B	H _R	D	h	d	P	E				M _R N-m	M _P N-m	M _V N-m	Block kg	Rail kg/m
WE17	33	18	9.3	7.5	5.3	4.5	40	15	M4×12	5.16	9.66	0.14	0.05	0.05	0.11	2.1
WE21	37	22	11	7.5	5.3	4.5	50	25	M4×12	7.18	13.83	0.22	0.09	0.09	0.21	2.9
WE27	42	24	15	7.5	5.3	4.5	60	20	M4×16	12.3	21.56	0.41	0.16	0.16	0.34	4.6
WE35	69	40	19	11	9	7	80	20	M6×20	29.5	49.63	1.47	0.66	0.66	1.15	9.5
WE50	90	60	24	14	12	9	80	20	M8×25	61.3	96.82	4.01	1.94	1.94	3.1	14.4

1kgf=9.81N

WE Series Wide-Format Ball Linear Guide

(2) WEW-CC

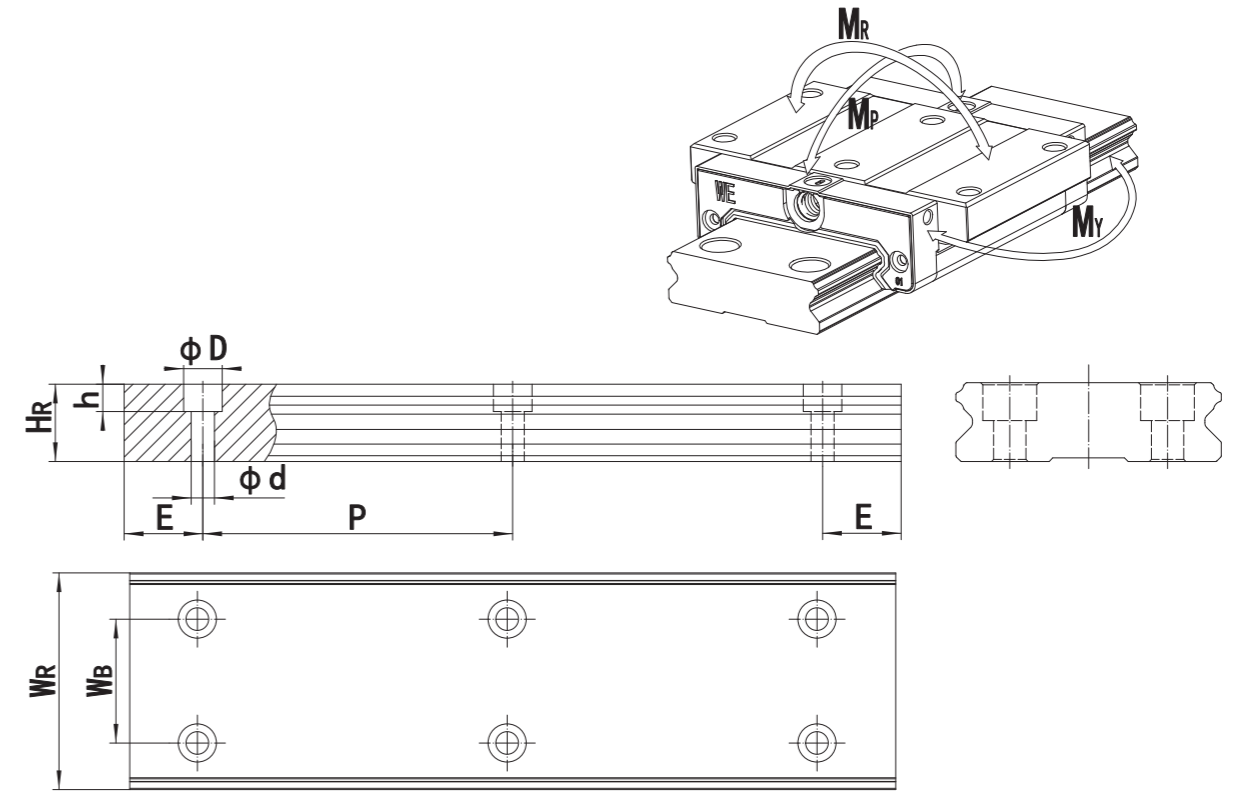
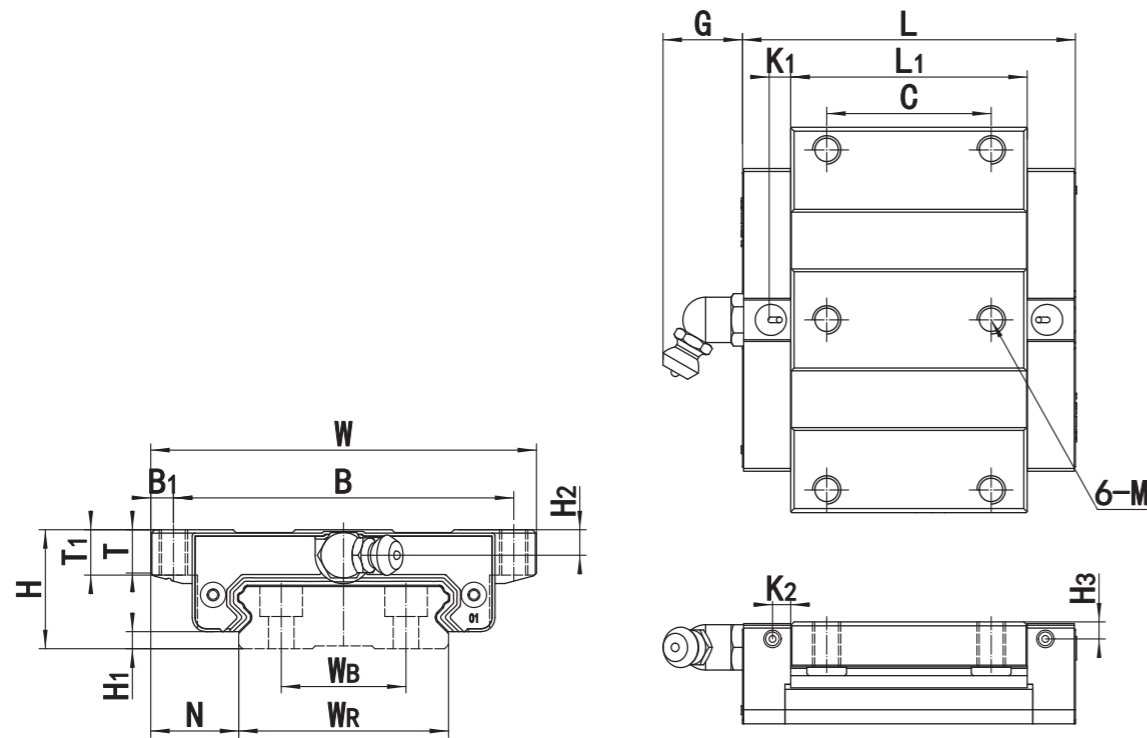

Model No.	Dimensions of Assembly (mm)			Dimensions of Block (mm)													
	H	H ₁	N	W	B	B ₁	C	L ₁	L	K ₁	K ₂	G	M	T	T ₁	H ₂	H ₃
WEW17CC	17	2.5	13.5	60	53	3.5	26	35	51	-	-	4.6	M4	5.3	6	4	3
WEW21CC	21	3	15.5	68	60	4	29	41.7	58.7	3.5	3.2	12	M5	7.6	8	4.5	3
WEW27CC	27	4	19	80	70	5	40	51.8	71.8	4.5	4	12	M6	8	10	6	4.5
WEW35CC	35	4	25.5	120	107	6.5	60	77.6	102.6	4.3	5	12	M8	11	14	8	6.5
WEW50CC	50	7.5	36	162	144	9	80	112	140	4.5	6	12	M10	14	18	12	10.5

1kgf=9.81N

Model No.	Dimensions of Rail(mm)								Mounting Boit for Rail (mm)	Basic Dynamic load Rating C (KN)	Basic Static load Rating C0 (KN)	Static Rated Monent			Weight	
	W _r	W _B	H _r	D	h	d	P	E				MR N-m	MP N-m	MY N-m	Block kg	Rail kg/m
WE17	33	18	9.3	7.5	5.3	4.5	40	15	M4×12	5.16	9.66	0.14	0.05	0.05	0.12	2.1
WE21	37	22	11	7.5	5.3	4.5	50	25	M4×12	7.18	13.83	0.22	0.09	0.09	0.22	2.9
WE27	42	24	15	7.5	5.3	4.5	60	20	M4×16	12.3	21.56	0.41	0.16	0.16	0.42	4.6
WE35	69	40	19	11	9	7	80	20	M6×20	29.5	49.63	1.47	0.66	0.66	1.24	9.5
WE50	90	60	24	14	12	9	80	20	M8×25	61.3	96.82	4.01	1.94	1.94	3.6	14.4

1kgf=9.81N

3 Clamp

3-1 Structure and Function

The clamping device consists of components such as the main body, actuator element, clamping element, and contact element. It serves as a high-performance functional component paired with rolling linear guide rails, offering functions including workbench securing, precise positioning, vibration damping, and enhanced rigidity.

3-2 Purpose

Position holding can be applied to any position of linear guideway and linear axes. It maintains position during sudden circumstances such as power outages to prevent falling and enhance equipment safety. By increasing the rigidity of the mechanical structure, it prevents deformation, oscillations, and vibrations. It can be powered by compressed air for automated positioning applications.

3-3 Advantage

Normally Open

It features a fixed workbench positioning to prevent vibration and enhance rigidity.

By enhancing the rigidity of the structure, production efficiency is improved.

- Horizontal lathe: prevent the tailstock from tilting
- Mobile multi-joint robot: prevent vibration of the robotic arm

Achieve the fixation of mechanism position, miniaturization, and low cost.

- Aluminum window frame processing machine: fixed drill position, vibration isolation
- Slitter: The blade position is fixed

Brake type

- Prevent falling and provide braking effect; miniaturize to enhance safety
- Machining center: emergency stop of linear motor drive axis

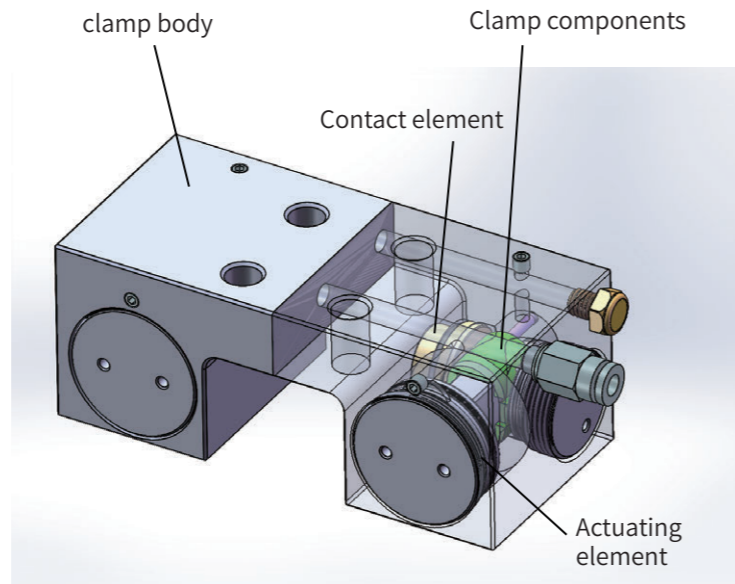

Figure 1-1-1



Figure 1-1-2

3-4 Principle

Using compressed air as the power source, and leveraging the wedge block force amplification principle, a transmission structure capable of maintaining operation under a significant clamping force for a period of time and thus exhibiting force amplification characteristics becomes particularly important.

To ensure the front-end device has sufficiently stable performance, it is recommended to regularly check whether the connections between devices and pipes are secure.

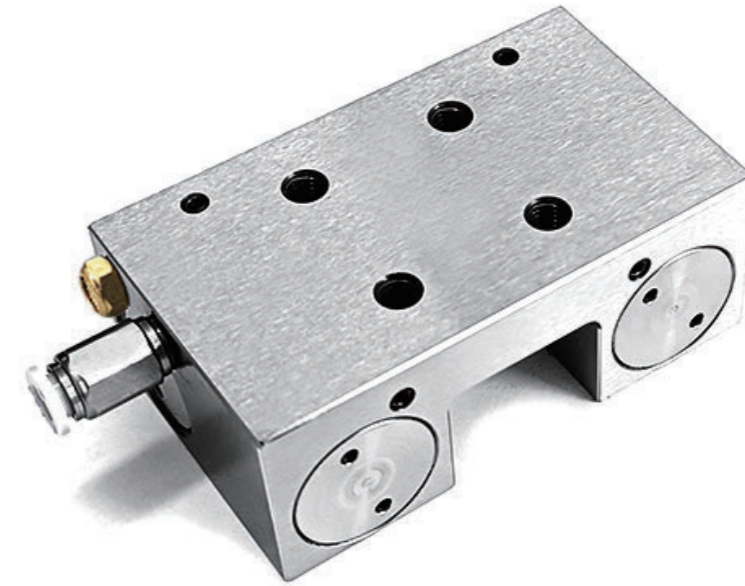

Figure 1-1-3

The guide rail clamp is a high-performance functional component used in conjunction with the linear guide rail pair.



Figure 1-1-4

QK Series - Pneumatic Normally Open Clamp

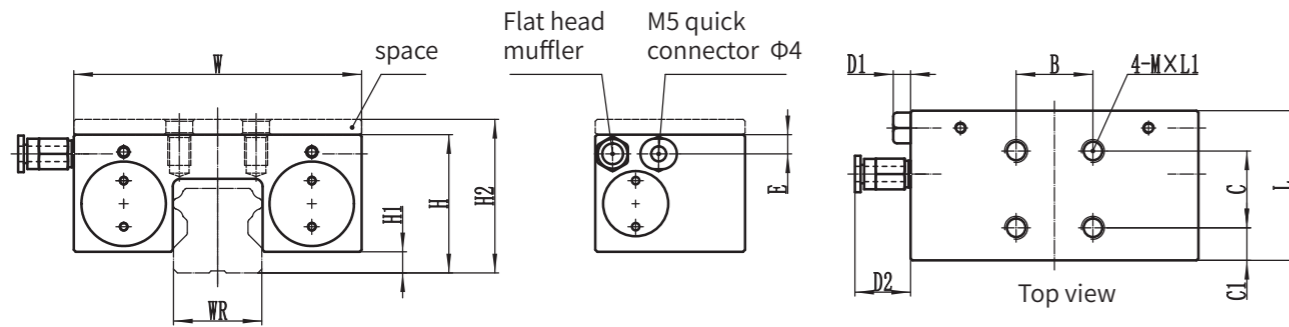

Unit : mm

Model No.	W	W _R	H	H ₁	H ₂	L	B	C	C ₁	M×L ₁	E	D ₁	D ₂	retention (N)	Gas volume (L/cycle)	Weight (kg)
GH20QK	66	20	30	4.5	-	39	20	20	9.5	M5×6	5	4.5	14.5	1000	0.018	0.33
GH25QK	75	23	36	5.5	42	39	20	20	8.5	M5×8	5	4.5	14.5	1200	0.025	0.45
GH30QK	90	28	42	6	45	42	22	22	8.5	M8×10	6	4.5	14.5	1750	0.034	0.69
GH35QK	100	34	48	7.5	55	42	24	24	9	M8×10	6.5	4.5	14.5	2000	0.043	0.86
GH45QK	120	45	60	10	70	49	26	26	11.5	M10×15	13	4.5	14.5	2350	0.049	1.51

1. The opening pressure of the clamp in the table above is 0.55 to 0.8MPa
2. In the table above, H represents the combined height of the clamp and GHW slider, while H2 represents the combined height of the clamp and GHH slider with added cushion blocks

QB Series - Pneumatic Normally Open Clamp

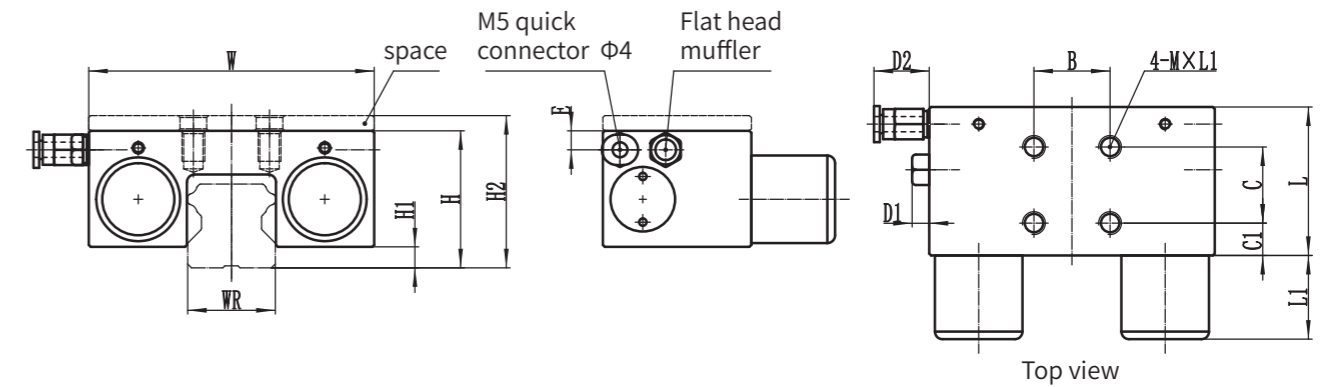

Unit : mm

Model No.	W	W _R	H	H ₁	H ₂	L	L ₁	B	C	C ₁	M×L ₁	E	D ₁	D ₂	retention (N)	Gas volume (L/cycle)	Weight (kg)
GH20QB	66	20	30	4.5	-	39	22	20	20	9.5	M5×6	5	4.5	14.5	600	0.018	
GH25QB	75	23	36	5.5	40	39	22	20	20	8.5	M6×8	5	4.5	14.5	750	0.020	
GH30QB	90	28	42	6	45	42	27.5	22	22	8.5	M8×10	6	4.5	14.5	1050	0.036	
GH35QB	100	34	48	7.5	55	42	27.5	24	24	9	M8×10	6.5	4.5	14.5	1250	0.040	
GH45QB	120	45	60	10	70	49	33	26	26	11.5	M10×15	13	4.5	14.5	1450	0.050	

1. The opening pressure of the clamp in the table above is 0.55 to 0.8MPa
2. In the table above, H represents the combined height of the clamp and GHW slider, while H2 represents the combined height of the clamp and GHH slider with added cushion blocks

>>>

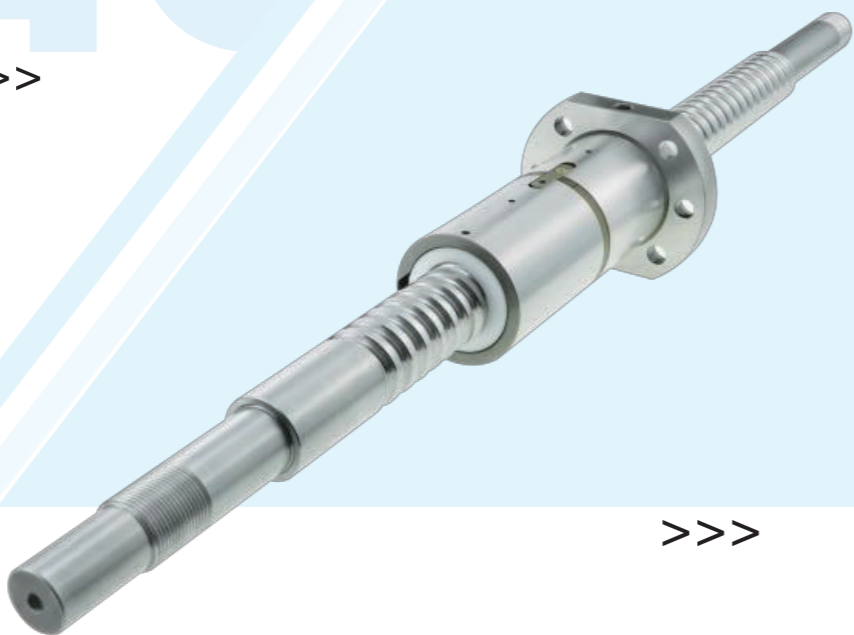

>>>

Preface

Ball screw

Ball screw assembly transmission devices were first invented in 1874 and patented in the United States, but remained underutilized until 1940 when General Motors incorporated them into automotive steering mechanisms, marking the inception of their industrial adoption. The late 1970s to early 1980s witnessed the third industrial revolution spearheaded by microelectronics, which accelerated the proliferation of CNC equipment and consequently advanced industrial specialization in ball screw assembly manufacturing.

Founded in 2007, SHAC originated from the pursuit of ultra-precision manufacturing, specializing in the R&D of high-load-capacity, high-rigidity, and high-accuracy ball screws. By integrating advanced roller screw technologies from leading industrial nations with innovative tribological designs, the brand has successfully transcended the performance boundaries of conventional linear transmission components. Today, SHAC serves as a strategic technology partner in cutting-edge sectors including robotics and aerospace engineering.

1. Fundamental Data

1-1. Ball screw Characteristics

Mechanical Efficiency

- 90% above
- Balance of rigidity

Mechanical efficiency refers to the ratio of output work (useful work) to input work (driving work) expressed as a percentage during steady-state operation of machinery.

Ball screws convert sliding friction in conventional lead screws into rolling friction, and through precision surface grinding, significantly reduce frictional resistance to achieve mechanical efficiencies exceeding 90%. (Figure 1-1 Efficiency)

High efficiency

High efficiency stems from the use of balls as the transmission interface. Rolling friction resistance is significantly lower than sliding friction, reducing parasitic energy losses and enabling superior transmission efficiency. Compared to traditional sliding screw assemblies, drive torque requirements drop to less than one-third—meaning only one-third of the input power achieves equivalent motion output.

Reversible

Due to the point-contact rolling motion between the screw, nut, and steel balls, transmission efficiency exceeds 90%. This enables seamless conversion of rotary motion to linear motion, showcasing intrinsic reversible characteristics.

(Figure 1-1 Reverse Efficiency)

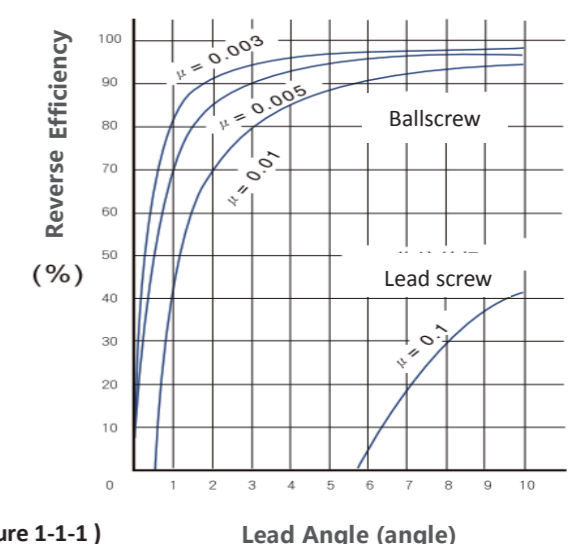
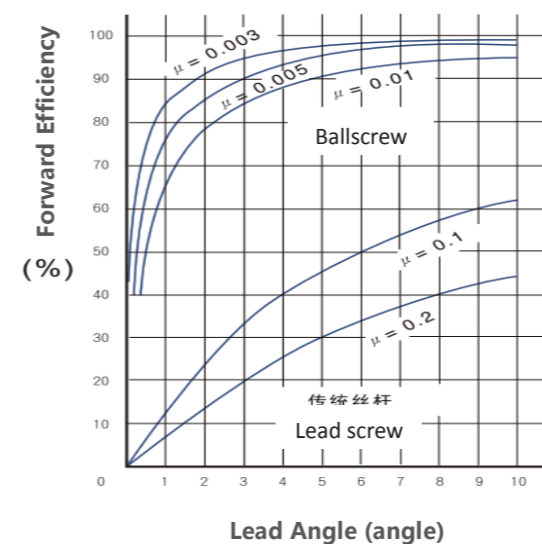

(Figure 1-1-1)

Reversibility

- transition between circular and linear motion
- kinetic energy remains

The reversibility of motion in ball screw drives is fundamentally governed by the symmetry and adjustability of their internal structure. When the driving force changes direction, the ball screw rapidly adapts to the new kinematic state, enabling smooth bidirectional operation. The friction coefficient constitutes another critical factor governing reversibility.

Ball screw drives exhibit motion reversibility, enabling bidirectional operation through drive direction reversal. This reversibility is influenced by screw configuration design, friction coefficient (μ), and magnitude of applied load.



Gothic-arch thread profile

- Two-point contact
- Four-point contact

Ball screws and ball nuts feature Gothic-arch shaped raceways (grooves) in their threads. This profile, characterized by pointed arches and ribbed vault structures, exhibits a dual-circular-arc cross-section in the normal plane of the thread groove.

In ball screw assemblies, the steel balls interface between the screw and nut. With single-nut configurations, the Gothic-arch profiles (featuring dual circular arcs on both screw and nut) typically create four contact surfaces. When subjected to excessive preload via oversized balls, the system transitions to four-point contact mode (Fig.1.1.3). Conversely, in double-nut arrangements, a precision spacer washer induces preload, enabling each nut to independently maintain optimized two-point contact (Fig.1.1.4).



Fig.1.1.2 Gothic-arch thread profile



Fig.1.1.3 Single Nut with four-point contact

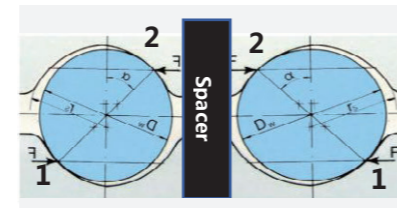
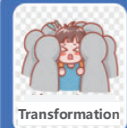

Fig.1.1.4 Double Nut with two-point contact



Zero backlash

- High Rigidity
- Low-Loss

Zero backlash in ball screws refers to an ideal state where no relative displacement occurs between the screw and nut under no-load conditions. Ball screws achieving this state deliver enhanced precision and stability while minimizing transmission errors and vibration.

Ball screws achieve zero backlash functionality through nut spacer structures and optimized ball sizing, where applied preload eliminates axial clearance. By precisely adjusting preload pressure, enhanced rigidity balances operational loads to minimize system losses. SHAC ball screws employ Gothic-arch raceways (Fig. 1.1.2), featuring a 45° contact angle between balls and raceways. Dimensional optimization of steel balls eliminates axial play, enabling supreme motion accuracy.



Durability

- High Hardness
- Low Roughness

Material selection for ball screws is critical to their durability. High-grade alloys provide superior abrasion resistance, corrosion protection, and fatigue life. Proper quenching and tempering treatments further enhance hardness and tensile strength to demanding specifications. (Table 1.1)

Ball screws achieve exceptional durability through high surface hardness (HRC 58-62) and ultra-finished surfaces ($R_a \leq 0.4\mu\text{m}$), effectively resisting frictional wear under operational loads.

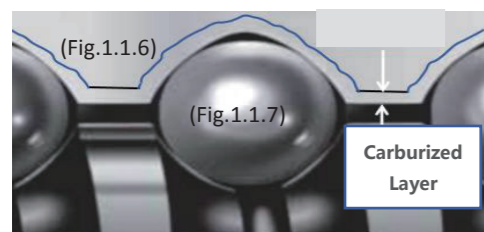

Steel and Heat Treatment			Cr-Mo Steel
Crafts	Item name	Material	Hardness
Induction Hardening	Shaft Fig.1.1.5	50CrMo4 S55C	HRC 58°- 62°
Carburization and Quenching	Nut Fig.1.1.6	20CrMoH (Low Carbon Steel)	HRC 58°- 62°
Fully hardened	Steel Ball Fig.1.1.7	Gcr15 100Cr6 (EN)	HRC 60°UP

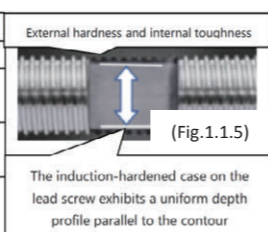

Micron-grade

- Precision Lead
- Micro motion

The positioning accuracy of ball screws encompasses both repeatability and inherent travel precision. Through synergistic optimization of high mechanical efficiency, low frictional resistance, and enhanced rigidity, micron-level displacement accuracy is achieved.

Ball screws achieve lead accuracy within $3.5\mu\text{m}$ per 300mm travel. When integrated with high-load capacity and rigid structural mainframes, they enable micrometer-level displacement control.

1-2 Step-by-Step Selection Guide

1-2-1 Requirements:

1-Equipment Category

2-Precision Level

3-Speed Level

4-Environmental Conditions

Item	Name of Item	Requirements Analysis	Reference
1	Load	What axial load does the ball screw need to drive?	Page 25, Table 1.9.4, 1.9.8
2	Speed	What is the liner speed of the ball nut in meters per minute?	Page 26, Table 1.9.6
3	Acceleration	What is the liner acceleration of the nut in meters per second squared?	Page 27, Table 1.9.9
4	Maximum Displacement Stroke	What is the maximum travel of the equipment?	Page 26, Table 1.9.5
5	Precision of Positioning	What is the positioning accuracy of the equipment?	Page 26, Table 1.9.5
6	Life Requirements	What is the expected service life of the ball screw in hours?	Page 27, Table 1.9.10
7	Vibration Environment	Does the equipment produce vibration during operation?	Page 27, Table 1.9.10 (fs), 1.9.13
8	Shock Environment	Will the equipment experience shock phenomena during operation?	Page 27, Table 1.9.10
9	Air Pollution	Are special gases present in the equipment processing environment?	---
10	Lubricate	Are there any lubrication issues during equipment operation?	Page 40, 1-10-2
11	Other	Are there any lubrication issues during equipment operation?	Page 41, Table 1.10.1

1-2-2 8-Step Selection Procedure

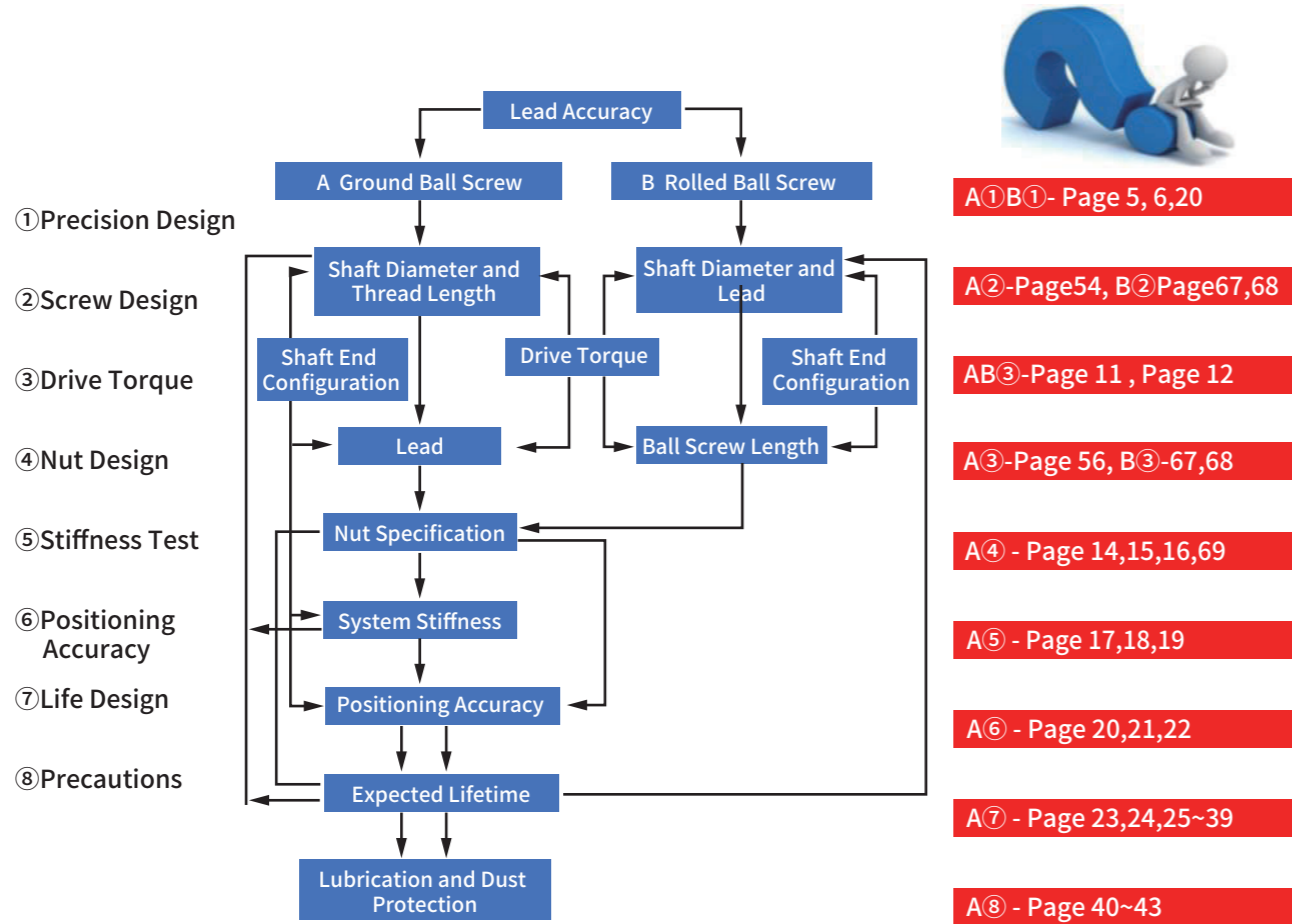

1-3 Accuracy Grade Selection ①

1-3-1 Definition of Positioning Accuracy

SHAC Precision Ball Screws (Grade C0 to C5) have their lead accuracy standardized according to JIS B 1192 specifications, defined by six characteristic parameters: T, e, $e2\pi$, Ve, E, Ve300.

The definitions and tolerance limits for these characteristics are illustrated in Table 1.3.1 and detailed in Tables 1.3.2 and 1.3.3. For General-Grade Ball Screws (C7, C10), the cumulative lead error is only specified by two parameters:

- The tolerance for any 300mm segment within the screw's effective length ($E_{₃₀₀}$)
- The tolerance over the entire effective length (E)

As per Table 1.3.3, the allowable values are: ± 0.05 mm for E300, ± 0.21 mm for E300.

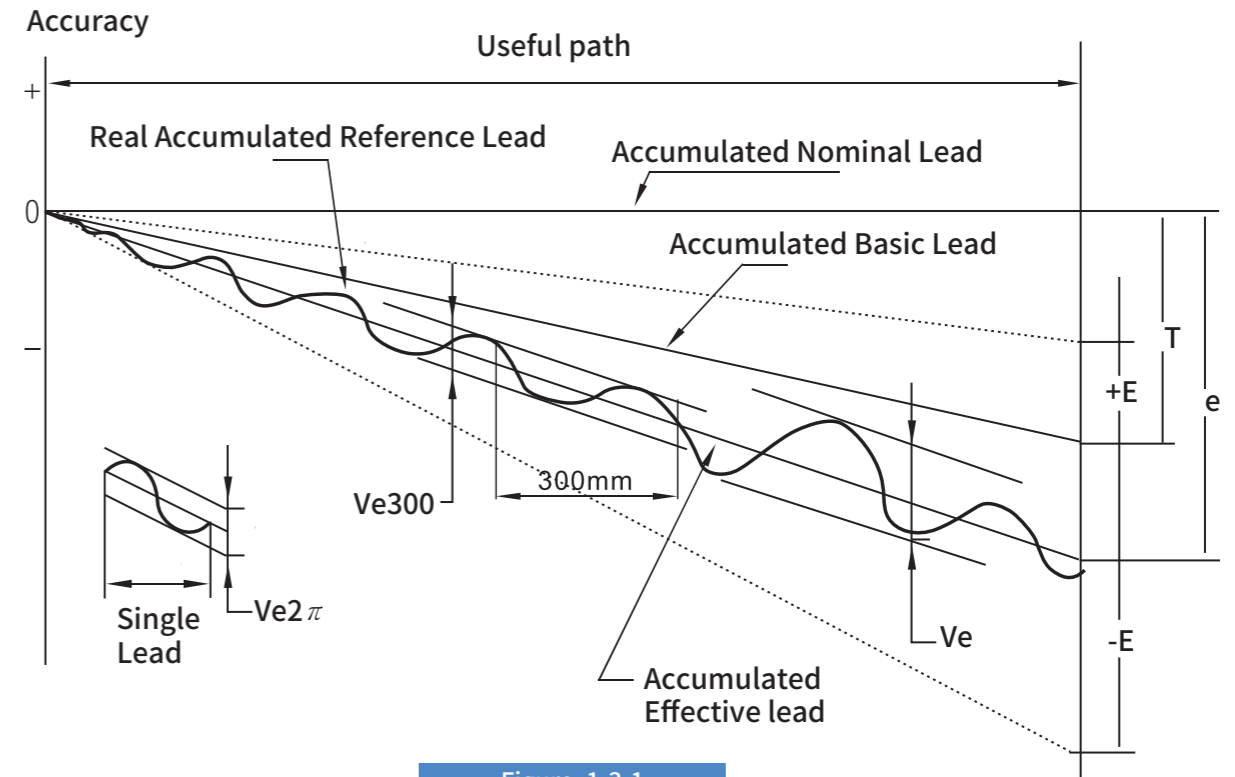

Table 1.3.1 Explanation of Lead Accuracy

T	Target point of accumulated lead. This value is determined by customers' different application requirements.
e	Total reference lead deviation. Maximum deviation for accumulated reference lead line over the full length.
$Ve2\pi$	Single lead variation.
Ve	Real accumulated reference lead measured by laser system.
E	Total relative lead deviation. Maximum deviation of the real accumulated lead from the accumulated reference lead in the corresponding range.
Ve300	Lead deviation over path of 300mm. The above deviation in random 300mm within thread length.

1-3-2 Cumulative Lead Error Comparison Table

For different accuracy classes of ball screws, within a specified effective thread length, corresponding precision requirements apply and can be referenced during selection. The allowable values for the 300mm thread length variation (e_{300}) and periodic fluctuation per revolution ($e_{2\pi}$) are defined according to the JIS B1192 standard.

Table 1.3.2 Precision Grades of High-Precision Ball Screws

Unit: 0.001mm

Accuracy Grade		C0		C1		C2		C3		C5		C7		C10	
e2π		3		4		4		6		8		E		E	
e300		3.5		5		6		8		18					
Item															
Thread Length		E		e		E		e		E		e			
Above	Below														
-	315	4	3.5	6	5	6	6	12	8	23	18	±50/300mm		±210/300mm	
315	400	5	3.5	7	5	7	6	13	10	25	20				
400	500	6	4	8	5	8	7	15	10	27	20				
500	630	6	4	9	6	9	7	16	12	30	23				
630	800	7	5	10	7	10	8	18	13	35	25				
800	1000	8	6	11	8	11	9	21	15	40	27				
1000	1250	9	6	13	9	13	10	24	16	46	30				
1250	1600	11	7	15	10	15	11	29	18	54	35				
1600	2000			18	11	18	13	35	21	65	40				
2000	2500			22	13	22	15	41	24	77	46				
2500	3150			26	15	26	17	50	29	93	54				
3150	4000			30	18	32	21	60	35	115	65				
4000	5000							72	41	140	77				
5000	6300							90	50	170	93				
6300	8000							110	60	210	115				
8000	10000									260	140				
000	12000									320	170				

1-3-3 Accuracy Grade Comparison Table

SHAC ball screw accuracy complies with international standards, though note that its specifications in JIS grade classifications show differences. Refer to Table 1.3.3 for comparative alignment.

Table 1.3.3 Allowable Values for Axial Variation over 300mm Thread Length (e300) and Wobble Error per Revolution (e2π) per JIS B 1192

Accuracy Grade		C0	C1	C2	C3	C5	C7	C10	
ISO, DIN	e300		6		12	23	52	210	
JIS		3.5	5		8	18	50	210	
SHAC		3.5	5	6	8	18	50	210	
	e2π	3	4	4	6	8			
Machining Processes		Ground Screw							
		Peeling \ Rolled Screw							

1-3-4 Ball Screw Mounting Interface Precision

Based on DIN 69051 and JIS B 1192 standard, the precision measurement items are translated as follows:

1. Total Radial Run-out of Screw Shaft Relative to Thread Groove Surface at Outer Diameter AA'
2. Circular Radial Run-out of Screw Support Section Relative to Thread Groove Surface at Outer Diameter AA'
3. Concentricity of Support Section and Component Mounting Surface Relative to Screw Shaft at Outer Diameter AA'
4. Perpendicularity of Screw Support Section End Face Relative to Screw Shaft at Outer Diameter AA'
5. Perpendicularity of Nut Reference Surface/Flange Mounting Face Relative to Screw Shaft at Outer Diameter BB'
6. Run-out of Nut Outer Diameter Relative to Screw Shaft at Outer Diameter BB'
7. Parallelism of Nut Outer Rim (Flat Mounting Face) Relative to Screw Outer Diameter BB'

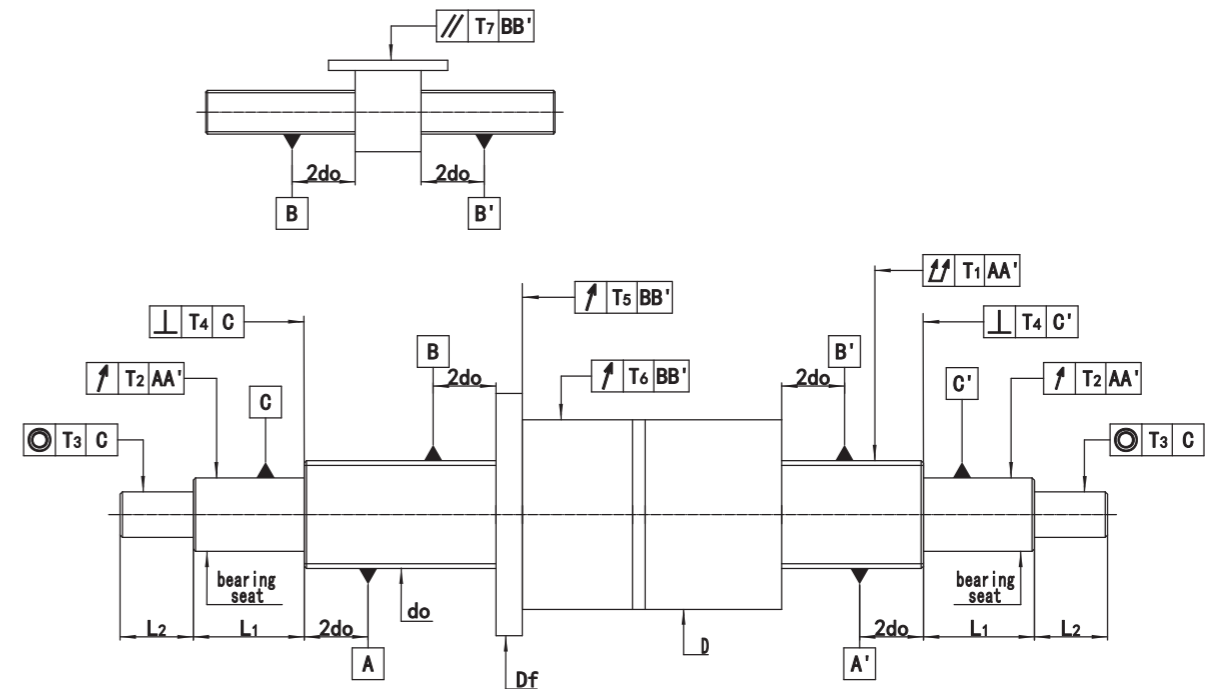

Figure 1.3.4 Grinding-Grade Ball Screw Mounting Interface Precision

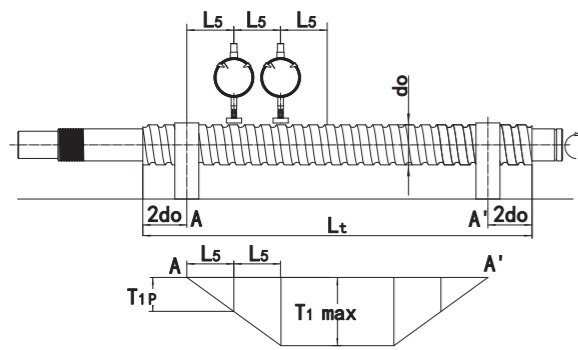

Figure 1.3.5

Table 1.3.4

T1: True running deviation of external diameter relation to AA'

(This measurement is made according to DIN 69051 and JIS B119121)

Nominal diameter do (mm)		Basic length	T1 (μm) Accuracy level						
Above	up to	L5	0	1	2	3	5	7	
6	12	80							
12	25	160							
25	50	315	20	20	20	23	28	40	
50	100	630							
100	200	1250							
Lt/do		T1 MAX (μm) (for Lt ≥ 4L5), Accuracy level							
Above	up to		0	1	2	3	5	7	
	40	40	40	40	40	45	60	80	
40	60	60	60	60	60	70	85	120	
60	80	100	100	100	100	115	140	200	
80	100	160	160	160	160	180	220	320	

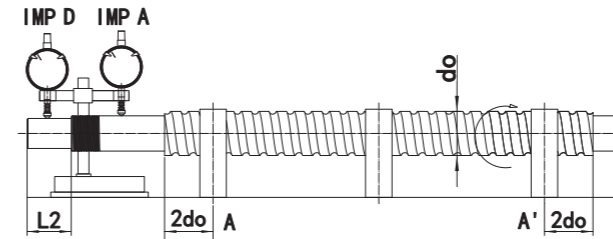

Figure 1.3.7

Table 1.3.6

T3: Coaxial deviation relative to AA'

(This measurement is made according to DIN 69051 and JIS B119121)

Nominal diameter do (mm)		Reference length	T3a (μm) (for L2 ≤ Lr) For tolerance level						
Above	up to	Lr	0	1	2	3	5	7	
6	20	80	4	5	5	6	7	12	
20	50	125	5	6	6	7	9	16	
50	125	200	6	7	8	9	11	20	
125	200	315				10	14	25	

If L2 > Lr, then t3 ≤ T3a L2/Lr

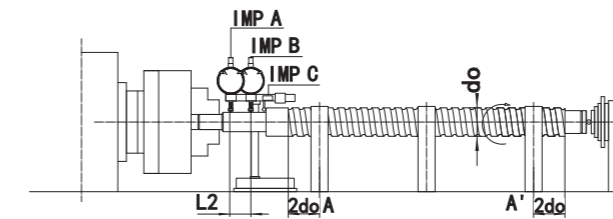

Figure 1.3.8

Table 1.3.7

T4: Run-out deviation of bearing end shoulder relative to AA'

(This measurement is made according to DIN 69051 and JIS B119121)

Nominal diameter do (mm)		T4a (μm) For tolerance level						
Above	up to	0	1	2	3	5	7	
6	63	3	3	3	4	5	6	
63	125	3	4	4	5	6	8	
125	200	-	-	-	6	8	10	

Table 1.3.5

T2: Run out deviation of bearing relative to AA'

(This measurement is made according to DIN 69051 and JIS B119121)

Nominal diameter do (mm)		Reference length	T2a (μm) (for L1 ≤ Lr) For tolerance level						
Above	up to	Lr	0	1	2	3	5	7	
6	20	80	6	8	10	11	16	40	
20	50	125	8	10	12	14	20	50	
50	125	200	10	12	16	18	26	63	
125	200	315				20	32	82	

If L1 > Lr, then t2b ≤ T2a L1/Lr

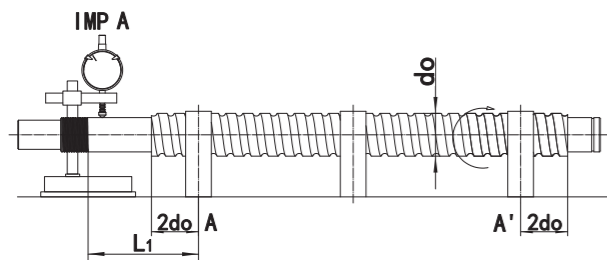

Figure 1.3.6

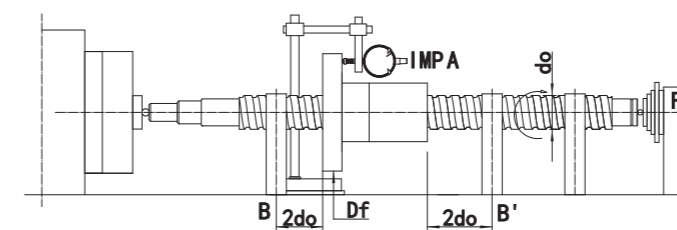

Figure 1.3.9

Table 1.3.8

T5: Face running deviation of locating face (only for nut) relative to BB'

(This measurement is made according to DIN 69051 and JIS B119121)

Nut Flange diameter do(mm)		T5a (μm) For tolerance level						
Above	up to	0	1	2	3	5	7	
	20	5	6	7	8	10	14	
20	32	5	6	7	8	10	14	
32	50	6	7	8	8	11	18	
50	80	7	8	9	10	13	18	
80	125	7	9	10	11	15	20	
125	160	8	10	11	13	17	20	
160	200	-	11	12	14	18	25	
200	250	-	12	14	15	20	30	

1-4 Ball Screw Journal/Shaft End Configuration Selection ②

1-4-1 Mounting Configuration

The fixing method constitutes an essential consideration during ball screw selection, directly impacting precision, service life, and system performance. This influence manifests in three core design parameters: rigidity, critical speed, and buckling load. The primary fixation configurations are outlined below and should be selected according to operational requirements.

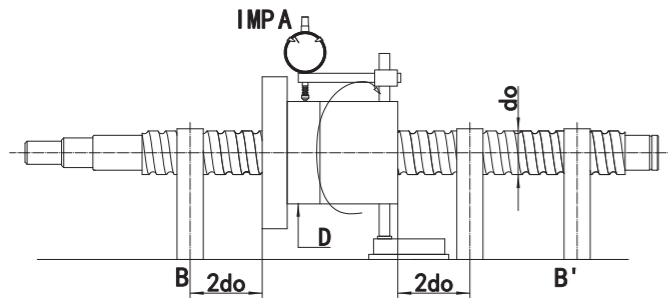

Figure 1.3.10

Table 1.3.9

T6: Run-out deviation of external diameter (only for nut) relative to BB'
(This measurement is made according to DIN 69051 and JIS B119121)

Nut Flange diameter do (mm)		T6a (μm) For tolerance level					
Above	up to	0	1	2	3	5	7
	20	5	6	7	9	12	20
20	32	6	7	8	10	12	20
32	50	7	8	10	12	15	25
50	80	8	10	12	15	19	30
80	125	9	12	16	20	22	40
125	160	10	13	17	22	28	40
160	200		16	20	22	28	40
200	250		17	20	22	28	40

Table 1.3.10

T7: Deviation of parallelism (only for nut) relative to BB'
(This measurement is made according to DIN 69051 and JIS B119121)

Nutting basic Length (mm) Lr		T7a (μm) /100mm For tolerance level					
Above	up to	0	1	2	3	5	7
	50	5	6	7	8	10	17
50	100	7	8	9	10	13	17
100	200		10	11	13	17	30

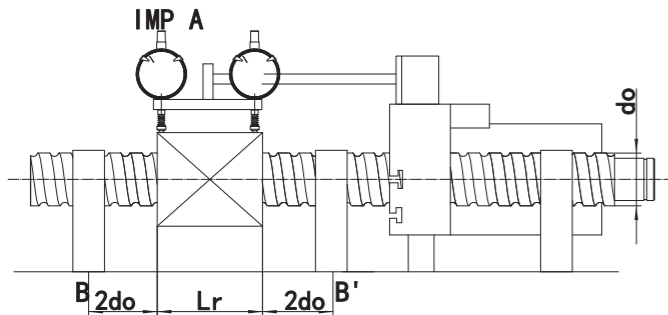

Figure 1.3.11

Note:

The geometric tolerance standard for SHAC ball screw drawing shall be executed in accordance with the specifications of DIN 69051 and JIS B11921 unless the customer has special requirements.

Figure 1.4 Screw Shaft & Nut Assembly Mounting Configuration

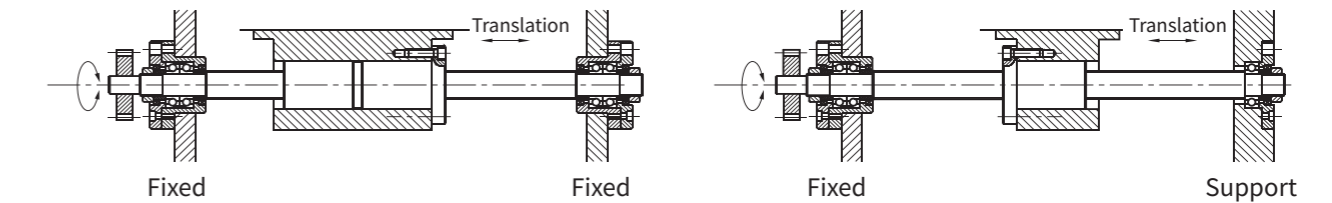

Fig.1.4.1

Fig.1.4.2

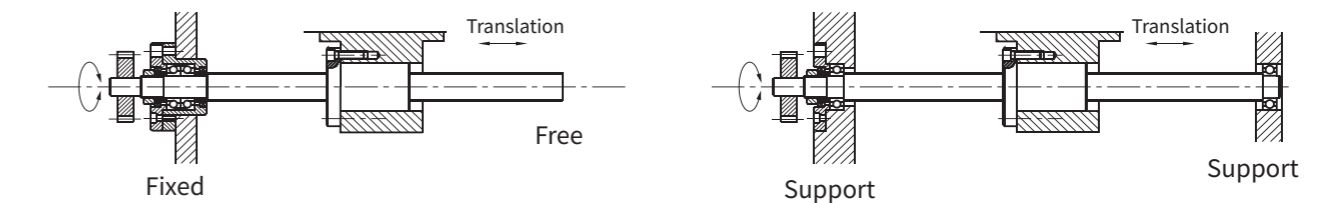

Fig.1.4.3

Fig.1.4.4

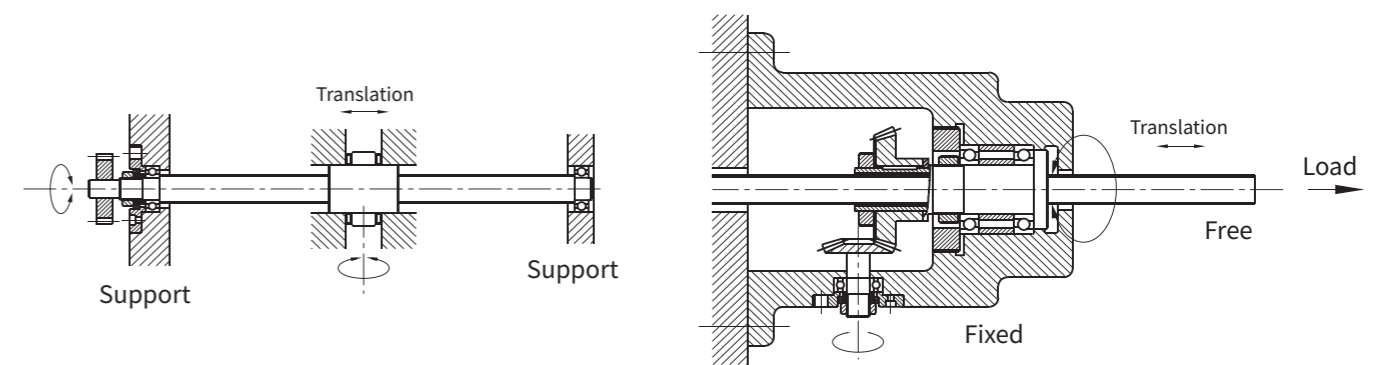

Fig.1.4.5

Fig.1.4.6

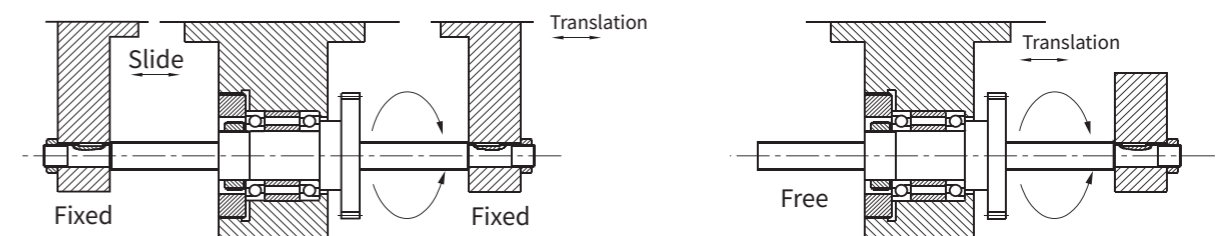

Fig.1.4.7

Fig.1.4.8

(Axial Constraint Systems for Ball Screw in Machine)

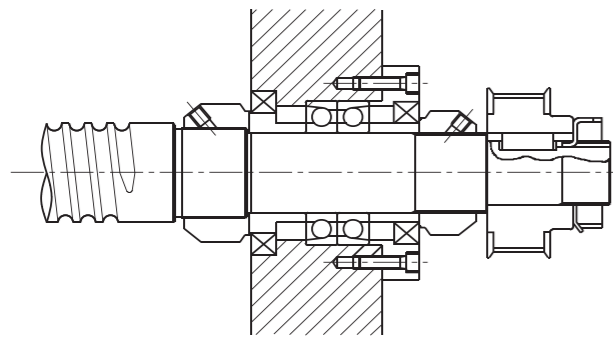

Fig.1.4.9

Fig.1.4.9 Light-Duty Timing Belt Drive with Standard Duplex Bearing Configuration

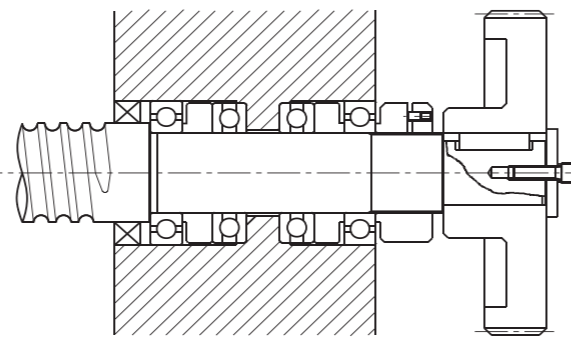

Fig.1.4.10

Fig.1.4.10 Heavy-Duty Gear Transmission with Enhanced Radial Capacity & Sustained Load Bearing Configuration

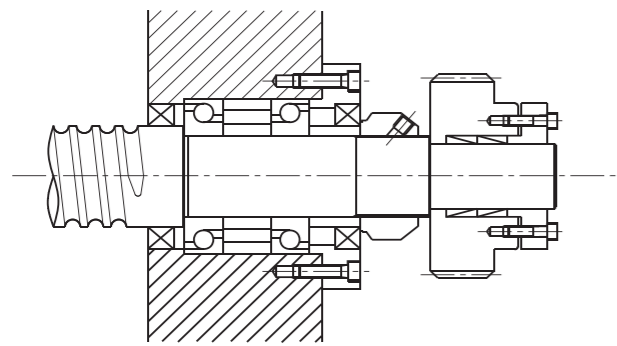

Fig.1.4.11

Fig.1.4.11 Enhanced Radial Load Capacity in Gear-Driven Ball Screws via Extended Bearing Span with Precision Spacer Rings

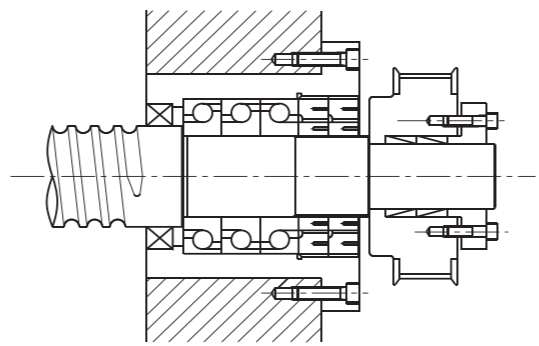

Fig.1.4.12

Fig.1.4.12 Short-Journal Pulley Drive with Enhanced Load Capacity via Triplex Bearing Configuration

Adjustable Pre-Tension Mounting Configuration for Ball Screw

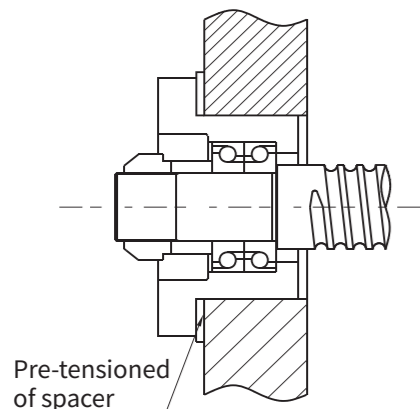

Fig.1.4.13

Fig. 1.4.13 Rapid-Adjust Shim Kits for Pre-Tension Preload Control

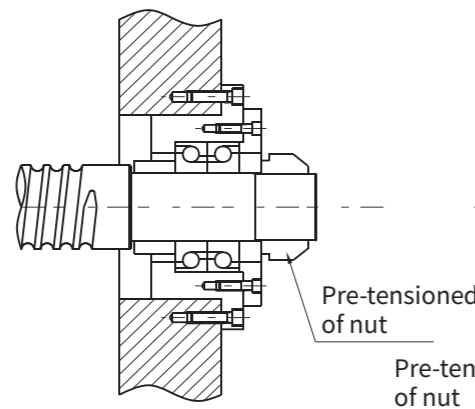

Fig.1.4.14

Fig. 1.4.14 Torque-Controlled Pre-Tensioning with Standard Locknut Assembly

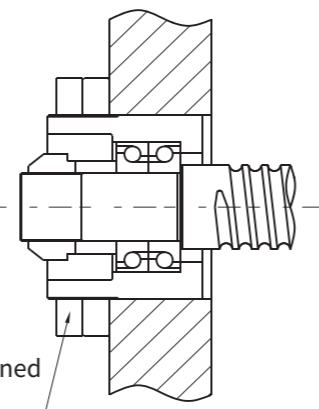

Fig.1.4.15

Fig. 1.4.15 High-Capacity Lock-nut Assembly with Thermal Growth Accommodation for

1-4-2 Screw Shaft End Dimensions

▲Screw Shaft End Configuration

Standard end configurations, as shown in Figure 1.4.16, while bearing model selection based on recommended size ranges is provided in Table 1.4.2 .

Table 1.4.2 Shaft End Dimensions

Model	d1	d5	d6	d7	d8	E	L3	L4	L5	L6	L7	L8	L9	L10	L11	L12	L13	bxt1	Recommended Bearings	
																			I,II,III DIN625	III,IV,V DIN625 628 720
10	10	8	7.6	M8x0.75	6	6	16	7	29	26	0.9	39	50	56	18	10	12	3.0x1.8	608	738B
12	12	8	7.6	M8x0.75	6	6	16	7	29	26	0.9	39	50	56	18	10	12	3.0x1.8	608	738B
14	14	10	9.6	M10x0.75	8	8	20	9	37	34	1.15	45	54	62	20	10	14	3.0x1.8	6200	7200BTVP
16	16	12	11.5	M12x1	10	8	21	10	41	38	1.15	46	56	66	20	10	14	4.0x2.5	6201	7301BTVP
20	20	15	14.3	M15x1	12		22	11	47	44	1.15	55	70	84	25	13	16	5.0x3.0	6202	7302BTVP
25	25	17	16.2	M17x1	15		23	12	49	46	1.15	56	72	86	25	13	16	5.0x3.0	6203	7203BTVP
28	28	20	19.0	M20x1	16		26	14	58	54	1.35	68	82	100	28	20	18	6.0x3.5	6204	7602020BTVP
32	32	25	23.9	M25x1.5	20		27	15	64	60	1.35	79	94	116	36	22	26	7.0x4.0	6205	7602025BTVP
36	36	25	23.9	M25x1.5	20		27	15	64	60	1.35	79	94	116	36	22	26	7.0x4.0	6205	7602025BTVP
40	40	30	28.6	M30x1.5	25		28	16	68	64	1.65	86	102	126	42	22	32	8.0x4.0	6206	7602030BTVP
45	45	35	33.3	M35x1.5	30		29	17	80	76	1.65	97	114	148	50	24	40	10.0x5.0	6207	7602035BTVP
50	50	40	38.0	M40x1.5	35		36	23	93	88	1.95	113	126	160	60	24	45	12.0x5.0	6308	7602040BTVP
55	55	45	42.5	M45x1.5	40		38	25	93	88	1.95	125	138	168	70	24	50	14.0x5.5	6309	7602045BTVP
63	63	50	47.0	M50x1.5	45		33	27	102	97	2.2	140	153	188	80	27	60	14.0x5.5	6310	7602050BTVP
70	70	55	52.0	M55x2.0	50	10	44	29	118	113	2.2	154	167	212	90	27	70	16.0x6.0	6311	7602055BTVP
80	80	65	62.0	M65x2.0	60	10	49	33	132	126	2.7	171	184	234	100	30	80	18.0x7.0	6313	7602065BTVP
100	100	75	72.0	M75x2.0	70	10	53	37	140	134	2.7	195	208	258	120	30	90	20.0x7.5	6315	7602075BTVP

Figure 1.4.16

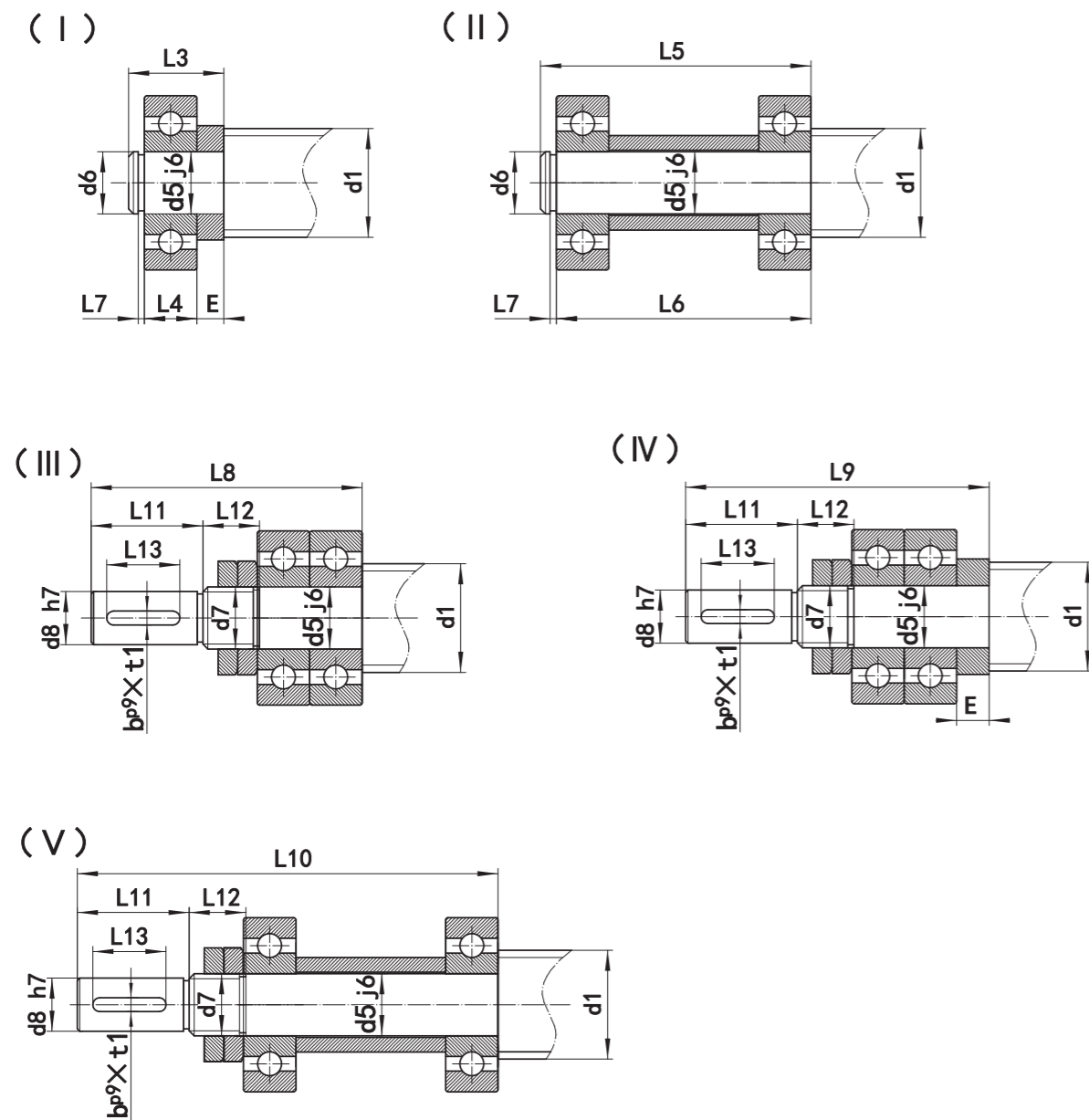

Note: 1-Over years, the adoption of couplings has largely superseded the use of keyway, reducing the likelihood of radial shear stress occurrence.
 2-The use of spacer rings compensates for inadequate bearing abutment area caused by thread relief on the screw shaft.

1-5 Ball Screw Drive Torque ③

1-5-1 Preload Torque

The torque required to continuously rotate a ball screw without external load is defined as the preload torque.

Figure 1.5.1 illustrates the terminology for preload torque generated by rotating a preload ball screw. Table 4.B.4 specifies the allowable range of preload torque variation under JIS standards (JIS B 1192-2019) in page 41.

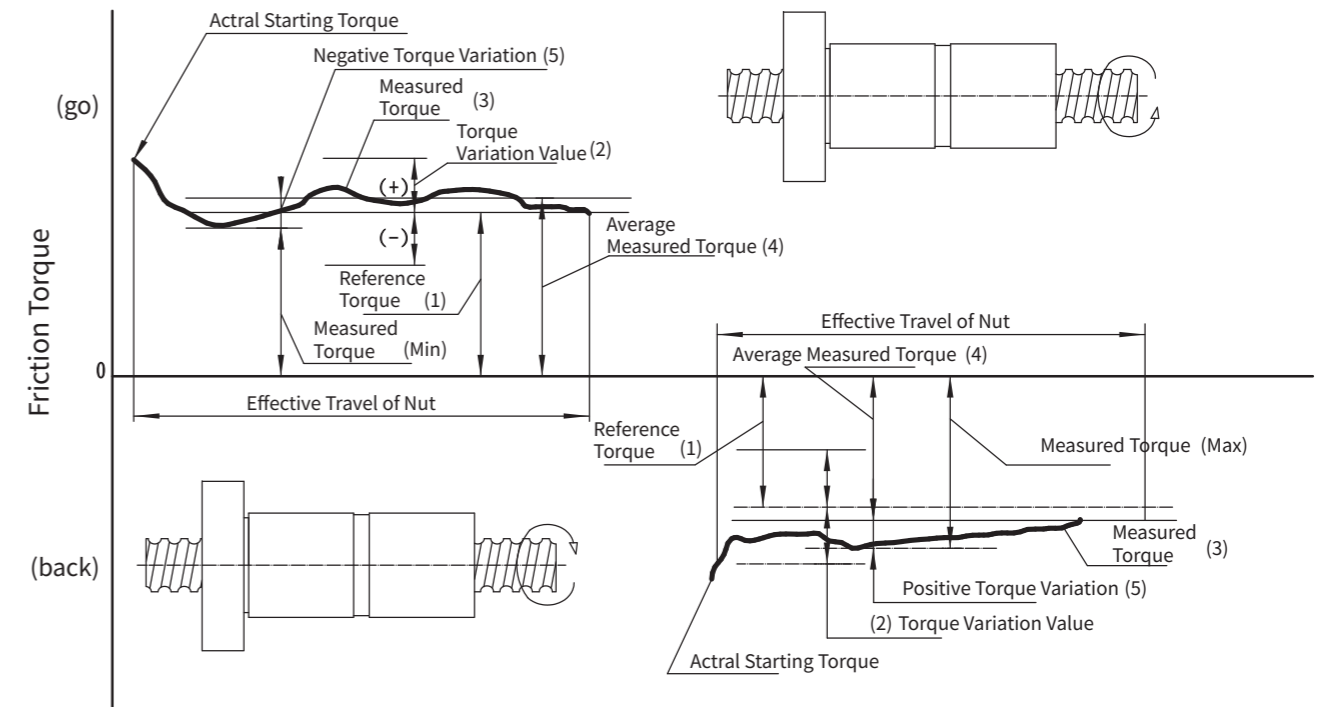

Figure 1.5.1 Preload Torque Illustration

Table 1.5.1 Definition of Preload Torque

Name	Meaning
Preload	To eliminate backlash and increase rigidity in ball screw assemblies, internal preload is generated either by: (1)Installing oversized-diameter balls, (2)Inserting preload spacers between dual nuts, Thereby inducing controlled elastic deformation within the screw/nut/ball interface.
Preload Torque	The torque required to continuously rotate the screw or nut without external load is defined as P preload Torque.
Reference Torque(1)	Predetermined Target Preload Torque Value
Torque Variation Value(2)	Predetermined Reference Torque Variation Allowance
Torque Variation Ratio	Reference Torque to Variation Ration
Measured Torque(3)	Actual Measured Preload Torque Value
Average Measured Torque(4)	Arithmetic Mean of Actual Torque Values Over Effective Thread Length
Actual Torque Variation Value(5)	Within the effective thread length, the maximum variation value of preload torque exhibits both positive and negative deviations relative to the average actual torque.
Actual Torque Variation Ration	Ratiu of Average Actual Torque to Actual Torque Variation

1-5-2 Driving Torque

Drive torque applied to the transmission shaft TS

$$TS = TP + TD + TF \quad (\text{Uniform velocity})$$

$$TS = TG + TP + TD + TF \quad (\text{Acceleration})$$

TG: Acceleration torque (1)
 TP: Load torque (2)
 TD: Preload torque (3)
 TF: Frictional torque (4)

(1)Acceleration torque TG

$$T_G = J\alpha \quad (\text{kgf} \times \text{cm})$$

$$\alpha = \frac{2\pi n}{60\Delta t} \quad (\text{rad/s}^2)$$

J: Inertia torque (kgf-cm-s²)
 α: Angular acceleration (rad/s²)
 n: Rotational Speed (rpm)
 Δt: Acceleration Time (s)

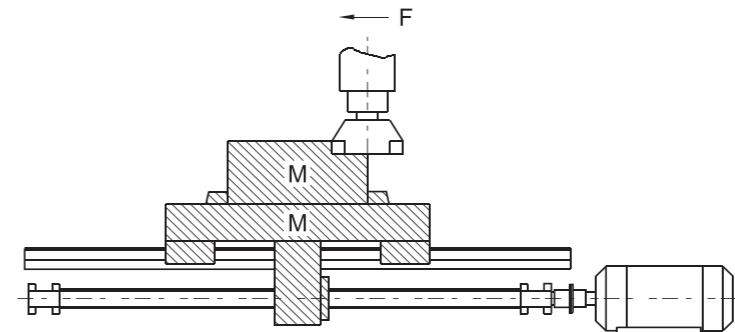

Fig. 1.5.1 Load inertia torque

(2)Load torque TP

$$T_P = \frac{P \times \ell}{2\pi\eta_1} \quad (\text{kgf} \times \text{cm})$$

$$P = F + \mu Mg$$

P: Axial Load (kgf)
 ℓ: Lead (2)
 η₁: Forward Efficiency
 ↳ Efficiency of converting rotational motion to linear motion
 F: Cutting Force (kgf)
 μ: Coefficient of Friction
 M: Load mass (kg)
 g: Gravitational acceleration

$$T_P = \frac{P \times \ell \times \eta_2}{2\pi} \quad (\text{kgf} \times \text{cm})$$

η₂: Backdrive Efficiency
 ↳ Efficiency of converting rotational motion to linear motion

(3)Preload torque

$$T_D = \frac{K \times P_{PL} \times \ell}{\sqrt{\tan\alpha} \times 2\pi} \quad (\text{kgf} \times \text{cm})$$

K: Internal coefficient (Default:0.05)
 P_{PL}: Preload (kgf)
 ℓ: Lead (2)
 α: Lead Angle

(4) Frictional torque TF

$$TF = TB + T0 + TJ$$

TB : Frictional torque at the support end
 T0 : Frictional torque at the free end
 TJ : Frictional torque in electric motors

Note : Frictional torque at the support end is subject to variation depending on operational conditions.

Please reference Table 1.5.1 Load inertia torque

$$J = JBS + JCU + JW + JM$$

JBS: Ball screw Inertia
 JCU: Coupling Inertia
 JW: Linear motion part Inertia
 JM: Motor rotor section Inertia

Table 1.5.2 Load Inertia Torque Conversion

Motor Shaft Inertia Torque Conversion	Formula J
Cylindrical Load	$\frac{\pi \rho L D^4}{32}$
Object in Linear Motion	$\frac{M}{4} \left(\frac{V \ell}{\pi \times N_M} \right)^2 = \frac{M}{4} \left(\frac{P}{\pi} \right)^2$
Unit	kg × m ²
Inertia Torque During Deceleration	$J_M = \left(\frac{J \ell}{N_M} \right)^2 \times J \ell$

ρ : thickness
 L: Cylinder Length(m)
 D: Cylinder Diameter(m)
 M: Load Mass(kg)
 $V \ell$: Linear Velocity (m/min)
 NM: Motor Speed (rpm)
 P: Load Displacement per Motor Revolution
 $N \ell$: Directional Feed Rate from Rotationa Speed
 $J \ell$: Load Di rectional l nertia Torque
 JM: Motor DirectionalInertia Torque

Table 1.5.1 Load Inertia Torque Conversion

Re-circulation Method	Specification		Characteristic
	Single Nut	Double Nut	
Internal circulation	SFK		<ul style="list-style-type: none"> ● Compact outer diameter ● Recommended for small-lead applications
	SFNU	DFNU	
	SFU	DFU/OFNU	
	SFI	DFI	
External circulation	SFNI	DFNI/OFNL	<ul style="list-style-type: none"> ● Economy Series ● Engineered for large-lead, high-load applications
	SFB	DFB	
End-plug circulation	SFBH	/	<ul style="list-style-type: none"> ● Silent-High Speed Series ● Suitable for high-speed feed applications
	SFS	DFS	
	SFY	/	
	SFE	DFE	
	SFA	/	

1-6 Ball Screw Nut Selection ④

1-6-1 Nut Selection

<p>Nut Series Selecting the appropriate nut type based on comprehensive consideration of precision, dimensions, flange configuration, and lead time</p> <p>Recirculation Method Ball recirculation methods can be categorized as internal recirculation, external recirculation, End-plug recirculation, etc., each with distinct advantages and disadvantages that must be selected according to application requirements.</p>	<p>Steel Ball Circuit Rank Variations in the circuit tie r count significantly impact the nut's load capacity, noise generation, and service life.</p> <p>Flange Configuration Flange configuration shall be determined based on the actual spatial constraints of the installation Interface, including round, single-cropped, Double-cropped, and quad-cropped types.</p> <p>Oil Filler Port Applying appropriate lubricant (oil/grease) to the nut significantly enhances ball screw smoothness, ensures long-term precision retention, and extends service life.</p>
---	---

1-6-2 Nut Configuration

K. NU. NI Type Nut

Internal circulation Nut: Ball bearings travel along the deflector raceway, diagonally climb over the screw thread crest, and return to the cycle origin. One revolution completes a single circuit, while a single nut typically integrates 3-6 discrete circuits as illustrated in Fig 1.6.1. This design is optimized for compact models with small leads

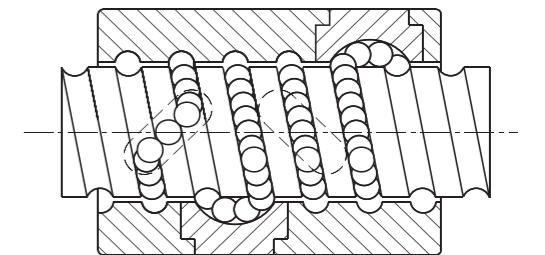
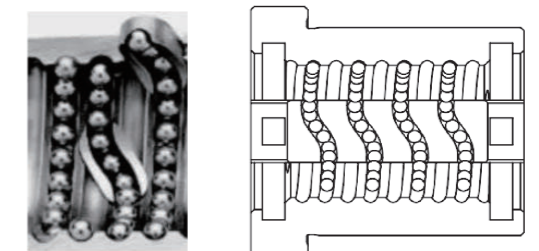

Fig. 1.6.1 Internal Circulation

Table 1.6.2

Specifica tion	Characteristic	Advantage	Deficiency
SFU DFI SFK	<ul style="list-style-type: none"> ● Compact outer diameter ● Optimized for small leads ● DN value 70,000 	<ul style="list-style-type: none"> ● Optimized for slow-speed reciprocating motion ● Metal deflector resists impact loads ● Withstands 120° C operating temperatures 	<ul style="list-style-type: none"> ● High-speed traverse ● Complex deflector machining



Y.E-Type Nuts:

This circulation design shares similarities with S-type nuts. While retaining the advantages of S-type circulation, it incorporates thin yet resilient end seals that enhance scraping effectiveness. The reinforced return path structure significantly boosts rigidity and high-speed performance.

As shown in Fig. 1.6.2 (right)

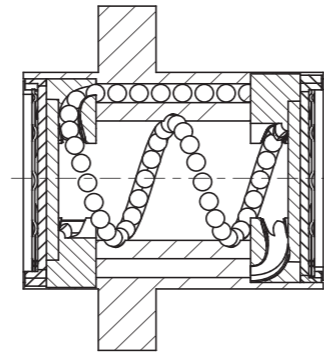

Fig. 1.6.2



Table 1.6.3

Specification	Characteristic	Advantage	Deficiency
SFY SFE	Dual- Start Nuts for High- Speed Traverse & Extreme DN Values	<ul style="list-style-type: none"> • High-Speed, • High-Load Performance • DN value 120,000 	<ul style="list-style-type: none"> • Premium Lubrication • Precision-Controlled Preload

A. S- Type Nut

A and S-type nut operates through precision steel balls rolling along the helical grooves between the screw shaft and nut body. These balls are continuously recirculated via dedicated return channels integrated at both ends of the circulator. (Fig. 1.6.3)

The circulative system operates identically to E-Type nuts, featuring a helical ball trajectory aligned with the screw thread direction. This design, combined with acoustic-damped end caps and integrated dust seals, reduces operational noise

Furthermore, the S-type nut achieves a reduction in installation envelope compared to conventional designs. This compact architecture, combined with precision-circulation dynamics, makes it ideal suited for high-speed, light-load applications.

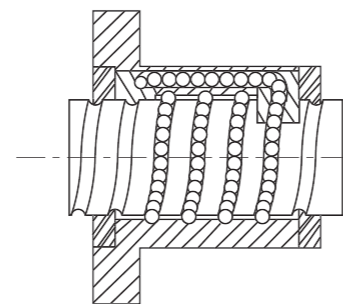

Fig. 1.6.3

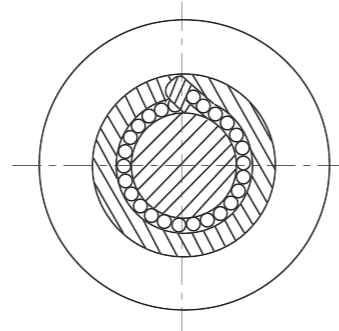

Table 1.6.3

Specification	Characteristic	Advantage	Deficiency
SFS DFS	<ul style="list-style-type: none"> • Silent High-Speed Series • High- Speed Translation Compatible 	<ul style="list-style-type: none"> • Reduced Operating Noise • Compared to Standard Models 	<ul style="list-style-type: none"> • Outer Diameter to Lead Ratio = 1:1 • Requires Enhanced Lubrication Efficiency

Note:

Regarding DN values, dust prevention devices, surface treatment, etc, please refer to Table 5.1.1 on Page 52.

Please refer to pages 79, 80, 81, and 82 for the outer diameter and nut size tables of each screw.

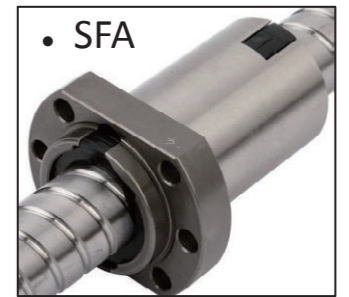

1-7 Ball Screw Rigidity Design ⑤

The rigidity of ball screw directly governs their positioning accuracy. This consequently affects the overall system's positioning precision, leading to effect including machining position loss during cutting operations. Therefore, integrated rigidity design of all constituent components is imperative.

1-7-1 Rigidity (K)

Axial Elastic Deformation and Rigidity Calculation Formulas for Lead Screws

$$K = \frac{P}{e} \text{ (kgf/mm)}$$

P: Axial Load on Ball Screws (kgf)

E: Axial Elastic Deformation of Ball Screws (mm)

$$\frac{1}{K} = \frac{1}{K_s} \times \frac{1}{K_N} \times \frac{1}{K_B} \times \frac{1}{K_H} \text{ (mm/kgf)}$$

K_s : Axial Rigidity of Ball Screws (1)

K_B : Axial Rigidity of Ball Screws (3)

K_N : Axial Rigidity of Ball Screws (2)

K_H : Axial Rigidity of Ball Screws (4)

Axial Rigidity K_s and Deformation δ of Ball Screws

$$K_s = \frac{P}{\delta_s} \text{ (kgf/mm)}$$

P: Axial Load on Ball Screws (kgf)

Fixed-Fixed Mounting Configuration

$$\delta_{SF} = \frac{PL}{4AE} \text{ (mm)}$$

$$\delta_{SS} = \frac{PL_0}{AE} \text{ (mm)}$$

$$\delta_{SS} = 4 \delta_{SF}$$

δ_{SF} : Axial Deformation in Fixed-Fixed Mounting Configuration

δ_{SS} : Axial Deformation in Alternative Mounting Configurations

A: Root Cross-Sectional Area of Screw Shaft (mm²)

E: Young's Modulus (Longitudinal Elastic Modulus) = 2.1×10^4 kgf/mm²

L: Mounting Span (mm)

L₀: Load Application Point Span (mm)

1-7-2 Nut Axial Stiffness KN and Nut Deformation δN

$$K_N = \frac{P}{\delta_S} \text{ (kgf/mm)}$$

Single Nut

$$\delta_{NS} = \frac{K}{\sin \beta} \left(\frac{Q^2}{d} \right)^{\frac{1}{3}} \times \frac{1}{\zeta} \text{ (mm)}$$

$$Q = \frac{P}{n \times \sin \beta} \text{ (kgf)}$$

$$n = \frac{D0\pi m}{d} \text{ (Pes)}$$

Q: Load on a Single Steel Ball (kgf)

n: Quantity of Steel Ball (kgf)

K: Constant determined by material, shape, dimensions, and other factors

$$k \approx 5.7 \times 10^{-1}$$

β: Contact Angle (45°)

P: Axial Load (kgf)

d: Steel Ball Diameter (mm)

ζ: precision and internal stress coefficients

m: Effective Number

D: Pitch Diameter (mm)

ℓ: Lead

α: Lead Angel

$$D0 = \frac{\ell}{\tan \alpha \times \pi}$$

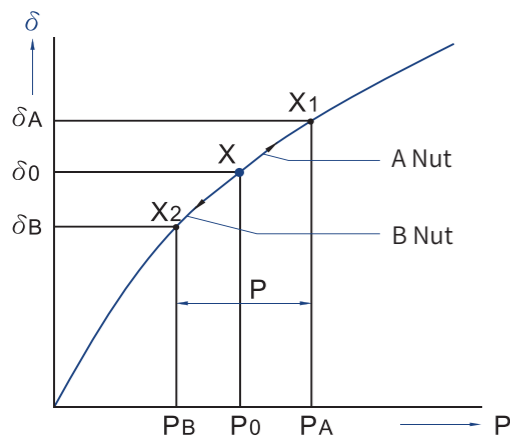

Double Nut

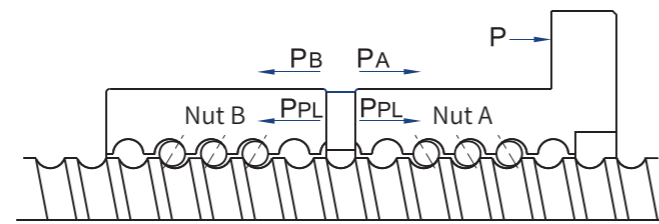

Figure 1.7.1 Double-Nut

We recommend setting the preload force PPL to ≤1/3 of the maximum axial load.

Excessive preload accelerates temperature rise and reduces service life. When PPL=1/3P, it eliminates preload force on the counter nut.

Deformation Characteristics

$$K_N = \frac{P}{\delta_{NW}} = \frac{3P_{PL}}{\delta_{NS/2}} = \frac{6P_{PL}}{\delta_{NS}} \text{ (kgf/mm)}$$

δNS: Deformation of a Single Nut (mm)

δNW: Deformation of Duplex Nut Assembly (mm)

When preload PPL is applied to double nuts, both the primary nut and counter nut undergo identical elastic deformation XX, as illustrated in Figure 1.7.2

P: If an axial load force P is added, the deformation of the main nut will increase to X1, and that of the secondary nut will decrease to X2.

$$\delta_0 = aP_{PL}^{\frac{2}{3}}$$

$$\delta_A = \delta_B = aP_{PL}^{\frac{2}{3}}$$

$$\delta_A - \delta_0 = \delta_0 - \delta_B$$

$$P_A - P_B = P$$

$$\delta_B = 0$$

$$aP_A^{\frac{2}{3}} - aP_{PL}^{\frac{2}{3}} = aP_{PL}^{\frac{2}{3}}$$

$$P_A^{\frac{2}{3}} = 2P_{PL}^{\frac{2}{3}}$$

$$P_A = \sqrt[3]{8P_{PL}^2} \approx 3P_{PL}$$

$$\delta_A - \delta_0 = \delta_0$$

$$\delta_0 = \frac{\delta_A}{2}$$

Set the preload PPL to ≤1/3 of the maximum axial load, as PPL is approximately 1/3 of the axial load P. This eliminates residual preload on the counter nut. When applying a preload equivalent to 1/4 of the basic dynamic load rating (Ca), the elastic deformation between the raceway and balls is half that achieved when preload at 1/3 of the maximum axial load.

Based on the mechanical properties illustrated in Figure 1.7.3, it can be determined that when the axial load reaches three times the preload magnitude, a single nut assembly exhibits half the displacement while doubling its axial rigidity.

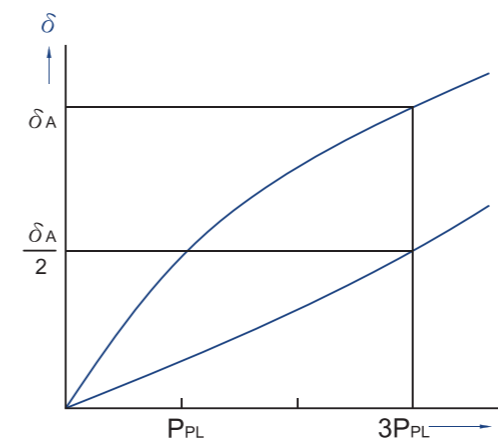

Fig 1.7.3

(3): Support Shaft Axial Rigidity Ka and Displacement δB

$$K_B = \frac{P}{\delta_B} \text{ (kgf/mm)}$$

The angular contact ball bearing assembly, particularly as support bearings for ball screws in precision machinery applications, has its rigidity expressed by the following formula:

$$\delta_B = \frac{2}{\sin \beta} \left(\frac{Q^2}{d} \right)^{\frac{1}{3}}$$

$$Q = \frac{P}{n \times \sin \beta} \text{ (kgf)}$$

Q: one pc Ball Load (kgf)

n: Quantity of Ball

β: Contact Angle (45°)

P: Axial Load (kgf)

d: Ball Diameter (mm)

ℓa: Ball Diameter (mm)

For the axial rigidity KH and displacement δH of the nut and bearing installation part, ensure high rigidity at the installation site during the initial stages of machine development.

$$K_H = \frac{P}{\delta_H} \text{ (kgf/mm)}$$

1-8 Positioning Accuracy of Ball Screw ⑥

1-8-1 Selection of Lead Accuracy for Ball Screw

The primary factors affecting the feed accuracy of ball screw systems include: lead accuracy, preload, and axial rigidity of the feed system. Other factors such as thermal deformation induced by temperature rise effects and insufficient mounting precision must also be considered.

☆ Selection of Lead Accuracy for Different Equipment Types

Select appropriate lead accuracy based on positioning accuracy requirements for different applications; Table 1.8.1 provides recommended values for various equipment types.

Table 1.8.1 Selection of Lead Accuracy for Different Applications

	Application		Accuracy grade						
			C0	C1	C2	C3	C5	C7	C10
CNC Machinery Tools	Lathes	X	○	○	○	○	○	○	
		Z				○	○	○	
	Milling machines	XY		○	○	○	○	○	
		Boring machines	Z			○	○	○	
	Machine Center	XY		○	○	○	○		
		Z			○	○	○		
	Jig borer	Y	○	○					
		Z	○	○					
	Drilling machine	XY				○	○	○	
		Z					○	○	
	Grinder	X	○	○	○	○	○	○	
		Z		○	○	○	○	○	
	EDM	XY		○	○	○	○	○	
(Z)				○	○	○	○		
Wire cut EDM	XY		○	○	○	○	○		
Punching Press	UV		○	○	○	○	○		
Laser Cutting Machine	XY				○	○			
	Z				○	○			
Wood working Machine					○	○	○	○	
Single Purpose Machine				○	○	○	○	○	
Semiconductor equipment	Exposure Equipment		○	○					
	Chemical Treatment Unit					○	○	○	
	Wire Bonder			○	○	○			
	Flying Probe Tester		○	○	○	○			
	Auto-insertion Machine				○	○	○	○	
PCB Drilling Machine			○	○	○	○	○		
Industrial Robots	Cartesian Coordinate Robo			○	○	○	○	○	
	Vertical Articulated Robot					○	○	○	
	Cylindrical Coordinate Robot				○	○	○	○	
Other	Raw Material Processing						○	○	
	Injection Molding Machine						○	○	
	Coordinate Measuring Machine		○	○	○				
	Office Equipment						○	○	
	Machine Vision System		○	○					
Nuclear Power	Control Rod					○	○	○	
	Kinetic Energy Damper							○	
	Aviation Equipment					○	○		

1-8-2 Temperature Control for Lead Accuracy

A) Thermal Deformation

○ Heat-induced thermal

1-Heat generation is inherently unavoidable during ball screw operation. Due to thermal expansion and contraction, the screw fails to achieve required positioning accuracy. The specific thermal elongation of the screw induced by heating can be calculated using the following formula.

$$\Delta L = \alpha \times \Delta t \times L \text{ --- Formula 1.8.2}$$

ΔL : axial elongation of the screw

α : Coefficient of Thermal Expansion (CTE)

Δt : Temperature variation of the screw (ΔT) C°

L : Effective Thread Length

2-Per 1°C temperature rise, the ball screw shaft elongates by 12μm per meter of length. This thermal deformation directly undermines positioning accuracy—even high-precision screws suffer degraded performance due to heat-induced distortion. When operating at high speed or under preload, temperature rise accelerates and thermal displacement increases significantly. Consequently, implementing countermeasures to suppress temperature increases is imperative.

3-Thermal Control Measures for Ball Screws

● Optimize preload force

Control preloading force on ball screws and angular contact bearings to minimize frictional heat generation

● Increase lead size to reduce rotational speed

Select larger screw leads to lower operating RPM while maintaining feed rate.

● Select appropriate lubricant with optimized volume

Choose lubricants compatible with operating conditions and maintain proper replenishment cycles

● Implement external cooling

Apply lubricating oil or cooling air to screw shaft surfaces

● Utilize internal cooling

Circulate coolant through hollow screw shafts for core temperature reduction

4-Mitigation Strategies for Thermal Displacement Effects

● Execute equipment warm-up protocol

Idle-run machinery until thermal equilibrium is achieved before operation

● Implement pre-tensioned screw installation

Apply axial pre-stretch to compensate for thermal expansion trajectories

● Apply real-time thermal compensation

Program control systems with temperature-derived position offset algorithms

● Deploy closed-loop position feedback

Integrate linear encoders or laser interferometers for actual position verification

B) Pre-tension

Heat-induced thermal

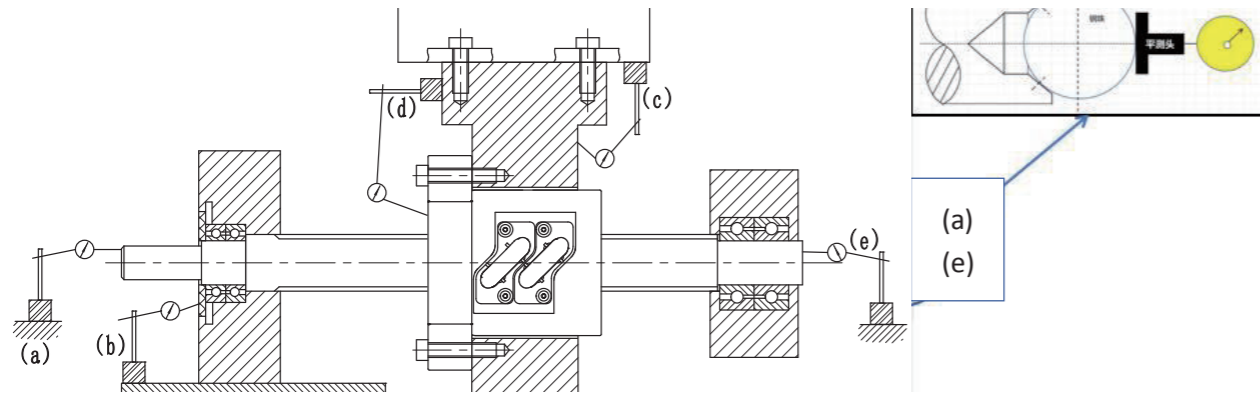

Figure 1.8.1

Pre-stretch Simplified Procedure:

- Mount dial indicators at both ends of the screw shaft
- Level the screw to eliminate gravitational sag
- Tighten locking nut at fixed-end bearing block
- Tighten locking nut at pre-stretch end
- Verify dial reading displacement at fixed end
- If fixed-end dial shows no change: Continue tightening until reaching predetermined value

Thermal Deformation & Preload Calculation

1. Thermal Displacement

Calculations:

$$\Delta L = p \cdot \theta \cdot L \quad \text{----- Formula 1.8.3}$$

ΔL : Thermal Displacement (mm)

p : Coefficient of Thermal Expansion: $12 \times 10^{-6} \text{ m/m} \cdot ^\circ\text{C}$

θ : Average Temperature Rise of Screw Shaft ($^\circ\text{C}$)

L : Screw Shaft Length (mm)

2. Preload

Calculations:

$$F = \Delta L \cdot K_s \quad \text{----- Formula 1.8.4}$$

K_s : Ball Screw Rigidity ($\text{kgf}/\mu\text{m}$) $K_s = \pi d r^2 E / 4L$ F :

Preload (kgf)

d_r : Ball Screw Root Diameter (mm)

E : Elastic Modulus of Steel ($2.1 \times 10^4 \text{ kgf/mm}^2$)

- Revise the target pitch value on the ball screw drawing with thermal error compensation (T+E) based on lead error measurements taken by laser equipment after thermal stabilization.



Figure 1.8.1

1-9 Ball Screw Life Calculation ⑦

1-9-1 Ball Screw Service Life

Ball Screw Life refers to the operational period during which a ball screw, under normal operating conditions, eventually fails due to spalling phenomena or wear-induced loss of accuracy. This duration is categorized as either Fatigue Life or Accuracy Life, depending on the failure mechanism

Basic Static Axial Load Rating (C_{0a})

The Basic Static Axial Load Rating (C_{0a}) of a ball screw is defined as the static load value at which the total plastic deformation at the maximum contact stress point between the balls and raceways reaches 0.0001 times the ball diameter, occurring under static or low-speed operating conditions ($n \leq 10 \text{ rpm}$).

Basic Dynamic Axial Load Rating (C_a)

The Basic Dynamic Axial Load Rating (C_a) is defined as the maximum constant-magnitude axial load, unchanging in direction, that can be sustained by a group of identical ball screws from the same production batch operating under identical conditions for 1 million revolutions, where 90% of the units exhibit no surface fatigue spalling.

$$L^\alpha = \left(\frac{1}{P} \right)^3 \quad \begin{array}{l} L : \text{Life} \\ P : \text{Axial Load} \end{array}$$

Average Load P_e

When the axial load varies over time, the mean load for equivalent fatigue can be calculated using the following formula.

$$P_e = \left(\frac{P_1^3 n_1 t_1 + P_2^3 n_2 t_2 + \dots + P_n^3 n_n t_n}{n_1 t_1 + n_2 t_2 + \dots + n_n t_n} \right)^{\frac{1}{3}} \quad (\text{kgf})$$

Axial Load (kgf)	Rotational Speed (rpm)	Rotational Speed (%)
P ₁	n ₁	t ₁
P ₂	n ₂	t ₂
⋮	⋮	⋮
P _n	n _n	t _n

But $t_1 + t_2 + t_3 + \dots + t_n = 100$

Table 1.9.1 Theoretical lifespan for various purposes

Application	Life (h)
Machine Tool	20000
Machinery Equipment	10000
Automation Equipment	15000
Measuring Equipment	15000

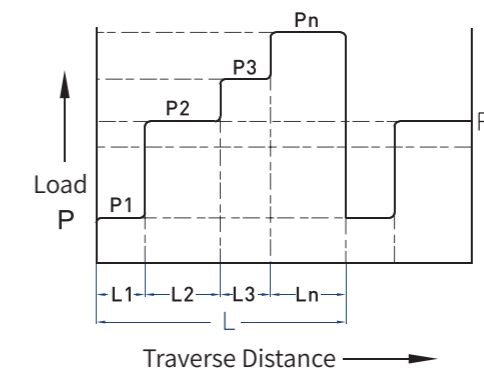

Figure 1-9-1

$$P_e = \frac{2P_{\max} \times P_{\min}}{3} \quad (\text{kgf})$$

P_{max}: Maximize Axial Load (kgf)
P_{min}: Minimum Axial Load (kgf)

Table 1.9.2 Load Factor

Shock and Vibration in Reciprocating Motion	Speed (V)	fw
Minute	Creep Traverse Rate	1 ~ 1.2
	$V \leq 0.25\text{m/s}$	
Small	Low Traverse Rate	1.2 ~ 1.5
	$0.25 < V \leq 1\text{m/s}$	
Middle Traverse Rate	Middle Traverse Rate	1.5 ~ 2
	$1 < V \leq 2\text{m/s}$	
Big	High Traverse Rate	2 ~ 3.5
	$V > 2\text{m/s}$	

Load varies sinusoidally (as shown in Figure 1.9.2)

$P_e \cong 0.65P_{max} \dots \dots$ (Fig 1)

$P_e \cong 0.75P_{max} \dots \dots$ (Fig 2)

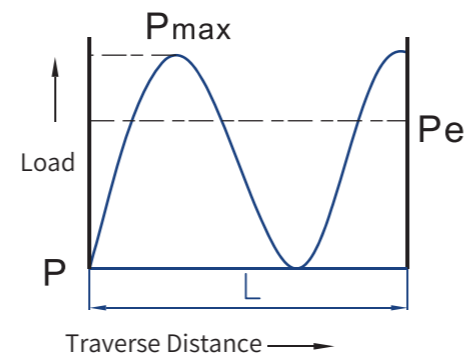

Fig 1

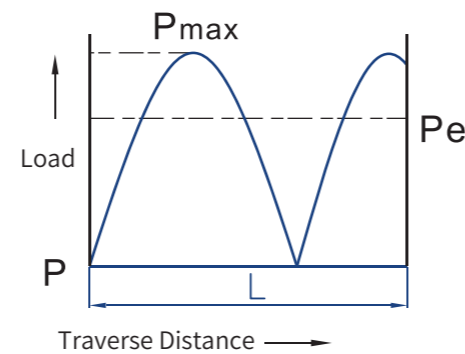

Fig 2

Life Calculation

Formula 1.9.1

$$L = \left(\frac{Ca}{Pa \times fw} \right)^3 \times 10^6$$

Formula 1.9.2

$$L_t = \frac{L}{60n}$$

Formula 1.9.3

$$L_s = \frac{L \times \ell}{10^6}$$

L: Rated Fatigue Life (rev)
 Ls: Traverse Distance Life(km)
 Pa: Axial Load(kgf)

fw: Load Factor(Operating Condition Factor)
 Lt: Lift Time (h)
 Ca: Basic Dynamic Load Rating (kgf)

n : Rotational Speed (rpm)
 ℓ : Lead (m)

Table 1.9.3 Safe Fctor

Equipment	Load Condition	Minimum of fs
Machine Tool	Normal Operation	1.0 ~ 1.3
	Presence of Shock and Vibration	2.0 ~ 3.0
General Machinery	Normal Operation	1.0 ~ 1.5
	Presence of Shock and Vibration	2.5 ~ 7.0

Required Dynamic Load Rating(Ca)
 $Ca = P_e \times f_s$

Required Static Load Rating(Coa)
 $Coa = P_{max} \times f_s$

1-9-2 Ball Screw Life Calculation Example

(I) Introduction to SVB1160 CNC machining center machine

1. Main structural features

The SVB1160 vertical machining center adopts a vertical frame layout. The column is fixed on the bed and the spindle box moving up and down (in the Z direction) along the column and the sliding seats moves longitudinally along the bed (Y direction) and the worktable moves laterally along the slide (X direction).

Linear guide rails are used for all three axes, and rolling friction is used instead of sliding friction enables faster movement speed and meets the requirements of high speed and precision.

The spindle can achieve continuously variable speed within its speed range, using built-in motor coding machine control to achieve spindle orientation and rigid tapping function.



Figure 1-9-2-1 SVB 1160Outline and Internal Structure Diagram

2. Scope of use

It is specially suitable for precision cutting, high-speed, and large-scale processing of non-ferrous metal parts in industries such as general machinery, engineering machinery, and medical equipment.

3. Main design parameters of the machine tool

Table 1.9.4

	Worktable size	mm	600×1360
	T-slot(N×W×D)	mm	5×18×100
	X axis travel	mm	1160
	Y axis travel	mm	620
	Z axis travel	mm	620
	Distance from spindle center to column front	mm	663
	Distanca from spindle end to worktable	mm	150~770
	L×W×H	mm	3740×2620×2930
	Max. load bearing of worktable	kg	900
	Machine weight	kg	700

Table 1.9.5 Processing center parameters

Travel	X axis travel	mm	1100
	Y axis travel	mm	600
	Z axis travel	mm	600
	Distance from spindle center to column front	mm	130-730
	Distance from spindle end to worktable	mm	650
Work table	Worktable size	mm	1200×600
	Max. Load bearing of Worktable	kg	600
	T-slot	mm	5*18
Spindle	Main motor power	kw	11
	Spindle		8740
	Outside Diameter	mm	150
	Spindle Speed	rpm	8000
	Pull Studs		MAS-P40T-1
	Pulling force		8KN
Feed rate	X \ Y \ Z axis	m/min	24/24/20
	Cutting feed rate	mm/min	1-12000
Accuracy	positioning accuracy	mm	±0.008/300
	Repetitive positioning accuracy	mm	±0.006
Other	Machine weight	kg	7300
	Machine tool dimensions	mm	3200×2500×2800

Table 1.9.6 Design Parameter Table

Spindle	Spindle Speed	8000rpm
	Speed selection	Full range programmable
Rapid traverse speed	X axis :	24 m/min
	Y axis :	24 m/min
	Z axis :	20 m/min
Machine tool positioning accuracy	Positioning accuracy	±0.008/300mm
	Repetitive positioning accuracy	±0.006mm

(II) Selection analysis

Known conditions: Based on the usage of the SVB1160 CNC vertical machining center, its known X-axis design conditions are as follows:

1 Working conditions

Table 1.9.7 Working conditions

Installation method	■ Horizontal		Vertical		
Positioning accuracy: ±δ2	6	μm	Repetitive positioning accuracy: ±δ1		
300mmPositioning accuracy: ±δ300	8	μm	8	μm	
Control system:	Semi closed loop system				

2 Operating conditions

Table 1.9.8 Operating conditions

Operating conditions	■ Time proportion method		□ The maximum value method	
Work condition serial number	Axial load(N)	Radial load(N)	feed rate(m/min)	Time proportion(%)
Work condition 1	6000		0.44	80
Work condition 2	0		16	20

3 working parameters

Table 1.9.9 working parameters

Workbench weight : m1	100	kg	Workbench weight : m2	120	kg
Traveler : L	1100	mm	Maximum moving speed of workbench :	24	m/min
Distance between support points: ls	1403	mm	Transmission ratio: l	1	
Maximum acceleration: a	1	M/s2			
Maximum speed of screw: Nmax	2000	R/min			
Working table dynamic friction coefficient : μ	0.01		Working table dynamic friction coefficient : μ	0.02	

4 Design Requirements

Table 1.9.10 Design Requirements

Mileage lifespan :	/	km	Expected lifespan : Lh	23000	h
Accuracy coefficient : fa	0.9		Reliability coefficient : fc		
Static safety factor : fs			Pre load factor : fe	4.5 (Medium preload)	
Load factor : fw	1.5 (Slight impact)		Pre load percentage: %	0.075 (Medium preload)	

(III) Preliminary selection

The process of determining the basic parameters when selecting the X-axis ball screw pair is as follows: SVB1160 CNC vertical machining center positioning accuracy $\pm 0.008/300\text{mm}$, The cutting force is not significant. Applied to the general machinery industry, mainly for cutting parts. Belonging to high-speed and economical CNC machining centers. Choose a connection method with fixed ends for work conditions and product positioning. This structural form elongates through the reserved gap when the screw generates heat during operation. In situations of high precision and speed, it has a high cost-effectiveness. It is a typical structure of a high-speed economical vertical processing center machine.

1. Selection of accuracy level

Given the effective travel of the thread $L_u=1100\text{mm}$ (assuming a nut length of 200), according to the GB/T 17587.3 standard P3 level accuracy $=\text{ep} \pm 0.024/1100\text{mm}$.

According to the accuracy level table of ball screw pairs differentiated by usage, for CNC machining centers, the accuracy of XYZ axis screw pairs is generally selected as P1 to P3.

The final choice is P3 level accuracy.

2. Determine the minimum lead

According to the maximum speed N_{max} of the motor and the maximum speed V_{max} of the worktable, it can be calculated :

$$P_{\text{hmin}} = \frac{V_{\text{max}}}{N_{\text{max}}} = 11\text{mm} = 24 \times 1000 / 2000 = 12\text{mm}$$

3. Determine the type of ball screw pair

Due to the fast forward speed of 24m/min on the X-axis, we have chosen an end plug ball screw pair that is more suitable for high-speed use environments (see Figure 9-2 and Figure 9-3):

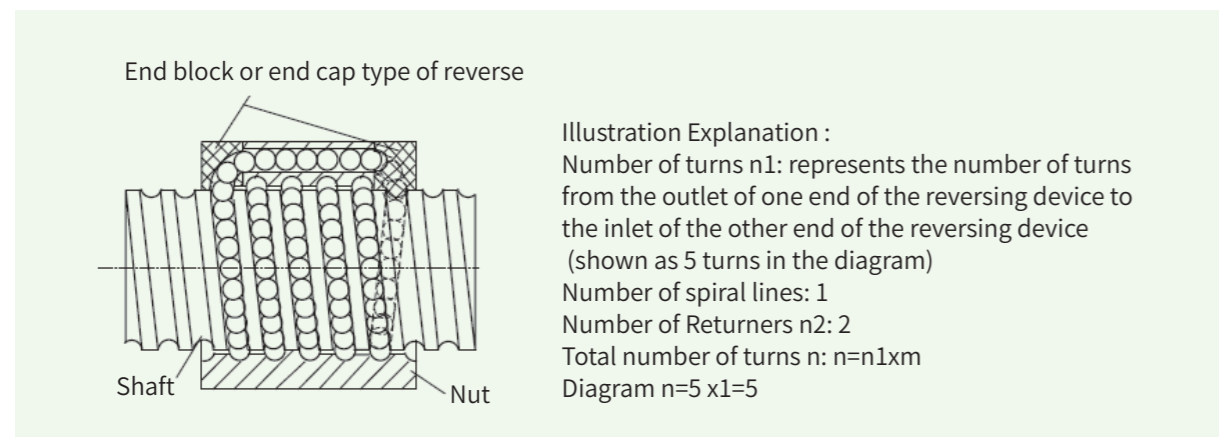

Figure 1-9-2-2 Schematic diagram of end block ball screw pair structure

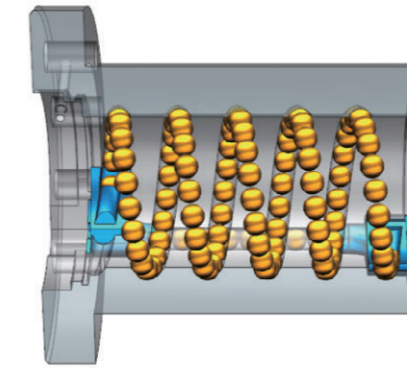

Figure 1-9-2-3 3D diagram of end block reverse structure

This product has the following characteristics:

- High speed. Adopting a special reversing structure to enhance the strength of the reversing structure and meet the requirements of high DN values, this type of screw pair has been tested and found to have a DN value of up to 120000.

- High acceleration. Optimize the reverse circulation structure, reduce the impact of ball bearings on the reverse circulation structure, and achieve instantaneous high acceleration.

Based on the above characteristics, this type of product is widely used in high-speed and high-precision machines such as CNC lathes, vertical machining centers, and horizontal machining centers.

So, the type of X-axis ball screw pair is determined to be an end block high-speed precision ball screw pair, namely DC type. (DFDC X R4012-D1-S-D-PA)

4. Determine the pre tightening type of ball screw pair

The pre tightening method of the X-axis ball screw pair adopts double nut spacer pre tightening, with a simple and reliable structure, good rigidity, and is most suitable for high-speed light load machine tools, which is the most economical.

5. Determine the nominal diameter of the ball screw pair

There are two ways to determine the nominal diameter of a ball screw pair:

- 1) The nominal diameter of the ball screw pair directly affects the rated dynamic load of the ball screw pair. Therefore, we can start from the minimum rated dynamic load of the selected screw pair to determine its nominal diameter range.

- 2) The nominal diameter of the ball screw pair also directly affects the rigidity of the ball screw, so we can also consider the expected rigidity of the selected screw pair to determine its nominal diameter range.

5.1 Determine the nominal diameter range through the minimum rated dynamic load

Firstly, perform force calculation to determine the equivalent speed N_m and equivalent load F_m . According to $P_{\text{hmin}}=11\text{mm}$, the initial lead of the ball screw pair is 12mm.

According to the operating conditions (see Table 9-3), the following can be obtained:

Equivalent speed:

$$N_m = n_1 \times \frac{t_1}{100} = n_2 \times \frac{t_2}{100} = 296 \text{r/min}$$

Equivalent load:

$$F_m = \sqrt[3]{\frac{F^3 n_1 \frac{t_1}{100} + F^3 n_2 \frac{t_2}{100}}{N_m}} = 843 \text{N}$$

Note 1: Due to the use of linear guides in this machine tool, the frictional force caused by radial loads is very small, so it is ignored in this calculation.

Note 2: Due to the small acceleration of the machine tool, the load generated by acceleration is ignored.

Next, determine the minimum rated dynamic load of the X-axis screw pair. The rated dynamic load of the ball screw pair directly affects its service life, so it can be expected that determining the minimum rated dynamic load based on the lifespan. Additionally, for ball screw pairs with preloading, the minimum fixed motion must be determined by the maximum axial load.

Estimate the minimum rated dynamic load based on expected lifespan

$$C_{am} \geq \sqrt[3]{60 N_m L_h} \cdot \frac{F_m f_w}{100 f_a f_c} = 10.4 \text{KN}$$

Among them,

L_h is 23000h;

f_a is the accuracy coefficient, and P3 is taken as 1, as shown in Table 9-6;

f_c is the reliability coefficient. As it is a high-speed and economical CNC machining machine, the reliability is selected based on the most economical 90%. Here, 1 is taken, as shown in Table 9-7;

f_w is the load factor, which is slightly impacted during processing. Here, it is taken as 1.5, as shown in Table 9-8.

Table 1.9.11 Accuracy coefficient table

Accuracy Grade	1,2,3	4,5	7	10
f_a	1.0	0.9	0.8	0.7

Table 1.9.12 Reliability coefficient table

Reliability	0.90	0.95	0.96	0.97	0.98	0.99
f_c	1	0.62	0.53	0.44	0.33	0.21

Table 1.9.13 Load factor table

Load factor	No impact (very stable)	Slight impact	Accompanied by impact or vibration
f_w	1~1.2	1.2~1.5	1.5~2

Estimate the minimum rated dynamic load based on the maximum axial load

$$C_{am} \geq f_e F_{max} = 8.2 \text{KN}$$

$$F_{ma} = F + \mu \cdot (m_1 + m_2) \cdot g \approx 1822 \text{N}$$

Among which,

f_e is the preload coefficient, and since vertical loading generally adopts medium preload (see Table 9-9), it is taken as 4.5 here (see Table 9-10).

F is the axial force (see Table 9-3), the weight of the worktable is m_1 , the maximum mass of the work-piece fixture is m_2 , and the dynamic friction coefficient of the worktable is (see Table 9-4).

Table 1.9.14 Recommendation Table for Pre tightening Force

Preloading	Application occasions
Light preloading	Electric machining machines (EDM, wire cutting), electronics industry, robots, semiconductor equipment, medical devices, experimental instruments, testing equipment
	Non machine tool industry
Medium preloading	Vertical M/C, horizontal M/C, CNC lathe
Heavy preloading	Heavy duty machine tools such as floor boring, Gartry boring and milling machines, large vertical lathes, gear machining machines, etc

Table 1.9.15 Preloading coefficient f_e

Preload type	Light preloading	Light preloading	Heavy preloading
f_e	6.7	4.5	3.4

Table 1.9.16 Rated dynamic load screening table

Specification	Rated dynamic load	Request dynamic load	whether it complies with
May-12	56.1 KN	$\geq 10.4 \text{ KN}$	✓
May-12	63.3 KN		✓
May-12	70.4 KN		✓

From this, it can be concluded that the rated dynamic load of the selected lead screw should meet the following requirements based on the parameters of the DFDC type in the sample (see Table 9-11):

Table 1-9-16 Rated Dynamic Load Screening Table

One of the three specifications of the X-axis ball screw pair can be determined by the minimum rated dynamic load.

5.2 Determine the nominal diameter range through the minimum rigidity of the screw

The maximum allowable axial deformation of the lead screw, δ_m , should simultaneously meet the following requirements:

$$\delta_m \leq (1/3 \sim 1/4) \times \delta_1$$

$$\delta_m \leq (1/4 \sim 1/5) \times \delta_2$$

According to the known conditions in Table 9-1, the repeated positioning accuracy is 0.006mm and the positioning accuracy is 0.008mm. Therefore, the minimum value in the two equations above should be taken :

$$\delta_m = 4\mu\text{m}$$

The calculation formula for the minimum base diameter is as follows:

$$d_{2\min} \geq 2 \times 10 \sqrt{\frac{10F_j \cdot l_1}{\pi \cdot \delta_m \cdot E}}$$

$$= 0.078 \times \sqrt{\frac{\mu_0 \cdot mg \cdot [(1.05 \sim 1.1) \cdot L_u + (10 \sim 14) \cdot P_h]}{\delta_m}} = 12.1\text{mm}$$

In the formula, $d_{2\min}$ - minimum base diameter (mm);

F_j - static friction force (N);

L_1 - maximum distance from the ball nut to the fixed end support of the ball screw (mm);

E - Young's modulus of elasticity ($2.1 \times 10^5 \text{N/mm}^2$);

μ_0 - static friction coefficient. (See Table 9-4); M - Quality of workbench and workpiece fixtures, $m=m1+m2$. (See Table 9-4).

So, by determining the minimum rigidity of the screw, it can be determined that all three specifications in Table 11 can meet the requirements.

6 Preliminary verification

Due to $L_u=1100\text{mm}$, the total length of the screw is generally above 2200. At this time, for ball screw pairs with diameters of 32 and 40, the aspect ratio is close to or exceeds 60 times. According to relevant host design experience, an excessively large aspect ratio can cause sagging problems when using ball screw pairs, limit the rapid movement, and result in vibration during high-speed rotation. Therefore, the maximum speed verification is first carried out for diameters 32, 40, and 50.

6.1 3212 specification

$$n_{cr} = \lambda_2 \cdot \frac{d_1}{l_{cr}^2} \cdot 10^7 = 903\text{r/min}$$

Table 1.9.17 Critical speed coefficient

Installation method	
Fixed - Free	3.4
Support - Support	9.7
Fixed - Support	15.1
Fixed - Fixed	21.9

In the equation,

N_{cr} - critical speed (rad/min);

D_1 - screw base diameter=26.4mm;

λ_2 - coefficient related to installation spacing (see Table 9-12);

L_{cr} - distance of screw support point=1403mm.

Due to $N_{\max} \geq n_{cr}$, the critical speed verification of 3212 specification is not qualified.

$$n_{cr} = \lambda_2 \cdot \frac{d_1}{l_{cr}^2} \cdot 10^7 = 1177\text{r/min}$$

6.2 4012 specification

In the equation,

N_{cr} - critical speed (rad/min);

D_1 - Screw base diameter=34.4mm;

λ_2 - coefficient related to installation spacing (see Table 9-12);

L_{cr} - distance of screw support point=1403mm.

Due to $N_{\max} \geq n_{cr}$, the critical speed verification of 4012 specification is qualified.

$$n_{cr} = \lambda_2 \cdot \frac{d_1}{l_{cr}^2} \cdot 10^7 = 1503\text{r/min}$$

6.3 5012 specification

In the equation,

N_{cr} - critical speed (rad/min);

D_1 - screw base diameter=44.4mm;

λ_2 - coefficient related to installation spacing (see Table 9-12);

The distance between the l_{cr} screw support point is 1403mm. Due to $N_{\max} \geq n_{cr}$, the critical speed verification of the 5012 specification is qualified.

(IV) Performance verification

According to 6.1, 6.2, and 6.3, the final selected ball screw pair specification is DFDC4012-D1. Then perform performance verification on it. The verification process is as follows below:

1 Pre tightening force

$$(1) F_p = \frac{1}{3} F_{\max} = \frac{1822}{3} = 607.3\text{N}.$$

(2) Due to the low cutting force of the machine tool, it is not recommended to use too much pre tightening force. Therefore, it is recommended to use 5% $Ca=2600\text{N}$, choose the one with the larger preload force of 2600N.

2-way compensation and pre tension force

For closed-loop systems, the use of ball screw pairs with fixed end structures generally considers stroke compensation and pre tension.

3 Stiffness verification

Minimum compressive stiffness of screw:

$$R_{s\min} = 165 \cdot \frac{d_c^2}{l_{s\max}} = 166\mu\text{m/N}$$

In the equation,

R_s - Tensile and compressive stiffness of the screw ($\mu\text{m/N}$);

L_s - the distance from the nut to the fixed end (mm), and the minimum stiffness occurs when the dis-

tance between the nut and the fixed support end is maximum; when the distance between the nut and the fixed support end is minimized, it becomes maximum rigidity;
 $d_c = D_{pw} - D_w \cdot \cos\alpha$ - Bottom diameter of contact point of ball screw (mm);
 The maximum compressive stiffness of the screw is:

$$R_{smax} = 165 \cdot \frac{d_c^2}{l_{smin}} = 5400 \mu m / N$$

The maximum system stiffness of the ball screw using the simplified algorithm proposed for optimizing design selection is:

$$R_{max} \approx \frac{R_{smax}}{3} = 1800 N / \mu m$$

The minimum system stiffness is:

$$R_{max} \approx \frac{R_{smax}}{3} = 55 N / \mu m$$

Minimum system stiffness required by design

$$R_0 \approx \frac{1.6 \mu_0 \cdot mg}{\delta_1} = 440 N / \mu m$$

In the equation,

μ_0 - static friction coefficient. (See Table 9-4;)

M - Quality of workbench and workpiece fixtures. $m = m_1 + m_2$. (See Table 9-4;)

In summary, R_{min} is greater than R_0 , therefore the stiffness check is qualified.

4 Accuracy verification

$$\delta_k = \mu_0 mg \left(\frac{1}{R_{min}} - \frac{1}{R_{max}} \right) = 0.02 \times 220 \times 9.8 \times \left(\frac{1}{55} - \frac{1}{1800} \right) \approx 0.76 \mu m$$

For the validation of closed-loop control systems:

$$e_p = 16 \mu m \leq 0.8(\delta_2 - \delta_k) = 0.8 \times (60 - 0.76) = 47.4 \mu m$$

δ_2 - Positioning accuracy, (see Table 9-2).

Accuracy verification is qualified.

5 Critical compression load verification

$$F_c = K_1 K_2 \frac{d_2^4}{l_s^2} \times 10^5 \geq F'_{max} = \frac{1}{3} \times 4 \times \frac{44.4^4}{2000^2} \times 10^5 \approx 117500 N > 1822 N$$

K_1 - Safety factor (see Table 9-13);

K_2 - Support coefficient (see Table 9-14);

l_s - The distance between the screw support points is 2100mm.

Table 1.9.18 Safety factor table

Safety factor	Vertical installation	Horizontal installation
K1	0.5	0.33

Table 1.9.18 Safety factor table

Supporting type	Fixed - Support	Support - Support	Fixed - Free	Fixed - Fixed
K2	2	1	0.25	4
Ks	2.5	1	0.125	5

Therefore, the critical compression load verification is qualified.

6 Critical speed verification

3.6.3 Verified and qualified.

7 DN value verification

After calculation:

$$(d_2 + D_w) \cdot n_{max} \leq DN_0 = 50.8 \times 1333 = 67716 \leq DN_0 = 150000$$

Therefore, the DN value verification is qualified.

d_2 - Bottom diameter of ball screw pair thread

D_w - Ball diameter

(V) Life Calculation

$$L = f_c \left(\frac{C_a}{F_m f_w} \right)^3 \cdot 10^6 = 70432 \times 10^6 \text{ convert to}$$

$$L_t = \frac{L}{60n} = 4 \times 10^6 \text{ h}$$

In the formula,

L - rated fatigue life, unit: r;

f_c - reliability coefficient, see Table 9-7, take 1;

C_a - Basic rated dynamic load, unit: N;

F_m - equivalent load, unit: N;

f_w - load factor, see Table 9-8, taken as 1.5;

L_t - lifespan time, in hours;

N - Rotation speed, unit: r/min.

Note: For CNC lathes used for cutting aluminum alloys, if the machine length is long, due to the limitation of the maximum speed, the lead screw is generally chosen to be thicker, so the theoretical lifespan is far exceeds actual needs.

(VI) Selection Conclusion

In summary, the DFDCXR4012 ball screw pair meets the selection requirements for the X-axis ball screw pair in this CNC machining center. Therefore, the final X-axis screw selection result is DFDCXR4012-D1-G1619/1373-P2C3.

6. Based on the speed and load torque, preliminarily select the motor

Preliminary selection of Yaskawa SGM7G13A motor (parameters shown in Table 1-9-20):

Table 1.9.20 Motor Parameter Table

Voltage		200V			
Model SGM7B-		03A	05A	09A	13A
Rated output ¹	kW	0.3	0.45		
Rated torque ^{1, 2}	N-m	1.96	2.86		
Instantaneous maximum torque ¹	N-m	5.88	8.92		
Rated current ¹	Arms	2.8	3.8		
Instantaneous maximum current ¹	Arms	8.0	11		
Rated speed ¹	min ⁻¹	1500			
Maximum speed ¹	min ⁻¹	3000			
Torque parameters	N-m/Arms	0.776	0.854	0.859	0.891
rotor inertia	×10 ⁻⁴ kg·m ²	2.48(2.73)	3.33(3.58)	13.9(16.0)	19.9(22.0)

The rotational speed meets the usage requirements, $N_m \geq N$

The rated torque meets the usage requirements, $T_n \geq (T_{pmax} + T_1 + T_u) \cdot i$

The peak torque meets the usage requirements, $T_{NMAX} \geq (T_{pmax} + T_2 + T_u) \cdot i$

1-10 Precautions for using ball screw ⑧

1-10-1 Nut disassembly and assembly

Precision components and require special attention to the following:

Avoid Impact on Threaded Surfaces: Do not allow sharp objects or cutting tools to strike the threaded surfaces.

Prevent Separation or Over-Travel: Ensure the nut does not detach from the screw or exceed the allowable travel. If the nut is separated, the balls may dislodge. If this occurs, do not reassemble forcibly, as it may cause the ball screw to seize. Contact our specialist for assistance (as shown in Figure 1.10.1).

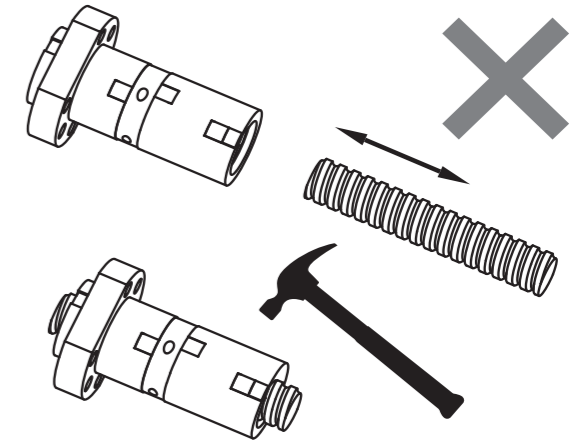

Fig 1.10.1 Error Examples

1-10-2 Lubrication

Lubrication Requirements for Ball Screw

When using the ball screw, it is essential to ensure proper lubrication. Insufficient lubrication can result in metal-to-metal contact, leading to increased friction and wear. This may cause operational failures or shorten the service life of the ball screw.

Lubricants for Ball Screws: Oils vs. Greases

Ball screws primarily use two types of lubricants: oil and grease. In maintenance, grease tends to cause a linear increase in dynamic friction torque as rotational speed rises. For speeds exceeding 3-5 m/min, oil lubrication is generally more effective. However, grease has also been used successfully at speeds up to 10 m/min in certain cases. For cost-sensitive applications, grease may be the more economical choice. To optimize performance, oil lubrication at around 5 m/min is often the best compromise. Table 1.10.1 represents general indicators for the inspection and replenishment intervals of lubricants. During replenishment, old lubricant paste adhering to the screw shaft must be wiped off before applying new grease.

Table 1.10.1 Inspection and Replenishment Intervals of Lubricants

Lubrication Methods	Inspection Time Interval	Inspection Item	Replenishment or Replacement Interval
Automatic Interval Lubrication	Weekly	Oil volume and foreign matter	Supplement based on consumption during each inspection
Grease	Once every two to three months	Dust, iron filings, and others	Supplement the situation with each inspection and replace it annually
submerged lubrication	Before starting up every day	Oil gauge height	Supplement appropriately according to the oil level during each inspection

1-10-3 Protective measures

During the use of ball screw, moisture, cutting fluid, chips, and other foreign objects should be avoided from entering the raceway. When foreign objects enter, it will cause 1. abnormal noise 2. shaking 3. insufficient accuracy 4. jamming and other situations, which will affect the normal use of ball screws. SHAC's nuts are equipped with dust-proof sealing rings at both ends, which can prevent some foreign objects from entering the inside of the nut. If there is a lot of dust and debris in environments such as woodworking machine, stone processing copper and aluminum parts, additional protective accessories must be added. Folding expansion sleeves or spiral expansion tubes can be installed on the screw to protect it.

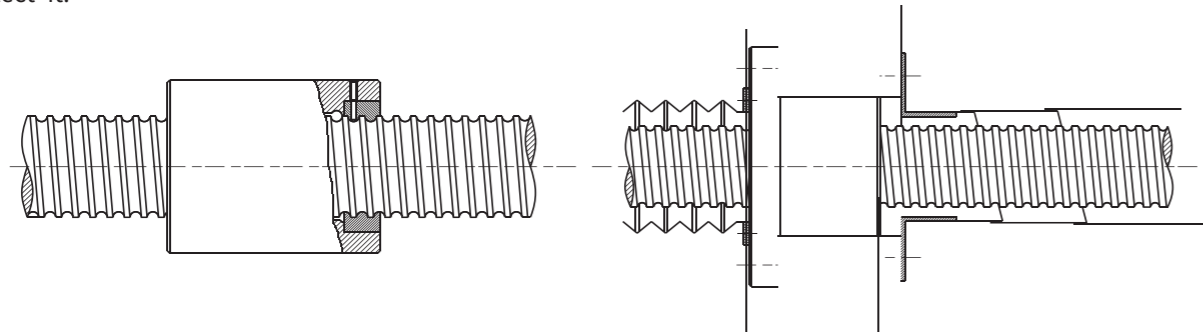

Fig 1.10.2 Dust prevention mechanism

1-10-4 Partial load (Radial force)

As shown in Figure 1.10.3, when the coaxiality between the nut and the lead screw is insufficient, there may be: 1. a feeling of unsmooth rotation, 2. abnormal noise, 3. temperature rise of the lead screw, etc. This is due to the phenomenon of biased load, which is significantly characterized by a large difference in smoothness between unloaded and assembled. In most cases, it is caused by the improper installation of the nut flange combined with the nut seat, and the excessive runout of the flange is also one of the factors.

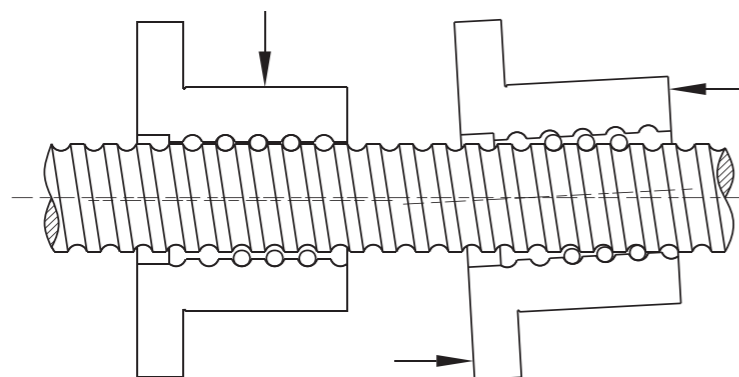

Fig 1.10.3 Partial load

1-10-5 Shaft end machining

1. If you choose ball screw with internal circulation or end cap circulation, the end thread of the screw must be threaded and the maximum shoulder size must be smaller than the base diameter. If the shoulder size is required to be larger than the root diameter, it is also acceptable, but there must be a threaded thread left on the shoulder for easy nut installation. As shown in Figure 1.10.4 below.
2. During screw heat treatment, the thread teeth near the shoulder must be kept soft for 10-20mm in length to facilitate shoulder machining. This area will be marked on the drawing, as shown in Figure 1.10.5. If you have special requirements, please inquire with SHAC business personnel when placing an order.

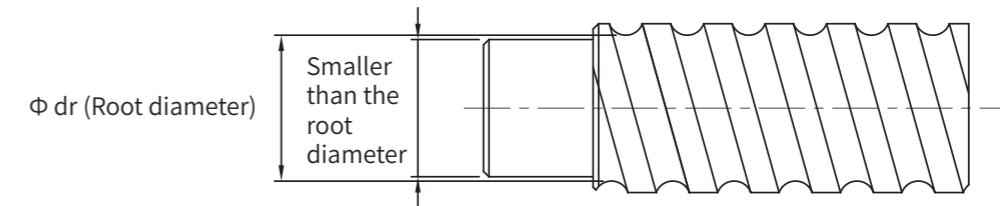

Figure 1.10.4 Specification for shaft end machining

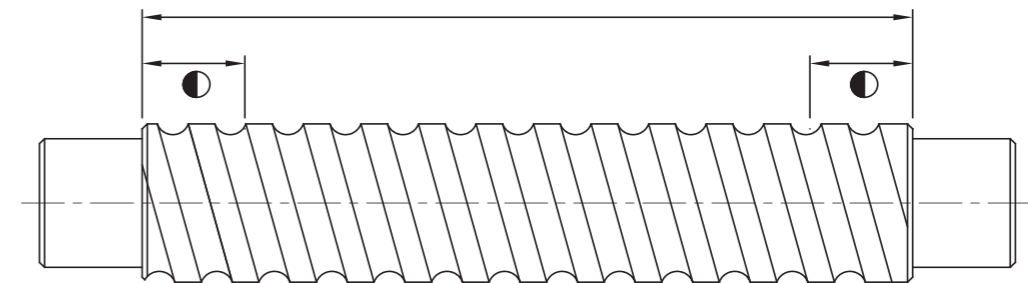

Figure 1.10.5 Effective heat treatment range of screw

If the product you subscribed for is a conversion grade single out nut, please follow the steps below to assemble it:

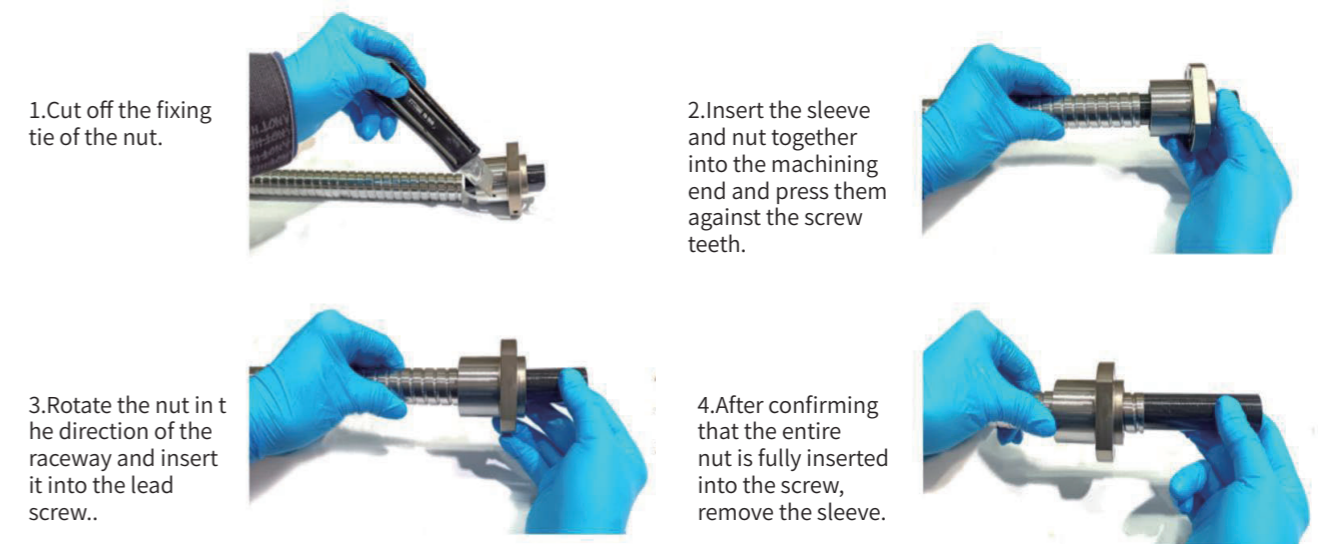

Figure 1.10.6

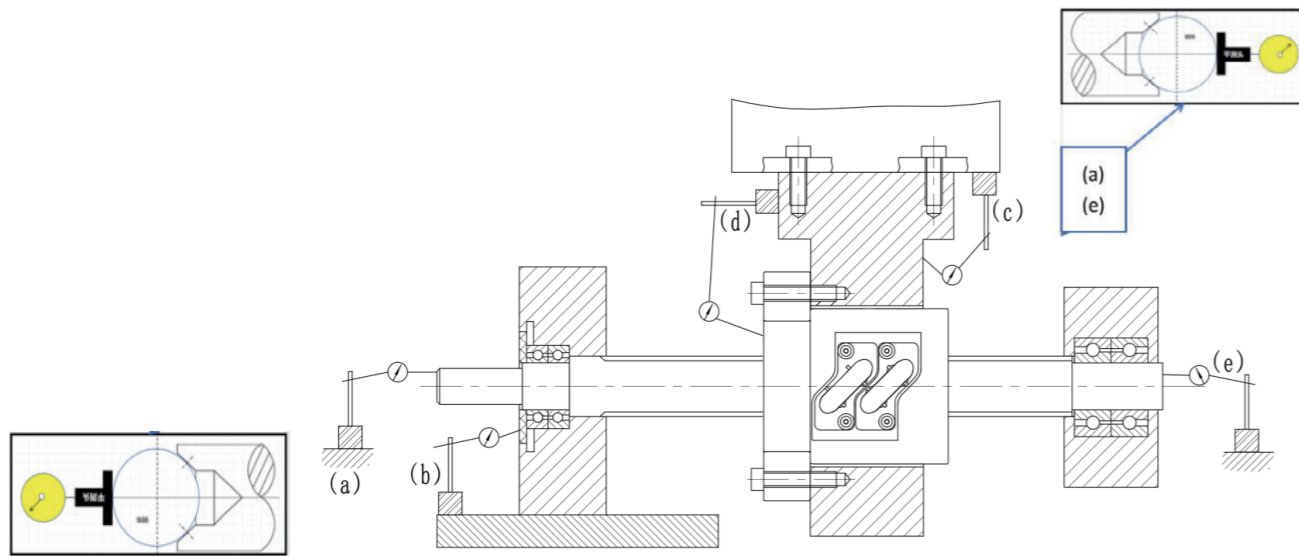

Figure 1.10.7 Axial clearance verification diagram

2 Comprehensive accuracy after installation of ball screw

2-1 Axial clearance (Install)

A) As long as the screw support mode adopts a locking nut and paired bearing fixing method, in order to avoid axial clearance after the installation of ball screws with preload nuts, a 60 degree angular contact bearing (or a combination of one bearing that fully bears axial force and the other bearing that fully bears radial force) must be used to confirm that the locking nut can compress the bearing.

B) After the installation of the screw, a detection structure as shown in the above figure 1.10.7 (page 31) is erected at both ends, and the gauge data is read when the left and right displacement is carried by the nut.

C) The axial clearance may also increase in value due to insufficient rigidity of the bearing seat (b) and nut seat (c), when added together.

2-2 Reverse gap (laser detection)

The parallel pitch error indicates that the reverse clearance is basically consistent throughout the entire stroke. If multiple measurements are stable, the reverse clearance of the shaft can be eliminated through compensation. If the reverse clearance is large, the mechanical structure of the screw should be pre tightened and calibrated to make the reverse error curve coincide with the forward error curve, thereby eliminating the machine tool's reverse clearance.

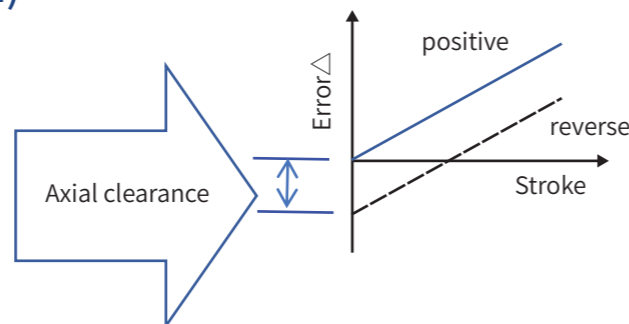

Figure 2.2.1

2-3 Reproducibility of lead accuracy (laser detection)

Repetitive positioning accuracy: Measurements are taken at any three positions near the midpoint and both ends of each coordinate stroke. Fast movement positioning is used for each position, and the positioning is repeated seven times under the same conditions to measure the coordinate values of the positioning points and calculate the maximum difference in readings. The maximum difference of 1/2 among the three positions is taken as the \pm sign and used as the repeated positioning accuracy for that coordinate.

The following figure 2.3.1 shows the continuous testing of the laser instrument twice round trip during a certain stroke after the installation of the ball screw. (You can also take the average of seven round trips back and forth)

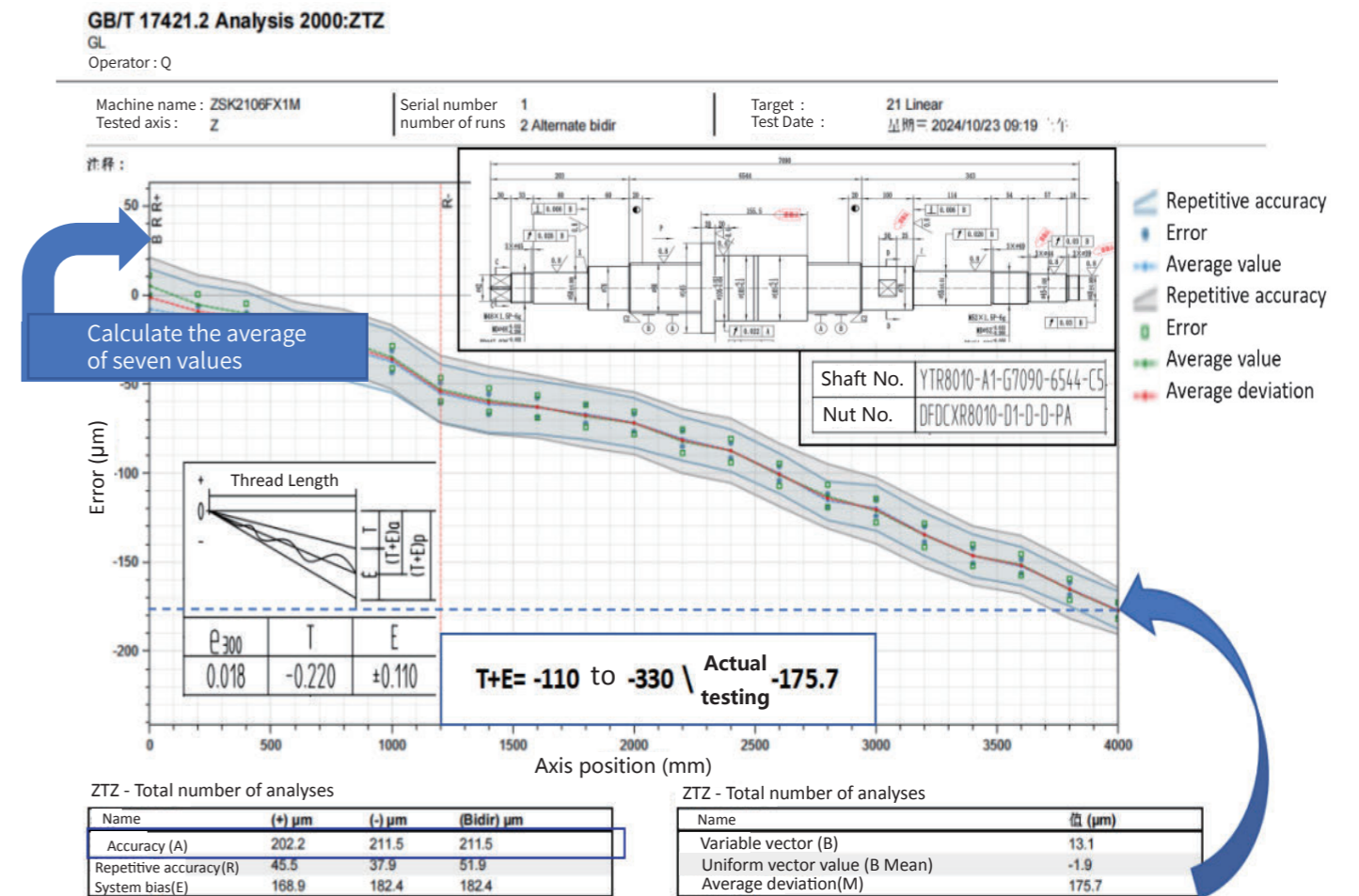

Figure 2.3.1

2-4 Circular accuracy detection (laser detection)

Cross quadrant problem

Due to factors such as reverse clearance friction during the transmission process of the machine tool feed axis, the motor lags behind when running in reverse, resulting in uneven and obvious stripes on the cutting edge at the cross quadrant. This phenomenon is particularly prominent in high gloss machining processes. Usually prone to occur at quadrant switches! (Figure 2.4.1 on page 34)

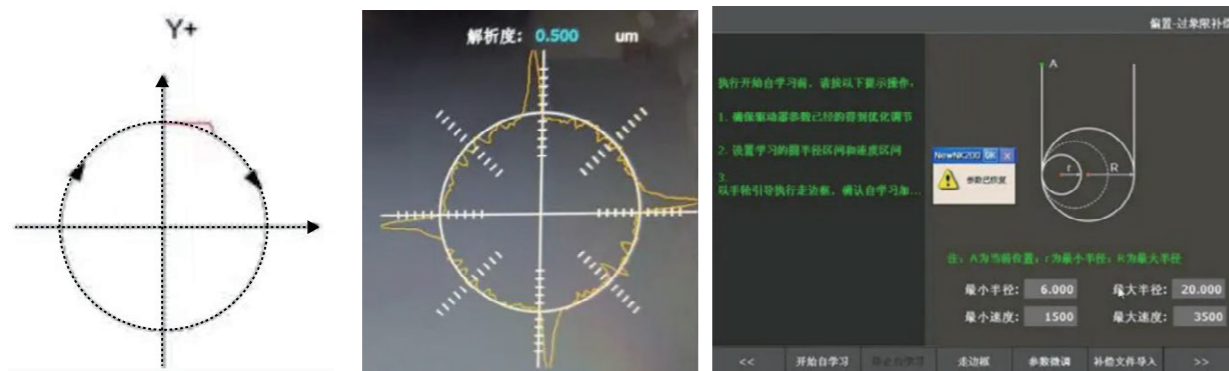

Figure 2.4.1

When the ball screw have pressure setting, this phenomenon is usually caused by improper installation. Most of them use non 60 degree angular contact bearings or locking nuts to fix the bearings in place.

2-5 The key to prestretching (Figure 2.5.1)

When the prestretching operation is not done properly, there will be a misconception that the results of the prestretching operation are the same, which will also affect the accuracy performance of the equipment.

The biggest problem is usually the implementation of prestretching operations without flattening the sagging screw due to its own weight!

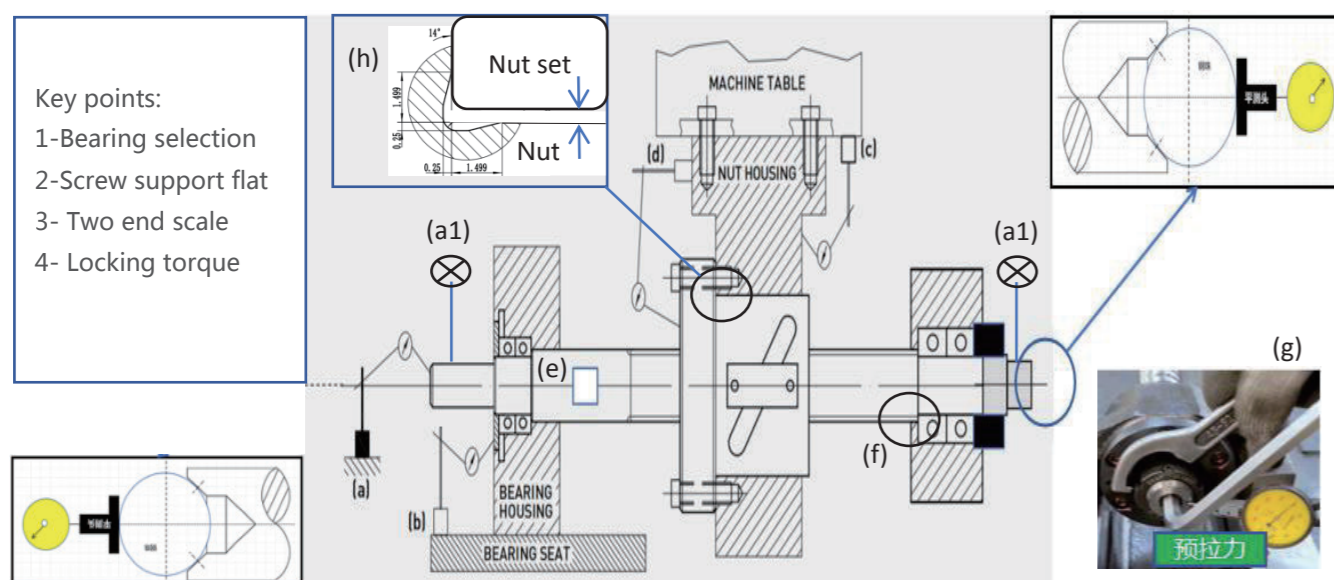

Figure 2.5.1

a) Testing reference point b) Bearing seat rigidity c) Nut seat rigidity d) Nut clearance
e) Fixed key way f) Semi fixed gap g) Pretension h) Anti interference gap a1) Verification outer diameter

3 Abnormal operating factors and elimination

In the 21st century, with the deepening of industrialization, the traditional transmission role of ball screws has gradually been replaced by ball screws. These components that transmit power and control critical accuracy can be seen everywhere in various industries. In the design and application process, there are often problems with design and installation accuracy such as pre pressure, sound, thermal displacement, and reproducibility, which prevent ball screws from developing high-precision and long-life characteristics.

Analyze from four perspectives:

3-1 Poor accuracy

3-1-1 Positioning accuracy

The accuracy problem of equipment occurs frequently in axial clearance. When the nut is not preloaded or the preload is insufficient, a gap will be generated between the screw and the nut, which leads to insufficient accuracy of the equipment. It can be determined that the nut is not preloaded by not feeling torque when turning the lead screw and nut, or by the nut drooping in the vertical direction due to its own weight in the absence of a dust cover.

3-1-2 Backlash

Precision equipment requires precision for both forward and reverse movement. When there is a gap between the nut and displacement reversal due to preloading, the correctness of the bearing needs to be considered. Should we use the commonly used 60 degree angular contact bearing? There will be varying degrees of clearance when contacting bearings from other angles!

3-1-3 Circular exceeding tolerance

When the machine tool has poor circular accuracy, it is usually when the horizontal XY axis moves relative to each other, and there is a gap between one or two axes at the same time. Especially on the circular curve graph, high convex points can be seen when switching between the four quadrants. By determining which quadrant it is in, it can be determined whether the problem is with the X or Y axis.

3-1-4 Insufficient rigidity

The diameter to length ratio design of ball screws has a significant impact on rigidity. The smaller the diameter to length ratio, the higher the rigidity. Conventional designs must be below 60. If the diameter to length ratio is too large, it will cause the self weight of the screw to sag. It is also necessary to avoid weak steel support methods to avoid more fragile stacking situations.

3-1-5 Thermal displacement

The main reasons for the heating of the screw include friction, excessive load, and poor lubrication. During the operation of the screw, friction generates a large amount of heat, especially during the movement between the screw and the nut, which may be caused by surface wear of the screw, thread deformation, or excessive friction of the nut. SHAC will provide appropriate nut preload for different device applications and confirm compliance with drawing requirements before shipment. Therefore please provide detailed equipment operation information when you make a purchase.

3-2 Poor operation

3-2-1 Processing problem

- Poor surface roughness of the ball screw raceway will cause the steel ball to move on uneven surfaces, resulting in poor operation.
- The true roundness of ball screws, steel balls, and raceways, as well as nuts and screws, is a continuous circle on the pitch diameter of the screw. Therefore, high requirements are placed on the true roundness during machining and grinding to avoid vibration caused by inconsistent contact between steel balls and raceways.
- The lead or pitch diameter of ball screws is the most important precision control and presentation in machining operations. If there are not enough precise dimensions, it will directly affect the performance of the operation process.
- The assembly of the reverser, the combination of the nut and the reverser, is the key to determine the quality of the screw operation.

3-2-2 Foreign Object

Ball nuts have a more complex operating structure than regular bearings, and any foreign objects entering the nut that obstruct operation will directly cause malfunctions.

3-2-3 Adjustment Issues

The zero clearance ball screw with preloading requires high parallelism during installation, and an error of less than one thread per meter is widely recognized. Different equipment also has its own suitable specifications.

3-2-4 Component Failure

The parts of ball nuts are easily affected and damaged by external forces, which directly affects their operation. For example, damage to the reverser will directly cause discomfort.

3-2-5 Lubrication Issues

Good lubrication has always been a key element in the operation of ball nuts, and it is also a way to avoid poor operation.

3-3 Breakage and damage

3-3-1 Screw fracture

For the intersection of the outer diameters at the end of the shaft, a circular arc angle should be designed as much as possible to avoid stress concentration (Figure 3.3.1) on page 37.

3-3-2 Steel Ball Damage

The hardness of steel balls is higher than that of screw nuts, but their volume is the smallest. When exposed to high temperatures, they will become brittle and break under high pressure caused by metal thermal expansion and contraction.

3-3-3

Ball screws do not bear radial forces at all, and the eccentric torque caused during installation can generate abnormal shear stress, leading to damage of the screw (Figure 3.3.3) on page 37.

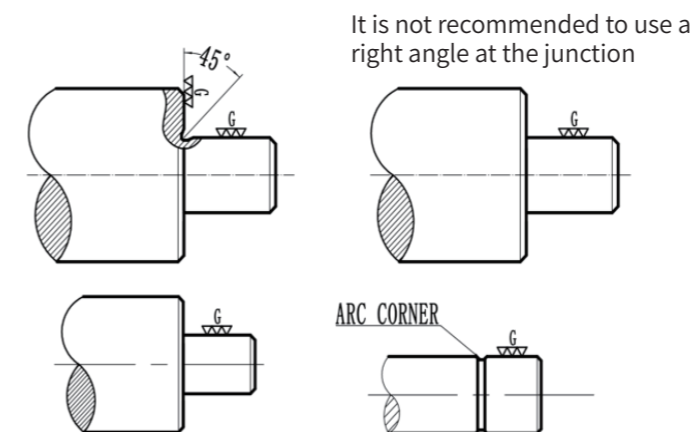

Figure 3.3.1

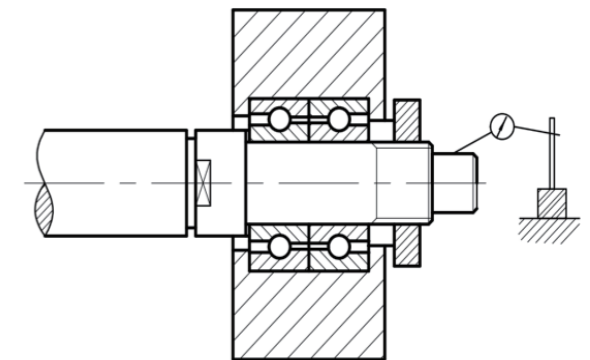

Figure 3.3.3

3-4 Areas prone to abnormalities

There are several parts in the structure of ball screws that are prone to abnormalities:

- Establish the structure shown in Figure 3.4.1 (e) If the nut, nut seat, and bearing have been correctly installed and fixed, the variation here will not exceed 0.003mm (3 microns).
- The structure shown in Figure 3.4.1 a. should also be established at the end of the screw motor (a). When there is no change in the screw rotation gauge, if there is a value, it indicates that the bearing is not completely fixed or the bearing is not paired with a 60 degree angular contact bearing.
- For the detection of bearing seat rigidity, the mode (b) can be set, and when the screw is driven, this gauge cannot display any values.
- The gap between the nut seat and the nut can be set in the mode shown in (d). When the screw is driven, no value should appear on this gauge.
- The rigidity detection of the nut seat can be set as (c) mode, and there should be no numerical values on this gauge between the bed and the nut seat.

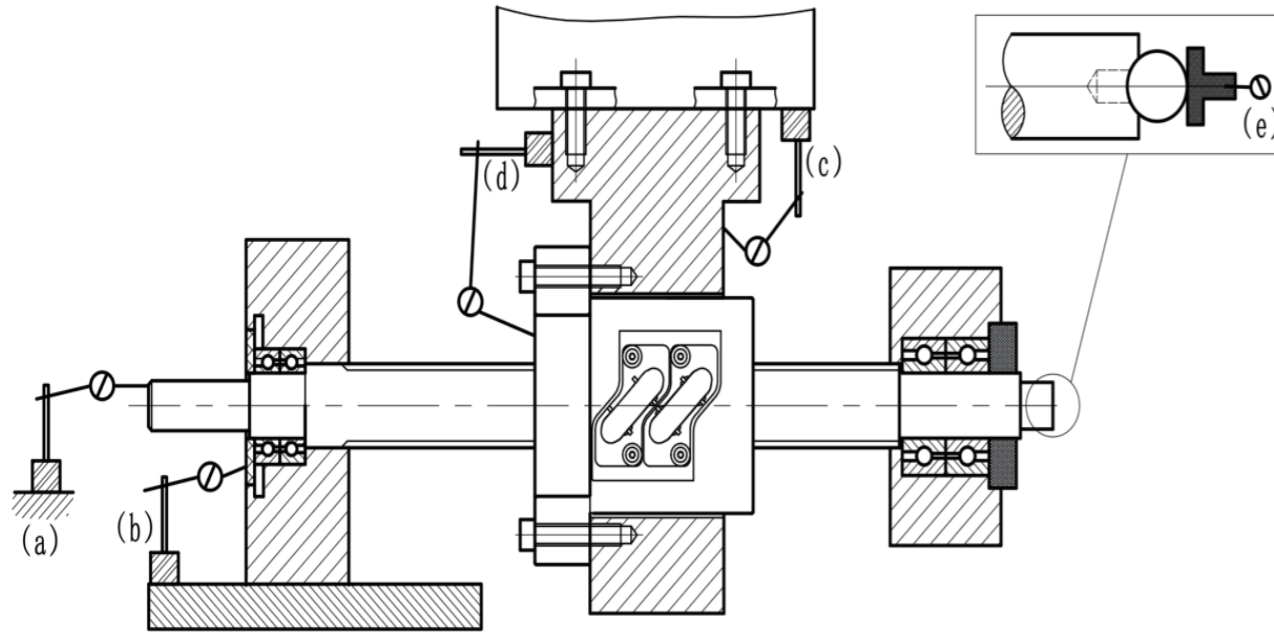

Figure 3.4.1

4. Selection verification of ball screw

Confirm the sequence

How do you further confirm the correctness of the selected ball screw specifications and models that may be suitable?

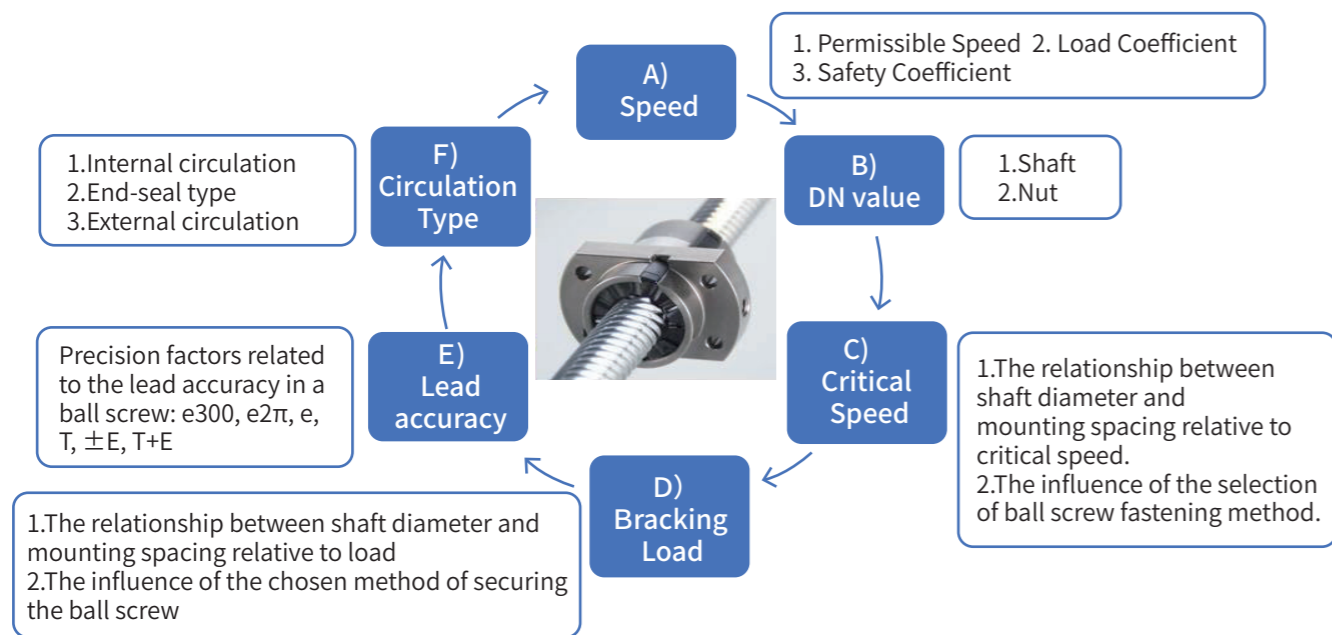

Figure 4.1.1

4-A. Velocity

For most equipment, speed also represents efficiency. The speed of the equipment is directly related to the motor speed and the lead of the screw. To increase speed, it is necessary to increase the motor speed or increase the lead of the screw. Designers can adjust according to the desired purpose.

$S = L / 1000$ (RPM), where S represents the displacement speed per minute, L denotes the lead (mm), and RPM stands for the motor's revolutions speed per minute.

Given the focus on safety in equipment, it is necessary to calculate the permissible speed, load factor, and safety coefficient.

Formula: (4-A-1, 4-A-2, 4-A-3)

4-A-1 Allowable speed

This speed is termed the critical speed when the rotational speed of a ball screw reaches a specific value which will effect normal operation due to the resonance occurs with permissible speeds being below 80% of the critical speed.

A graph showing permissible speed variations for ball screw, based on screw outer diameter and mounting method, is presented in Fig. 1.4.17. on page 42.

If operation occurs exactly at the critical speed, resonance can be eliminated by altering the screw's natural frequency through the addition of a support bearing in the middle of the screw.

$$n = \alpha \times \frac{60 \lambda^2}{2 \pi L^2} \sqrt{\frac{E I g}{\gamma A}} = f \frac{d r}{L^2} \times 10^7 (\text{rpm})$$

n: permissible speed at dangerous speed

α : Safety factor (take $\alpha=0.8$)

I: Minimum secondary torque for threaded shaft cross-section

$$I = \frac{\pi}{64} d r^4 (\text{mm})^4$$

E: Longitudinal elasticity coefficient ($E=2.1 \times 10^4 \text{kgf/mm}^2$)

dr: Thread bottom diameter (mm)

g: Gravitational acceleration

L: Installation spacing (mm)

γ : Material density

A: Threaded shaft cross-sectional area

f_{γ} : Determined based on threaded shaft fixing method

Support—Support $f=9.7$ ($\lambda=\pi$)
 Fixed—Support $f=15.1$ ($\lambda=3.927$)
 Fixed—Fixed $f=21.9$ ($\lambda=4.73$)
 Fixed—Free $f=3.4$ ($\lambda=1.875$)

4-A-2 Load factor (same on page 24)

Table 1.9.2 Load Factor

Shock and Vibration in Reciprocating Motion	Speed (V)	fw
Minute	Creep Traverse Rate	1 ~ 1.2
	$V \leq 0.25\text{m/s}$	
Small	Low Traverse Rate	1.2 ~ 1.5
	$0.25 < V \leq 1\text{m/s}$	
Middle Traverse Rate	Middle Traverse Rate	1.5 ~ 2
	$1 < V \leq 2\text{m/s}$	
Big	High Traverse Rate	2 ~ 3.5
	$V > 2\text{m/s}$	

Load varies sinusoidally (as shown in Figure 1.9.2)

$$Pe \doteq 0.65P_{max} \dots \dots \text{ (Fig 1)}$$

$$Pe \doteq 0.75P_{max} \dots \dots \text{ (Fig 2)}$$

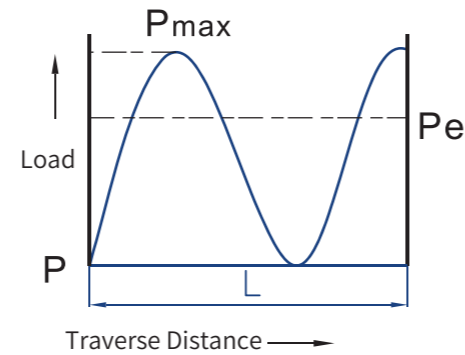

Fig 1

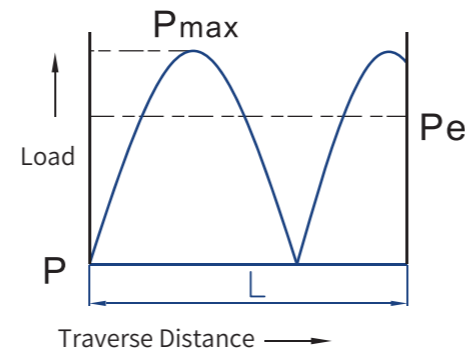

Fig 2

4-A-3 Safety factor

Table 4.1.1 Safe Factor

Equipment	Load Condition	Minimum of fs
Machine Tool	Normal Operation	1.0 ~ 1.3
	Presence of Shock and Vibration	2.0 ~ 3.0
General Machinery	Normal Operation	1.0 ~ 1.5
	Presence of Shock and Vibration	2.5 ~ 7.0

Required Dynamic Load Rating(Ca)
 $Ca = Pe \times fs$

Required Static Load Rating(Coa)
 $Coa = P_{max} \times fs$

4-B DN Value

Another important parameter that determines the maximum rotational speed of the screw is D, the pitch circle diameter (typically measured as the screw's outer diameter for convenience), and N, the screw speed in revolutions per minute (rpm).

Ball screws have corresponding DN values for both the screw and nut. Exceeding these values during equipment operation can easily lead to abnormal phenomena such as vibration and noise.

4-B-1 DN Value of Shaft

The simple calculation for the DN value of a lead screw is the outside diameter value (mm) multiplied by the motor's maximum speed (rpm).

$$\text{Precision Grade (above C7)} \\ N \leq \frac{70000}{D}$$

4-B-2 DN Value of Nut

The DN value of the nut is typically determined by the design of its return system.

SHAC has developed a product with a DN value of 120,000 to meet the market demand for high-speed equipment.

$$\text{Transmission Grade (C10)} \\ N \leq \frac{50000}{D}$$

4-B-3 Effective stroke

The travel size of the equipment often determines its added value, as a broader working range can create greater profitability. Therefore, establishing an effective travel setup requires further evaluation, typically referring to "effective travel" or the travel during operation. The working travel calculation formula is $L - M$ (unit: mm).

In practical use, two to three lead lengths are reserved at both ends of the travel as buffer zones.

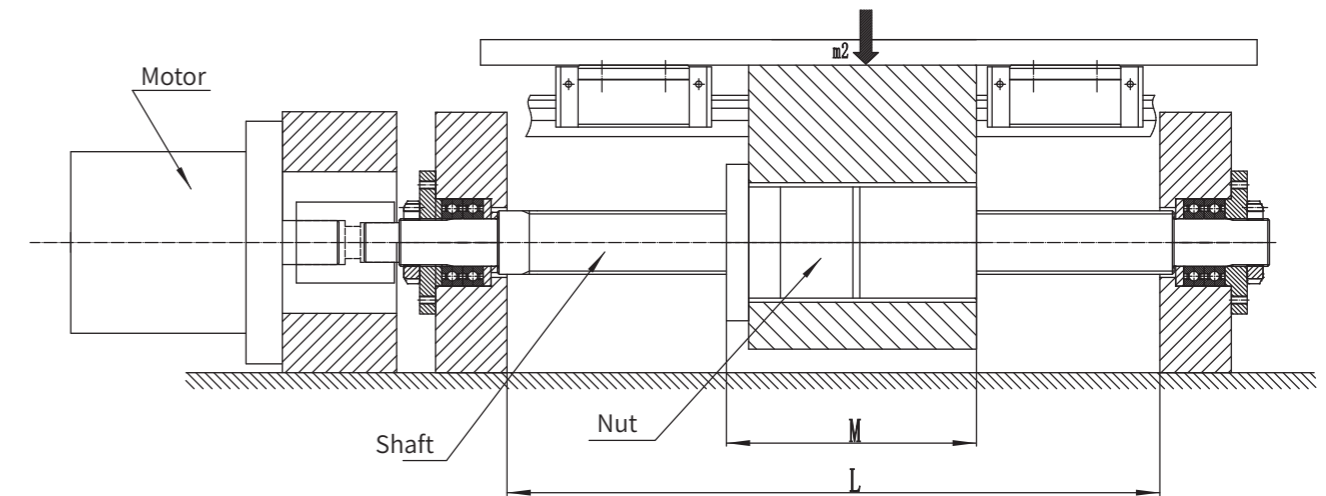

Figure 4.B.3

4-B-4 Slenderness ratio

The slenderness ratio of a ball screw is one of the key factors affecting its performance and equipment quality. The calculation formula: divide the distance between bearing contact surfaces by the screw's outer diameter. From the external appearance, when the screw's outer diameter is smaller while the length is longer, the screw will exhibit sagging in the middle section, indicating a higher slenderness ratio. Therefore, for equipment performance, this value should be as small as possible, as it enables the screw to withstand high-speed rotation without anomalies.

The slenderness ratio is also interrelated with the ball screw's precision grade, support bearing spacing, and outer diameter, collectively influencing the preload range.

Table 4.B.4 Permissible range of torque variation rate (Source: JISB1192)

Reference torque kgf×cm		Effective thread length (mm)										
		4000 below					4000 above - 10000 below					
		Slenderness ratio 1:40 below			Slenderness ratio 1:40 -1:60			-				
		Grade			Grade			Grade				
above	below	C1	C1	C2/C3	C5	C0	C1	C2/3	C5	C1	C2/C3	C5
2	4	±35%	±40%	±45%	±55%	±45%	±45%	±55%	±65%	-	-	-
4	6	±25%	±30%	±35%	±45%	±38%	±38%	±45%	±50%	-	-	-
6	10	±20%	±25%	±30%	±35%	±30%	±30%	±35%	±40%	-	±40%	±45%
10	25	±15%	±20%	±25%	±30%	±25%	±25%	±30%	±35%	-	±35%	±40%
25	63	±10%	±15%	±20%	±25%	±20%	±20%	±25%	±30%	-	±30%	±35%
63	100	-	-	±15%	±20%	-	-	±20%	±22%	-	±25%	±30%

- Notes: 1. The diameter-to-length ratio of the screw rod refers to the effective thread length divided by the outer diameter of the screw rod.
 2. Design the basic variation range of pre-tightening torque.
 3. For base torque values below 2kgf·cm, follow SHAC's alternative regulations

4-B-5 Pre-load range

The setting of the preload range for ball screws can be referenced to Table 1.3.8 by comparing the effective thread length diameter-length ratio e300 precision grade with the reference torque to determine the corresponding variation range, thereby avoiding the situation where a large diameter-length ratio with a low precision grade results in a small variation range of preload.

Calculation of reference torque

$$T_p = 0.05(\tan\beta)^{0.5} \times \frac{F_{ao} \times l}{2\pi}$$

F_{ao} = Preload (kgf)

l = Lead (cm)

β = Lead angle

Detection method:

As shown in Figure 1.3.4, while the lead screw rotates, an opposing force (F) is applied to the nut's lever arm to prevent the nut from rotating.

$$T_p = F \times L$$

F = Force (kgf)

L = Length of arm (cm)

Detection condition:

1. When detection without wiper.
2. Shaft rotate with 100rpm
3. Lubricating oil follow JSK2001\ISOVG68

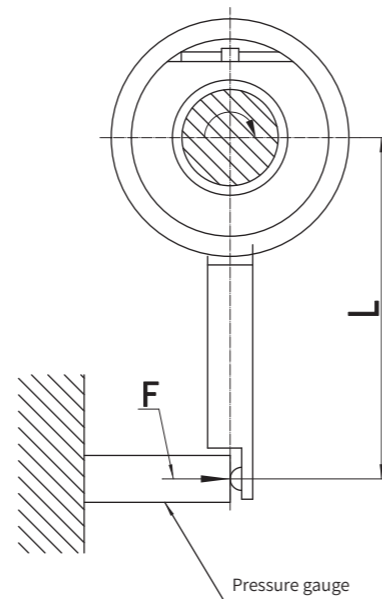

Figure 4.B.4

4-C Critical speed

When the ball screw rotates, the centrifugal force buckling caused by the self-weight sagging of the screw must be resisted by the bending strength of the shaft. When the rotational speed of the ball screw reaches the critical speed, the vibration deflection will increase unboundedly.

Therefore, from an engineering operation perspective, this phenomenon should be avoided.

$$N_c = 2.71 \times 10^8 \times \frac{M_f d_r}{L_t^2}$$

$$N_p = 0.8 N_c$$

N_c = critical speed (rpm)

Fixed-fixed

$M_f = 1$

N_p = maximum allowable speed (rpm)

Fixed-support

$M_f = 0.689$

d_r : screw shaft root diameter (mm)

Support-support

$M_f = 0.441$

L_t : support spacing (mm)

Fixed-free

$M_f = 0.157$

M_f : different assembly types

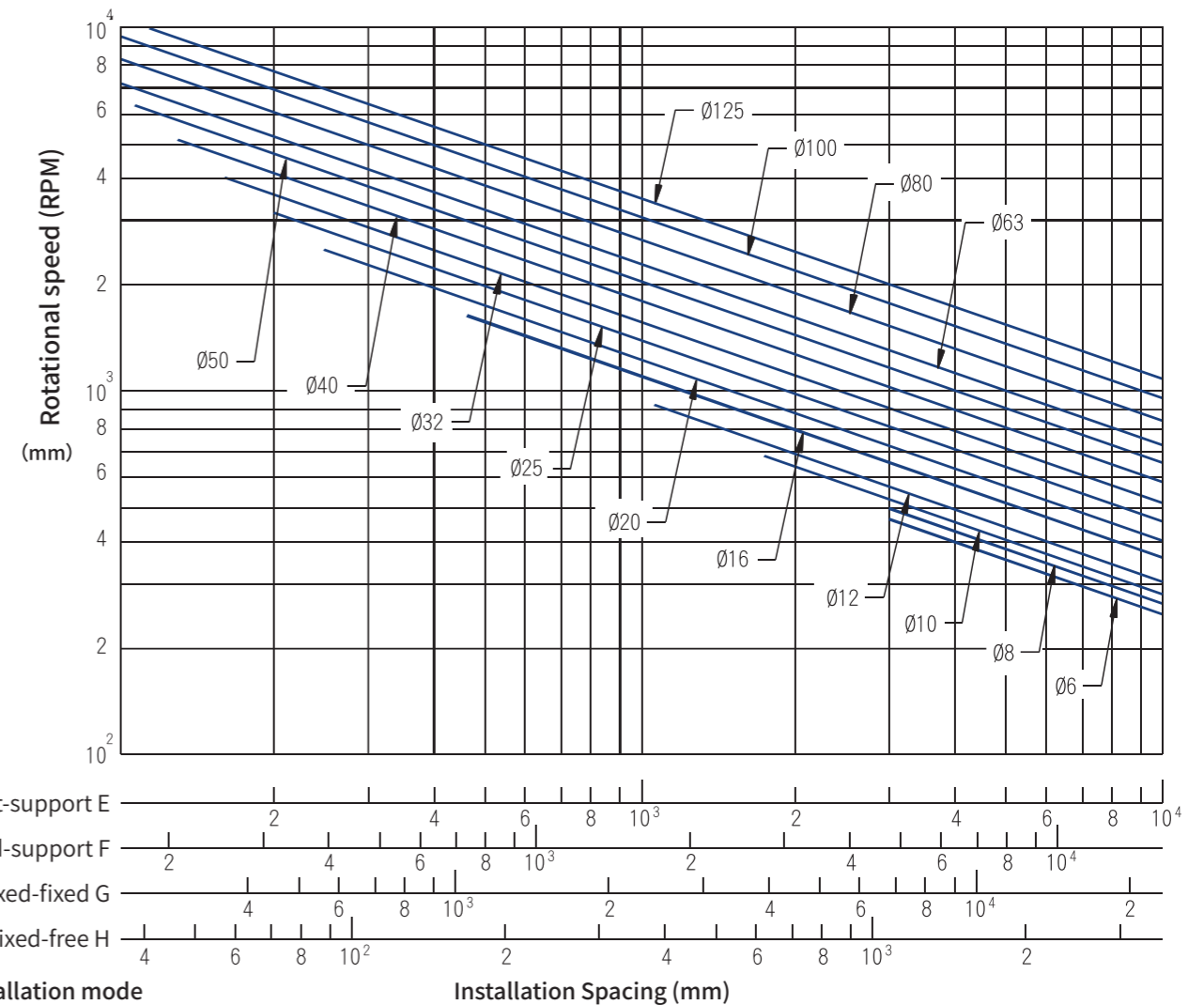

Fig 1.4.17 Max. Speed

By utilizing the lead screw fixing method and outer diameter dimensions, and consulting the critical speed data obtained from the cross-sections of the lines in this diagram based on the installation spacing, determine the suitability of the selection!

4-D Buckling load

The compressive load applied axially to the lead screw due to factors such as the workbench, work-piece, and self-weight can cause plastic deformation of the screw when the load reaches a certain level. This load is referred to as the buckling load, and appropriate shaft diameter and length should be selected to avoid it. Figure 1.4.16 shows the permissible compressive buckling load table.

$$P = \alpha \times \frac{I \times N \times \pi^2 \times E}{L^2} = m \frac{dr^4}{L^2} \times 10^3$$

P=Buckling Load(kgf)

a=Safety Factor(a=0.5)

I=Minimum second moment of area for the shaft cross-section of the lead screw

$$I = \frac{\pi}{64} dr^4 (\text{mm}^4)$$

E: (E=2.1×10⁴kgf/mm²)

dr=Root Diameter(mm)

L=Installation Spacing(mm)

m, N=Depending on the screw fixing method

Support-support m=5.1 (N=1)

Fixed-support m=10.2 (N=2)

Fixed-fixed m=20.3 (N=4)

Fixed-free m=1.3 (N=1/4)

1. The permissible tensile- compressive load P of the screw shaft's yield stress is given by

$P = \sigma A = 11.8 dr^2$ (kgf), where:

P: Buckling load (kgf)

σ : Permissible tensile- compressive stress (kgf/mm²)

A: Cross- sectional area of the screw thread root (mm²)

dr: Screw thread root diameter (mm)

2. Permissible load for the screw channel section:

The maximum axial load must be significantly less than the screw's basic static load rating.

When the installed length is relatively short, the fixing method has almost no effect on the beam compressive load. Please perform the verification according to the following two items.

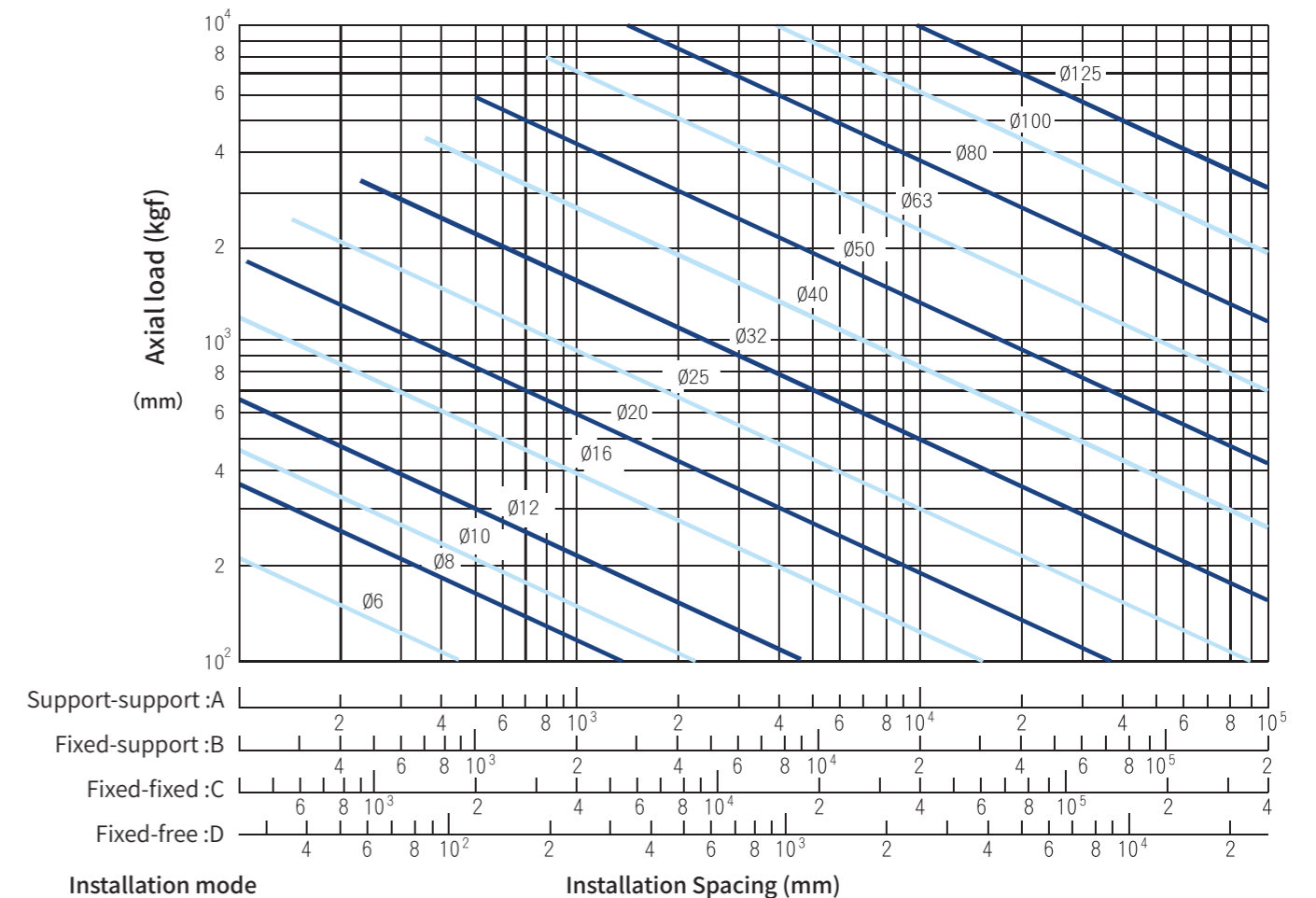

Figure 1.4.16 Permissible Compressive Load

By using the screw shaft fixing method and outer diameter dimensions, and by using the installation spacing to look up the axial load data at the intersection of the lines in this diagram, determine the suitability of the selection!

4-E Lead Accuracy

The various accuracies of the lead screw pitch directly affect the final accuracy of the equipment, so it is necessary to confirm and grasp its corresponding functions.

e300: It is often said that the ball screw is the heart of equipment. High precision of the screw does not necessarily guarantee high precision of the equipment, but low precision of the screw definitely results in low precision of the equipment. If you want the equipment precision to be within 0.01mm, you can basically choose an e300: 0.008 mm screw.

e2π: If the accuracy of the equipment needs to be controlled within the range of a single lead change, the range of a single lead variation needs to be considered.

± E: The cumulative lead variation over the full stroke directly affects the length of the screw thread, which has a significant impact on the accuracy control of CNC machine tools. Therefore, it is usually designed in the negative direction in CNC machine tool applications, thereby enhancing the control of temperature rise.

e: In the case of a longer operational range, besides controlling the length with the E value, if it is desired to maintain a certain range of accuracy variation, further control of the variation in lead over the full range of travel is required, to compress the range of dimensional changes within the operational range.

T-value: This is used to assist in confirming the direction and degree of cumulative lead change based on the $\pm E$ value. Typically, in the design of CNC machine tools, it represents the value of pre-tension. It helps ensure that the $\pm E$ value falls in the negative direction, and then reduces thermal deformation caused by the thermal expansion and contraction characteristics of the screw through pre-tensioning operation. Therefore, machine tools use the T-value to enhance control over stability and accuracy.

T+E: Due to the sensitivity of equipment accuracy to temperature changes, the ability to control the T+E value can also be regarded as the ability to control accuracy. Generally, this is achieved through 1-establishing a constant temperature workshop, 2-standardizing operation instructions, and 3-adjusting the T value on the screw drawing, thereby elevating equipment accuracy to a higher level.

4- F Nut cycle mode

4- F -1 Internal circulation nut

The cyclic structure of this nut's steel balls follow a three-dimensional S-shaped path, with several steel balls completing the path in a relatively short distance. Therefore, its impact resistance is limited, with a DN value of approximately 70,000. However, it has advantages in applications involving smaller outer diameters, smaller steel balls, and smaller lead screws. Under slow displacement conditions where space is limited, it is a more suitable choice than end-plug nuts.

4- F -2 End-plug nut

The circulating structure of this nut steel ball is achieved through the raceway in the back of the nut wall, which connects the reverser return circulation of the tangent paths on both ends of the nut. Coupled with the sound insulation and dust proof design on both ends of the nut during high-speed operation, the impact of high-speed steel balls is minimized, with a DN value of approximately 120,000. It is particularly suitable for high-speed, high-precision, light-load equipment requirements. If you have a design with a higher DN value, please consult SHAC.

4- F -3 External plugging circulating nut (new)

The circulating structure of this nut steel ball utilizes a reverser return pipe with an external plug-type tangent path for circulation. Coupled with sound insulation and dust proof design on both ends of the nut during high-speed operation, the impact of high-speed steel balls is minimized, with a DN value of approximately 130,000. It is particularly suitable for high-speed, high-precision, light-load equipment requirements. If you have a design with a higher DN value, please consult SHAC.

Hollow Cooling Ball Screw

H.1 Design Principles:

Core Transmission Mechanism (Traditional Ball Screw) Motion Conversion Principle Through the engagement of the screw and nut's helical grooves, the rolling action of internal circulating balls converts rotational motion into linear motion (or reverse conversion).

When the motor drives the screw to rotate, the balls roll along the helical grooves and push the nut to move axially, achieving efficient, and low-friction transmission.

Key Component Functions Screw and Nut: The helical groove structure guides ball circulation, creating rolling friction.

Balls: As rolling elements, they reduce sliding friction losses and enhance transmission efficiency.

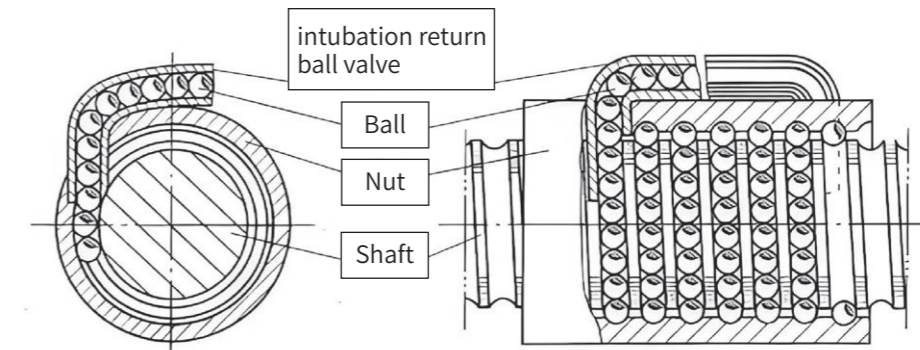

Fig 5.1.1 External return

H.2 Cooling System Function

Thermal Control Mechanism

Hollow structure ball screws are equipped with internal cooling channels.

These channels absorb heat generated during operation (e.g., frictional heat) through circulating cooling liquid (such as water or oil), to reduce the overall temperature of the screw.

This design effectively minimizes thermal deformation while maintaining transmission accuracy and stability.

Cooling Effect Advantages

Compared with the traditional solid structures, hollow water-cooled/forced-cooled technology can extend the service life of ball screw under high-load or long time operation conditions.

It also ensures optimal performance in high-speed and high-precision scenarios.

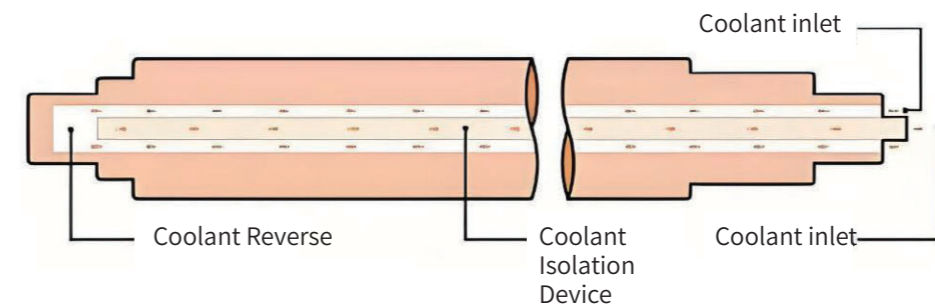

Figure 5.2.1

H.3 Summary

The hollow ball screw integrates rolling friction transmission with active heat dissipation technology.

It inherits the efficient and low-resistance motion characteristics of conventional ball screws while addressing the performance degradation caused by temperature rise through its internal cooling system, making it suitable for high-thermal-stability-demanding fields such as CNC machine tools and precision instruments.

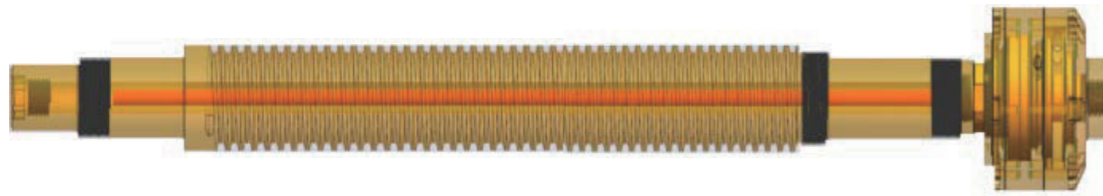

Figure 5.3.1

H.4 Performance:

Test Conditions:

1. When the rotational speed is the same, the temperature of the ball screw increases with the increase in axial load. For every 500 increment in axial load, the temperature of the solid ball screw increases by 5.4°C, while that of the hollow ball screw increases by 1.5°C. This indicates that the temperature change of the solid ball screw is more significantly affected by axial load.

The temperature difference between hollow and solid ball screw reveals that as the axial load increases, the temperature difference between hollow and solid ball screws becomes larger, demonstrating that the hollow ball screw is more suitable for heavy-duty loads.

2. When the axial load is constant, the temperature of the ball screw increases with rotational speed. For every 500 r/min increase in speed, the temperature of the solid ball screw rises by 2.3°C, while the hollow ball screw temperature increases by 1.3°C.

This shows that the solid ball screw temperature is more sensitive by speed changes.

Overall, the hollow ball screw is not only suitable for high-load and high-speed (high feed rate) operating conditions but also exhibits more stable temperature variations.

For machine tools, there is no need to worry about excessive temperature rise caused increasing axial load.

3. Through comparative analysis of heat dissipation between hollow and solid ball screws, it is observed that under the same axial load, their deformation is identical.

The introduction of cooling oil significantly reduces the radial thermal deformation of the hollow ball screw.

Compared with solid ball screws, the hollow ball screw minimizes the pre-tight force caused by thermal expansion between the ball screw and nut, preventing the vicious cycle of "temperature rise - increased thermal deformation - increased pre-tight force - temperature rise." In summary, the hollow ball screw with cooling oil outperforms the solid ball screw in high-speed and high-load scenarios.

Diagram

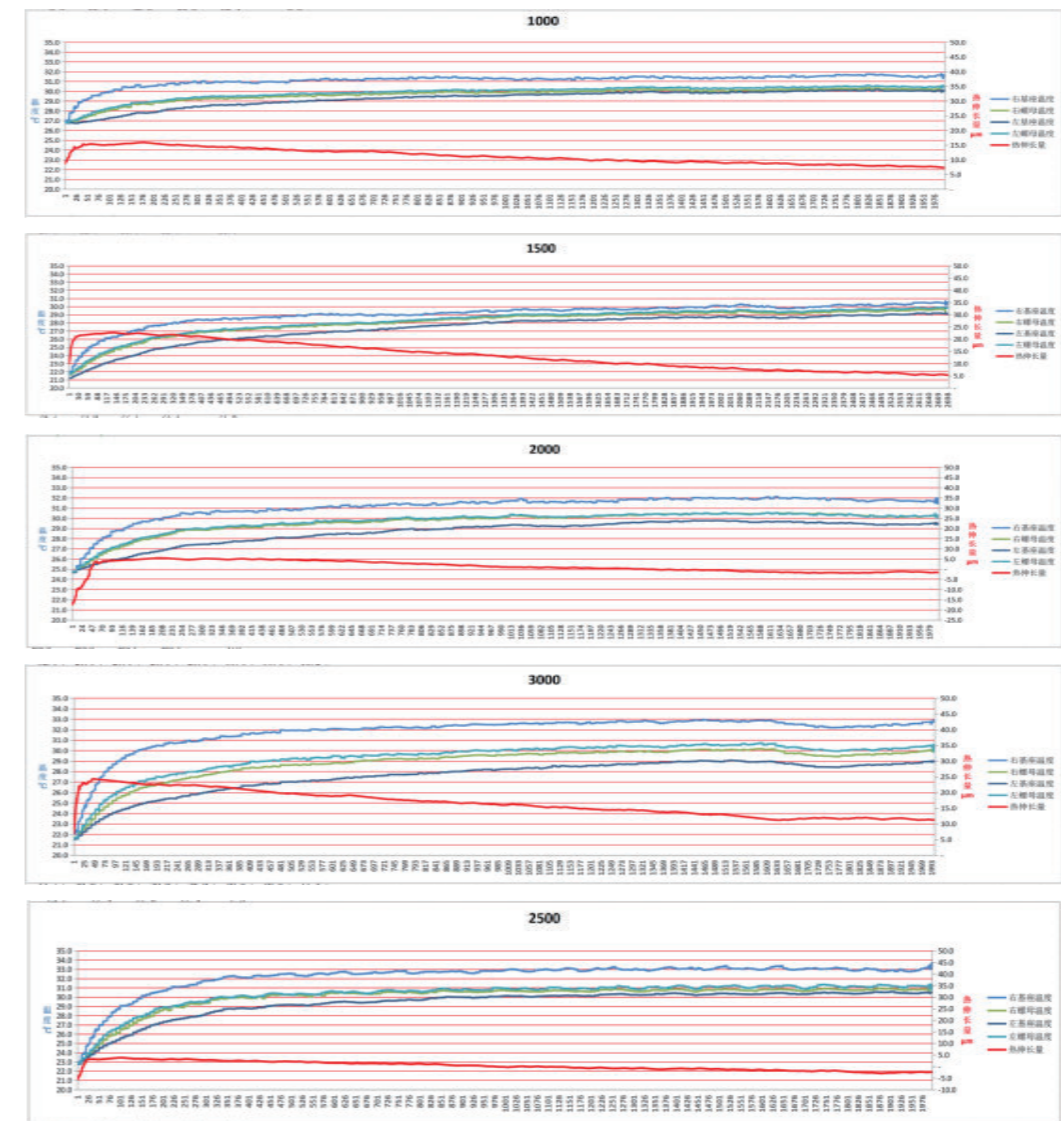
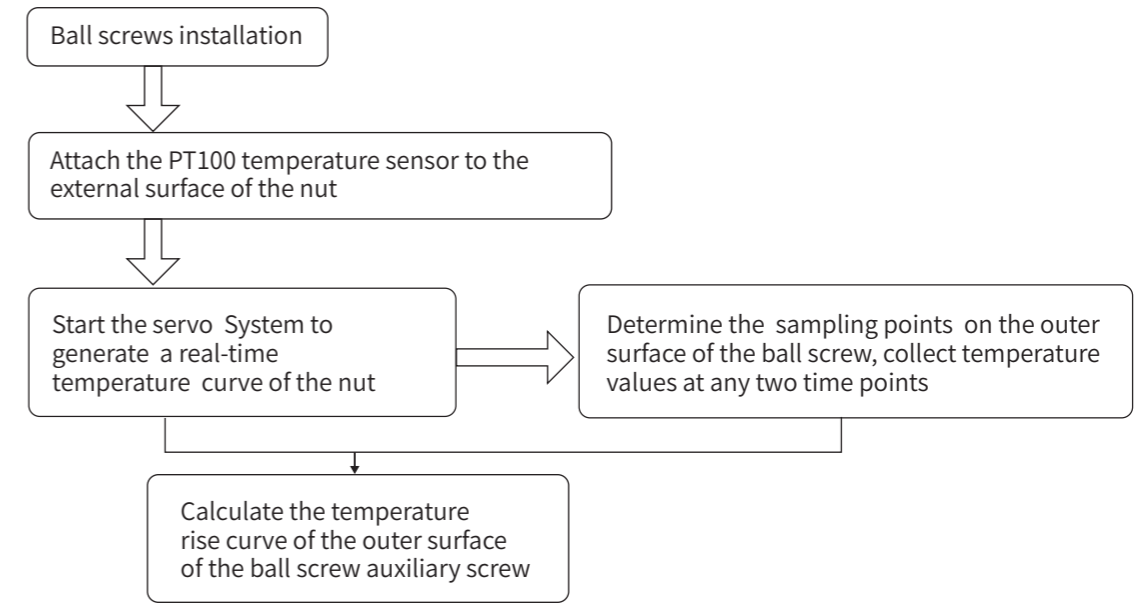
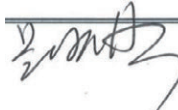

Figure H.4.1

H.5 Test and Inspection Report

ZHEJIANG JIANZHUANG TRANSMISSION TECHNOLOGY CO.,LTD 浙江健壯傳動科技有限公司		File No.	SJAC/BG.04003-2019					
Inspection&Testing Report		Date	2021-9-2					
		Version	A0	Page No.	1/1			
Test Dept.	R&D	Inspector	Yao Yujie					
Product Name	Ball screw	Model No.	YTR4010-A1-G1865.5-1573-C3					
Screw material	50CrMo4	Nut material	SM420H					
Inspection condetion								
Lab Add.	Ball screw performance testing laboratory	Lab.Equipment	Ball screw multiple performance testing machine					
Preload	P2	Accuracy	C3					
External load (N)	3,000 N	Ambient Temp.	22°C					
Lubrication medium	ISO L-HG (L-HG 68)	Refill method	Automatic oiling					
Refill interval	Every 10minutes, refill 5s	Movement distance	450mm					
Testing projects	Testing ball screw temperature rise curve and thermal elongation curve							
Inspection data								
Date	Nut	Screw	RPM	Achieve balanced running times	Max Thermal elongation	Equilibrium Temp.°C	Cooling medium and Temp.	Attached list
			r/min		mm			
2024.11.10	Standard	Standard	1000	1000	0.051	33-34		Standard-1000!A1
	Standard	Standard	1500	1300	0.065	37-39		Standard-1500!A1
	Standard	Standard	2000	1200	0.082	36-38		Standard2000-2!A1
	Standard	Standard	2500	1700	0.093	40-42		Standard-2500!A1
2025.2.7	Standard	Hollow liquid cooling	1000	1300	0.021	30-32	Water cooling 22°C	Water cooling-1000!A1
	Standard	Hollow liquid cooling	1500	1200	0.025	30-32	Water cooling 22°C	Water cooling-1500!A1
	Standard	Hollow liquid cooling	2000	1200	0.025	30-33	Water cooling 22°C	Water cooling-2000!A1
	Standard	Hollow liquid cooling	2500	1200	0.023	30-33	Water cooling 22°C	Water cooling-2500!A1
	Standard	Hollow liquid cooling	3000	1500	0.024	30-33	Water cooling 22°C	Water cooling-3000!A1
Experimental Comments	Normal type screw maximum elongation and its equilibrium temperature are positively correlated with the rotational speed; The maximum elongation and equilibrium temperature of the hollow liquid cooled screw have no significant changes with the increase in rotational speed,and remain stable within a certain range. The maximum elongation and its constant temperature of hollow liquid cooled screw are much lower than normal screw							

Recorder: 

Auditor: 

Inspection seal: 

H.6 Application

Hollow ball screw are suitable for high-precision machine tools.

They can work well with high-speed operation of conveying mechanisms, especially when high-precision positioning is required.

Since motion generates heat causing thermal expansion and contraction, the heat makes the ball screw expansion.

To prevent this change, hollow ball screw were developed.

The hollow design of the ball screw shaft blocks heat conduction, achieving cooling effects.

Moreover, the hollow shaft and standardized processing at both ends of the screw shaft effectively reduce thermal expansion.



H.7 Features:

The four advantages of hollow shaft ball screw:

1. Stable positioning accuracy: The hollow shaft design effectively suppresses thermal expansion, maintaining the stability of the ball screw's positioning accuracy.
2. Prevent displacement: By reducing thermal expansion, the hollow shaft keeps the displacement of the ball screw support shaft and base within the minimum range, avoiding thermal deformation in the work-table.
3. Shorten preheating time: The cooling effect of the hollow shaft rapidly reduces temperature rise, thereby shortening the equipment's preheating time.
4. Maintain lubrication performance: Preventing heat generation in the ball screw slows down the degradation of lubrication oil, ensuring its effectiveness.
5. DINGHAN exclusively develop hollow shaft ball screw special connector which eliminates leakage issues during general use.

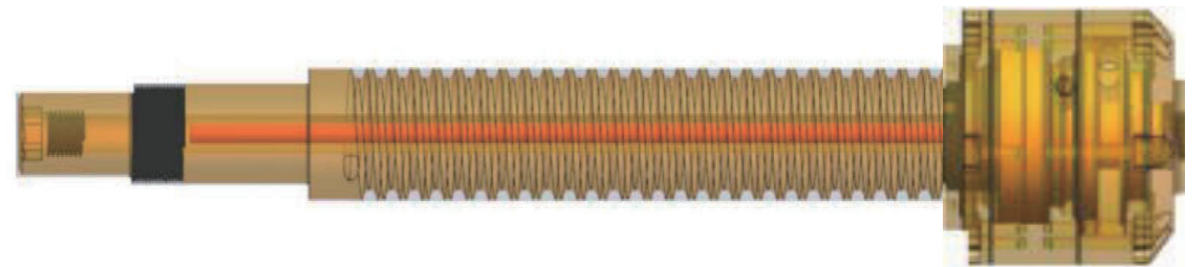

H.8 Technical Specifications: Three Advantages of Hollow Ball Screw:

1. In conventional ball screws, direct friction between the screw and balls generates heat, causing thermal deformation and affecting transmission accuracy.

Under conditions where transmission force and speed are not significant and precision requirements are not strict, ordinary ball screws are generally used due to their lower cost.

However, for special cases requiring high transmission force/speed and precision, hollow oil-cooled ball screws are recommended.

2. Hollow ball screws utilize oil or water circulation to cool the screw body, effectively preventing overheating and maintaining stable temperature control to ensure precision.

3. Hollow ball screws offer advantages of reduced self-weight and increased surface area, minimizing excessive sagging from self-weight and lowering motor driving torque through reduced moment of inertia.

Additionally, the hollow section allows coolant flow to dissipate heat, achieving superior temperature control.

H.9 Specifications and Model:

YTR4010-A1-G1865.5-1573-C3 (Hollow threaded rod)

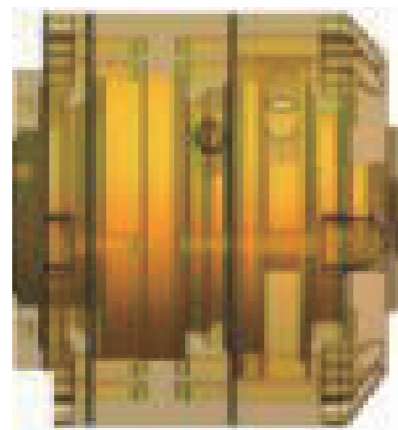
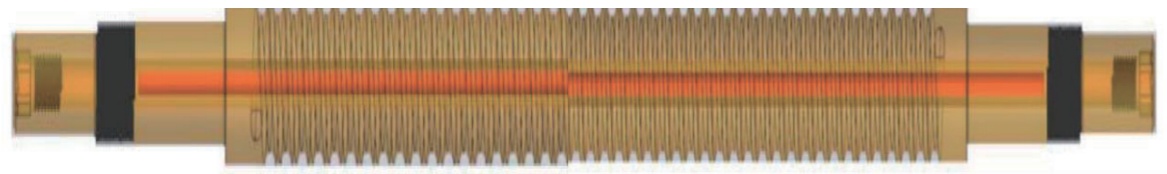

5 SHAC Ball Screw Product Series

5-1 Nominal Model Code of SHAC Ball Screw

Hollow ball screw are suitable for high-precision machine tools.

They can work well with high-speed operation of conveying mechanisms, especially when high-precision positioning is required.

Since motion generates heat causing thermal expansion and contraction, the heat makes the ball screw expansion.

To prevent this change, hollow ball screw were developed.

The hollow design of the ball screw shaft blocks heat conduction, achieving cooling effects.

Moreover, the hollow shaft and standardized processing at both ends of the screw shaft effectively reduce thermal expansion.

Table 5-1-1 Ball Screw : SFNUR-025-05T4-DT-PA-G-C5-600P1-SS

Code	Feature	1	2	34	5	678	9/10	11/12	13	14	15/16	17	18/19	20/21/22/23	24/25	26/27	28/29	30/31	
Rolled	Ground	S	F	NU	R	025	05	T4	D	T	PA	G	C5	600	P1	B2	N3	N3	
P.C.D.	S: Single D: Double				Threading Direction R:Right L:Left	Nominal Diameter Unit: mm	Lead Unit: mm	Number of Turns (Turn/ Row) T:1, A:1.8, B:2.8, C:3.8, D:4.8 ex: (2.8x2 =B2)	Flange Type N: Not Cutting S: Single Cutting D: Double Cutting M: Multiple Cutting	Dust proof Type K: Hexa Gonal Clamp Spring D: Maze Type G: End Cap T: One Piece Type TPE	Material PA: Plastic Reverser FE: Metal Reverser Y: Plastic Circular Reverser	Production Process G: Ground F: Rolled	Accuracy Grade CO, C1, C2, C3, C5, C7, C10	Total Length of Shaft Unit: mm	Preload PO, P1, P2, P3, P4	Number of Nut (Leave blank if only one nut is required) Ex:install two nuts on a shaft B2	Nut Surface Treatment S: Standard B1: Black Oxidation N1: Hard Chrome Plating P: Phosphating N3: Nickel Plating	Shaft Surface Treatment S: Standard B1: Black Oxidation N1: Hard Chrome Plating P: Phosphating N3: Nickel Plating	
120,000	E: E-type nut/end plug external circulation/double-headed Y: Y-type nut/end plug external circulation/double-headed DC: Multi-piece end plug (single/double head) A,S: S-type nut/end plug external circulation/single head	Nut Remarks:			Type A nuts and shaft Outer diameter above 12 mm are combination type circulators.														
70,000	NI: NI type nut \ internal circulation NU: NU type nut \ U DIN internal circulation K: K-type nut/insert type/ internal circulation X: Customer specific (add X after the third code)	The purpose of the combination circulator is to overcome the problem of the screw rod not coming out at both ends.			DC The cyclic device of the type nut is also a combination type, designed for those who cannot exit the tail														
DN Value																			
120,000	SFBH,DFB,SFB Heavy load type External circulation SFU electric cylinder dedicated	D			DC nut U type nut I type nut	T	One Piece Type TPE	A,Y type nut NU type nut NI type nut	G	End cap	S type nut	K	Hexagonal Clamp Spring	E type nut	Remarks: When the surface treatment is applied to both the lead screw and nut				

5-1-2 Shaft Specification:

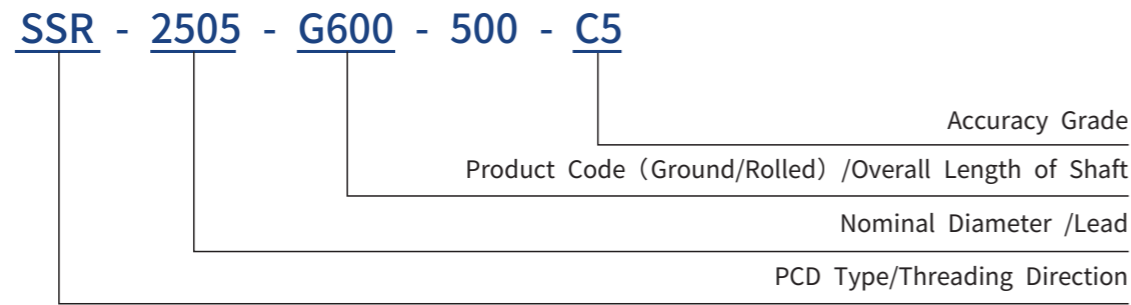

5-1-3 Nut Specifications:

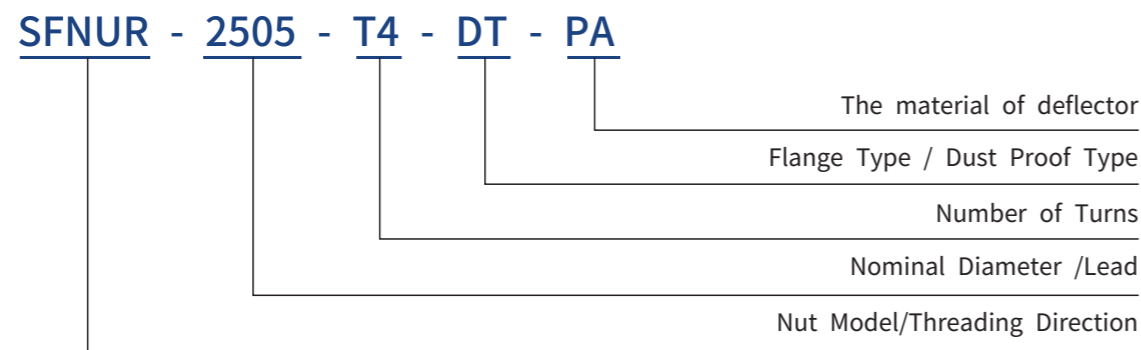

5-2 Rolled Ball Screw

Rolling ball screw is a type of screw that uses two thread forming rollers. Through advanced German machine tools and SHAC extrusion technology on circular smooth rods, it produces a Gothic shaped profile screw with low friction and smooth operation, and is supplied quickly and at a good price.

SHAC adopts standardized material selection, rolling process, heat treatment, processing and assembly operation procedures, and strictly controls the quality of rolled lead screws to ensure the best consistency of products. If there is a need for pre tightening force, the elimination of axial clearance can also be fully met.

SHAC rolling screw specifications are fully equipped with a sufficient number of standard inventory parts annually to meet urgent needs and make it easier to exchange screw nuts. The nut type and size are the same as those of grinding grade screws, please refer to the selection.

According to the international standard (ISO), the reference for the lead accuracy of rolling ball screws is as follows: the allowable cumulative lead error for any 300mm within the effective screw length of each grade is C7=0.052mm and C10=0.21mm.

Table 5.2.1 Permissible Values for Variation in Thread Length of 300mm (e300) and Wobble (e2π) (JIS B1192)

Accuracy Class		C5	C7	C10
ISO, DIN	e300	23	52	210
JIS		18	50	210
SHAC		18	50	210
	e2π	8		
Processing Technology		Rotary Milling/Rolling Screw		

SHAC[®] provides C5 grade rotary milling ball screws, produced using high-precision whirlwind milling machines from Germany, providing users with a new option for applications that do not require grinding grade high precision and consider insufficient rolling accuracy.

SHAC[®] sets the specifications for preload and axial clearance to facilitate users in selecting suitable rolling ball screws.

The purpose of applying pressure is to eliminate the axial backlash of the ball screw and increase rigidity. The Gothic raceway design with a 45 degree contact angle has a unique channel structure that can easily eliminate backlash and increase rigidity. Appropriate preload can improve both accuracy and rigidity. Excessive preload can have a certain impact on service life due to temperature rise effects, while insufficient preload can cause step loss. Therefore, the appropriate preload should be selected according to the model and purpose.

Table 5.2.2 Classification of Axial Play

Grade	P0	P1	P2	P3	P4
Axial Play	Yes	a	No	No	No
Preload	No	b	Light	Medium	Heavy
Ca%	0	3 below	3~5%	5~7%	7~9%

Table 5.2.3 Selection reference table

Grade	Suggest Preload	Suggested Nut Form	Suggested Lead Screw Form
C10	P0 (Table 5.2.5)	Single nut	Rolling screw rod
C7	P1a (with axial play \ 50% axial play of P0) P1b (with Preload \ 3% below of Ca) The SHAC ® standard is (P1)	According to customer needs	Rolling or grinding screw
C5	Produce according to Customer requirements, if not specified The SHAC ® standard is (P2)	According to customer needs	Rolling or grinding screw (with lead check list attached)
C3	Produce according to customer requirement, otherwise SHAC assistance do calculate.	According to customer needs	Grinding lead screw (with lead check list attached)

SHAC® suggests that the maximum preload should not exceed 10% of the dynamic load, as the screw will have a better service life and lower temperature rise effect. Generally, light preload refers to less than 3%, light to medium preload refers to 3% to 5%, medium preload refers to 5% to 7%, and medium to heavy preload refers to 7% to 9%.

Table 5.2.4 P2 Preload Spring Force Reference Table

Model	Spring Force (Kg) Single Nut		Spring Force (Kg) Double Nut	
	1605	0.1~0.3	±50	±35
2005	0.1~0.3	±50	±35	0.3~0.6
2505	0.2~0.5	±40	±35	0.3~0.6
3205	0.2~0.5	±40	±25	0.5~0.8
4005	0.2~0.5	±40	±25	0.5~0.8
2510	0.2~0.5	±40	±25	0.5~0.8
3210	0.3~0.6	±35	±25	0.5~0.8
4010	0.3~0.6	±35	±25	0.5~0.8
5010	0.3~0.6	±35	±20	0.8~1.2
6310	0.6~1.0	±25	±20	0.8~1.2
8010	0.6~1.0	±25	±20	0.8~1.2

Table 5.2.5 Axial Play (PO) Clearance in the Axial Direction of Rolled and Ground Ball Screw Unit: mm

Nominal Diameter	Rolled Ball Screw Clearance In the Axial Direction(mm)	Ground Ball Screw Clearance in the Axial Direction(mm)
φ04-φ14	0.05	0.015
φ15-φ40	0.08	0.025
φ50-φ100	0.12	0.05

Note:

a) For ball screw with preloading requirements, if the customer does not specify the preloading range, the P2 preloading in Table 1.3.6 will be followed and the spring force range will be further set based on the slenderness ratio, accuracy level, and reference torque.

b) P1 micro gap is 50% of P0 (if there is a gap, there is no preload, or if there is preload, there is no gap!)

Note: For ball screw with clearance requirements, if the customer does not specify the axial clearance size, it will be executed according to Tables 1.3. 7.

5-2-1 Rolled Screw Shaft Standard Specifications

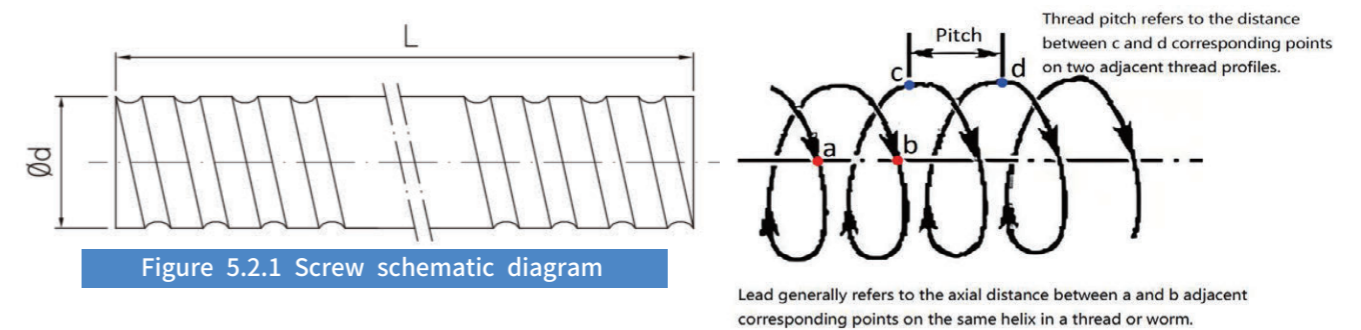

Figure 5.2.1 Screw schematic diagram

Table 5.2.6 Rolled and Stock Screw Standard Row Dimension Specification Comparison Unit: mm

Model No.			Lead accurat grade	Thread direction Left \ Right	Numbwe of grooves	Standard Code of Shaft	Type of Nut	Max. Length of Shaft
O.D.φd	Lead	Ball Dia.						
12	10	2.5	C10、C7、C5	R	2	SSR01210	S	3000
16	5	2.778	C10、C7、C5	R/L	1	SSR01605	S、H	1000
	10	2.778	C10、C7、C5	R	2	SSR01610	S、H	
	16	2.778	C10、C7、C5	R	4	SSR01616	S、H	
	20	2.778	C10、C7、C5	R	4	SSR01620	S	
20	10	3.175	C10、C7、C5	R	2	SSR02010	S、H	3000
25	10	3.175	C10、C7、C5	R/L	2	SSR02510	S、H	6000
	25	3.175	C10、C7	R	4	SSR02525	S、H	
32	10	3.969	C10、C7、C5	R	1	SSR03210	S、H	6000
	20	3.969	C10、C7	R	2	SSR03220	S、H	
	32	3.969	C10、C7	R	4	SSR03232	S	
40	10	6.35	C10、C7	R	1	SSR04010	S、H	6000
	20	6.35	C10、C7、C5	R	2	SSR04020	S	
	40	6.35	C10、C7	R	4	SSR04040	S	
50	10	6.35	C10、C7	R	1	SSR05010	S、H	6000
	20	6.35	C10、C7	R	2	SSR05020	S	
	50	6.35	C10、C7	R	4	SSR05050	S	

*The above are standard specifications. For C5 and other requirements, please consult SHAC sales staff.

Table 5.2.7 Standard Size Specifications Comparison Table 40-80

Unit: mm

Model No.			Lead accuract grade	Thread direction	Numbwe of grooves	Standard Code of Shaft	Type of Nut	Max. Length of Shaft
O.D.φd	Lead	Ball Dia.		Left \ Right				
6	1	0.8	C10、C7	R	1	SCR00601	K	1000
8	1	0.8	C10、C7、C5	R	1	SCR00801	K	1000
	2	1.2	C10、C7、C5	R	1	SCR00802	K	
	2.5	1.2	C10、C7、C5	R	1	SCR0082.5	K、BSH	
10	2	1.2	C10、C7、C5	R	1	SCR01002	K、BSH	3000
	4	2	C10、C7、C5	R	1	SCR01004	K、BSH	
12	2	1.2	C10、C7、C5	R	1	SCR01202	K	3000
	4	2.5	C10、C7、C5	R	1	SCR01204	U、BsH	
	5	2.5	C10、C7、C5	R/L	1	SCR01205-A	V、U、BSH、S、H	
	5	2.5	C10、C7、C5	R	1	SCR01205-B	K	
	10	2.5	C10、C7、C5	R	2	SCR01210-B	V	
14	2	1.2	C10、C7、C5	R	1	SCR01402	K	1800
	4	2.5	C10、C7	R	1	SCR01404	BSH	3000
16	4	2.381	C10、C7、C5	R	1	SCR01604	V、I、U、BSH	3000
	5	3.175	C10、C7、C5	R/L	1	SCR01605	V、I、U、BSH	
	10	3.175	C10、C7、C5	R	2	SCR01610	V、I、U、BSH	
	16	2.778	C10、C7、C5	R	4	SCR01616	Y	
	32	2.778	C10、C7	R	8	SCR01632	Y	
20	4	2.381	C10、C7、C5	R	1	SCR02004	V、I、U	3000
	5	3.175	C10、C7、C5	R/L	1	SCR02005	V、U、BSH、S、H	
	20	3.175	C10、C7、C5	R	4	SCR02020	V、Y、S、H	
	40	3.175	C10、C7	R	8	SCR02040	Y	
25	4	2.381	C10、C7	R	1	SCR02504	I、U	6000
	5	3.175	C10、C7、C5	R/L	1	SCR02505	V、U、BsH、S、H	
	10	4.762	C10、C7、C5	R	1	SCR02510—A	I、U、BsH	
	10	6.35	C10、C7、C5	R	1	SCR02510—B	V	
	25	3.969	C10、C7、C5	R	4	SCR02525	V、Y	
	50	3.969	C10、C7	R	8	SCR02550	Y	
32	4	2.381	C10、C7、C5	R	1	SCR03204	V、I、U	6000
	5	3.175	C10、C7、C5	R/L	1	SCR03205	V、I、U、a、S、H	
	10	6.35	C10、C7、C5	R/L	1	SCR03210	V、I、U	
	32	4.762	C10、C7	R	4	SCR03232	Y	
	64	4.762	C10、C7	R	8	SCR03264	Y	

*The above are standard specifications. For C5 and other requirements, please consult SHAC sales staff.

Table 5.2.8 S-Type Dimension Specification Comparison (φ12-50 mm)

Unit: mm

Model No.			Lead accuract grade	Thread direction	Numbwe of grooves	Standard Code of Shaft	Type of Nut	Max. Length of Shaft
O.D.φd	Lead	Ball Dia.		Left \ Right				
40	5	3.175	C10、C7、C5	R	1	SCR04005	V、I、U、S、H	6000
	10	6.35	C10、C7	R	1	SCR04010	V、I、U	
	20	6.35	C10、C7	R	2	SCR04020	V	
	40	6.35	C10、C7	R	4	SCR04040	Y	
	80	6.35	C10、C7	R	8	SCR04080	Y	
50	5	3.175	C10、C7、C5	R	1	SCR05005	V、S、H	6000
	10	6.35	C10、C7、C5	R/L	1	SCR05010	Y、I、U	
	20	9.525	C10、C7	R	1	SCR05020	V	
	50	7.938	C10、C7	R	4	SCR05050	Y	
	100	7.938	C10、C7	R	8	SCR050100	Y	
63	10	6.35	C10、C7、C5	R	1	SCR06310	V、I、U	7000
	20	9.525	C10、C7	R	1	SCR06320	V、U	
80	10	6.35	C10、C7、C5	R	1	SCR08010	V、I、U	7000
	20	9.525	C10、C7	R	1	SCR08020	V、U	

5-3 Ground Ball Screw Standard Specifications

Table 5.3.1 Standard Length of Ground Ball Screw

Unit: mm

Nominal Diameter	Lead																	Maximum length of Shaft	Thread length Peeling Ballscrew			
	1	1.5	2	2.5	4	5	6	8	10	12	14	16	20	25	30	32	40			50	64	80
6	●																				120	
8	●	●	■	●		●															160	
10			●		●	●				●											200	
12			●		■	■				■			■								250	2000
14			●																		300	
16					●	■				■			●	●							800	5500
20					●	■	●	●	●				●	●				●			1000	5500
25					●	■	●	●	■	●			●	●	●			●			1500	5500
28							●	●	●	●			●								2000	5500
32					■	■	●	●		●			●	●			●		●		2500	5500
36							●		●	●			●	●							2500	5500
40					■	■	●	●		●			●	●				●		●	3000	5500
45										●											3000	5500
50						●	●	●		●			●	●		●	●				3000	5500+
55										●											3000	5500+
63										●	●		●	●				●			3000	6300+
80										●	●		●	●	●						3000	6300+
100													●	●	●						3000	

■ Left-hand threaded screw available

● Only right-hand lead screws are produced +Connectable thread

5-3-1 Nut Code















Product Image	Code	Page	Product Image	Code	Page
	Heavy SFBH	P262		OFNU	P277
	Heavy DFB SFB	P263		OFNI	P278
	Heavy DFDC SFDC	P264 P268		DFS SFS	P279 P280
	Heavy DFNU SFNU	P272 P273		DFNI SFNI	P282 P283
	Heavy SFU Special for electric	P274		SFA	P284
	Heavy SFKH Special for electric	P2756		SFK	P286
	SFY	P276		SMA	P287

Figure 5-3-1

5-4 Grinding Ball Screw Standard Model No. Series

Size Table of SFBH Ball Screw (Heavy-duty Tubular Type)

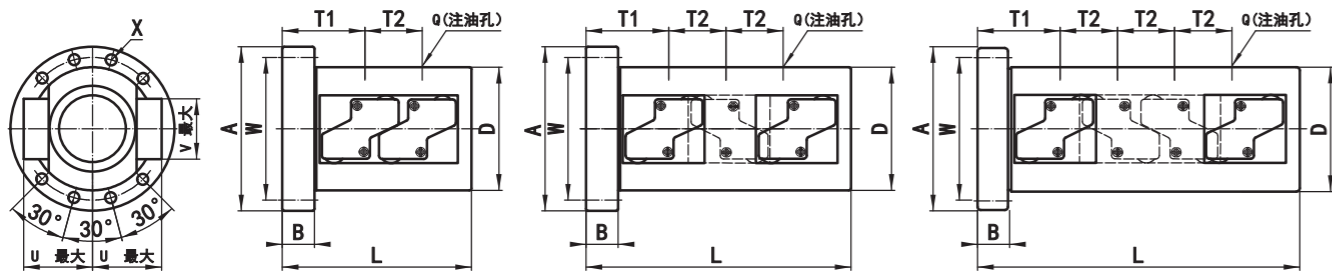

Model no.	d	l	Da	dr	n	Load Rating Ca (kgf)	Load Rating Co (kgf)	Dimension										Bend Protrusion	
								Q	T1	T2	L	A	B	Φ	W	D	V	U	
SFBHR5014-7.5	50	14	9.525	42.25	2.5*3	22015	70623	3-PT1/8	66.5	42	202	114	28	8-Φ9	97	80	39	54.5	
SFBHR5016-7.5		16	12.7	40	2.5*3	31645	93696	3-PT1/8	80	48	226	129	28	8-Φ9	112	95	45	64	
SFBHR6316-5	63	16	12.7	53	2.5*2	25224	78535	2-PT1/8	80	48	164	139	28	8-Φ9	122	105	47	70	
SFBHR6316-7.5					2.5*3	35748	117803	3-PT1/8			228								
SFBHR6320-5		20	15.875	50.24	2.5*2	33362	97641	2-PT1/8	96.5	60	199	157	32	8-Φ11	137	117	56.5	78	
SFBHR6320-7.5					2.5*3	47281	146461	3-PT1/8			279								
SFBHR8016-7		80	16	12.7	70	3.5*2	36785	135509	2-PT1/8	83	64	200	154	32	8-Φ9	137	120	60	80
SFBHR8016-10.5	3.5*3					52132	203263	3-PT1/8	278										
SFBHR8016-14	3.5*4					66766	271017	4-PT1/8	342										
SFBHR8020-7	20		15.875	67.24	3.5*2	48943	166706	2-PT1/8	96.5	80	239	170	32	8-Φ11	150	130	66	82	
SFBHR8020-10.5					3.5*3	69364	250059	3-PT1/8			339								
SFBHR8025-5	25		19.05	64.49	2.5*2	46197	141328	2-PT1/8	85.75	75	232	185	40	8-Φ11	165	145	69	93	
SFBHR8025-7.5					2.5*3	65472	211991	3-PT1/8			332								
SFBHR10020-10.5	100		20	15.875	87.24	3.5*3	77935	317549	3-PT1/8	97	80	339	185	32	8-Φ11	165	145	78	96
SFBHR10020-14						3.5*4	99811	423399	4-PT1/8			419							
SFBHR10025-10.5			25	19.05	84.49	3.5*3	99783	383666	3-PT1/8	117.75	100	422	199	40	8-Φ11	179	159	71	108
SFBHR10025-14		3.5*4				127792	511554	4-PT1/8	522										
SFBHR12020-7.5	120	20	15.875	107.24	2.5*3	65381	283691	3-PT1/8	105	60	287	213	40	8-Φ11	193	173	60	108	
SFBHR12020-10					2.5*4	83734	378255	4-PT1/8			347								
SFBHR12025-10.5		25	19.05	104.49	3.5*3	108216	457149	3-PT1/8	117.75	100	421	213	40	8-Φ11	193	173	71	116	
SFBHR12025-14					3.5*4	138592	609533	4-PT1/8			521								

The stiffness values shown in the table represent spring constants. Each constant is obtained from the load and elastic deformation when 30% of the axial basic rated dynamic load (Ca) is applied in the axial direction.

This value does not include the rigidity values of the nut mounting part and related components. Therefore, please take 80% of the values in the table as the approximate evaluation criterion. When the actual axial load (Fa0) is not 0.3Ca, the rigidity value (Kn) can be calculated by the following formula.

$$K_N = K \left(\frac{Fa_0}{0.3Ca} \right)^{\frac{1}{3}}$$

K: The rigid values in the size table

If you need to make different turns in the above table, please consult SHAC.

Size Table of SFB/DFB Ball Screw

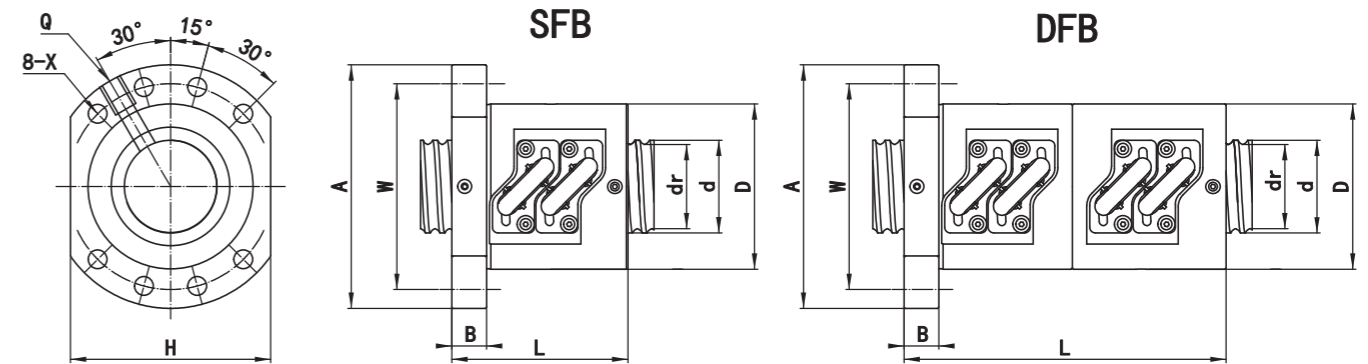

Model no.	d	l	Da	dr	Load Rating Ca(kgf)	Load Rating Co(kgf)	K kgf/μm	Dimension									
								D	A	B	L	W	H	X	Q	n	
SFBR3205-5	32	5	3.175	29.35	2579	8885	75	57	84	12	63	71	69	6-Φ6.6	M6*1	2.5*2	
SFBR4005-5	40	5	3.175	37.35	2829	11191	87	65	95	12	63	80	75	8-Φ9	M8*1	2.5*2	
SFBR4006-5	40	6	3.969	36.64	3857	13885	91	65	95	16	73	80	75	6-Φ9	M8*1	2.5*2	
SFBR5008-5	50	8	4.762	46.12	5403	20641	112	83	121	18	92	103	92	8-Φ11	M8*1	2.5*2	

Model no.	d	l	Da	dr	Load Rating Ca(kgf)	Load Rating Co(kgf)	K kgf/μm	Dimension									
								D	A	B	L	W	H	X	Q	n	
DFBR3205-5	32	5	3.175	29.35	2579	8885	116	57	84	12	111	71	69	6-Φ6.6	M6*1	2.5*2	
DFBR4005-5	40	5	3.175	37.35	2829	11191	135	65	95	12	111	80	75	8-Φ9	M8*1	2.5*2	
DFBR4006-5	40	6	3.969	36.64	3857	13885	141	65	95	16	134.5	80	75	6-Φ9	M8*1	2.5*2	
DFBR5008-5	50	8	4.762	46.12	5403	20641	173	83	121	18	161	103	92	8-Φ11	M8*1	2.5*2	

1. The values marked with "*" in the table can be used for left-hand lead screws, with nut dimensions identical to those of right-hand lead screws.

2. The stiffness values shown in the table represent spring constants. Each constant is determined by applying a preload of 30% of the axial basic rated dynamic load (Ca) and then applying an axial load equal to three times the preload, with both the load and elastic deformation taken into account.

This value does not include the stiffness values of the nut mounting section and related components. Therefore, please consider 80% of the values in the table as a rough guideline.

If the actual preload (Fa0) is not 0.1Ca, the stiffness value (Kn) can be calculated using the following formula.

$$K_N = K \left(\frac{Fa_0}{0.3Ca} \right)^{\frac{1}{3}}$$

If you need to produce different numbers of coils from the table above, please consult SHAC.

K: The rigid values in the size table

Size Table of DFDC Ball Screw

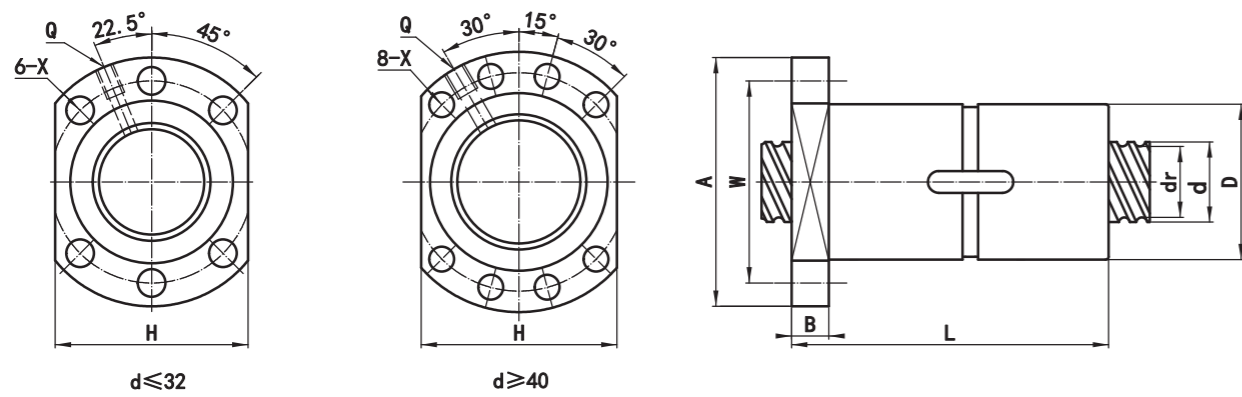

Model no.	d	l	Da	dr	Load Rating Ca(kgf)	Load Rating Co(kgf)	K kgf/μm	Dimension																	
								D	A	B	L	W	H	X	Q	n									
DFDCR1610-3.8	16	10	3.969	12.64	1729	3558	55	34	56	12	122	45	43	6-Φ6.6	M6*1	3.8*1									
DFDCR2006-3.8	20	6	3.175	17.35	1821	4640	72	36	58	12	87	47	44	6-Φ6.6	M6*1	3.8*1									
DFDCR2008-3.8		8	3.969	16.64	1975	4510	61	38	60	12	106	49	46	6-Φ6.6	M6*1	3.8*1									
DFDCR2010-3.8		10			122	49	46																		
DFDCR2506-3.8	25	6	3.175	22.35	2027	5879	67	40	62	12	92	51	48	6-Φ6.6	M6*1	3.8*1									
DFDCR2508-3.8		8			1652	4645	68				105	51	48												
DFDCR2510-3.8		10	3.969	21.64	2216	5722	71	43	65	15	127	54	51	6-Φ6.6	M6*1	3.8*1									
DFDCR2512-3.8	12	2206			5704	72	140																		
DFDCR2516-3.8	16	4.762	21.12	2179	5663	70	45	65	15	180	54	51	6-Φ6.6	M6*1	3.8*1										
DFDCR2508-3.8	8			2847	6941	75				111.5															
DFDCR2510-3.8	10			2837	6923	75				127															
DFDCR2512-3.8	12	4.762	21.12	2825	6901	75	45	65	15	147	54	51	6-Φ6.6	M6*1	3.8*1										
DFDCR2516-3.8	16			2795	6845	75				180															
DFDCR2520-3.8	20	4.762	21.12	2758	6774	73	46	68	16	206	57	52	6-Φ6.6	M8*1	4.8*1										
DFDCR2806-4.8	6			3.969	24.64	2926				8416						97	46	68	16	107.5	57	52	6-Φ6.6	M8*1	4.8*1
DFDCR2808-4.8	8			4.762	24.12	3691				9884						101	48	74	12	126.5	60	60	6-Φ6.6	M6*1	4.8*1
DFDCR2810-4.8	10	3680	9863			101	146.5																		
DFDCR2812-4.8	12	4.762	24.12	3668	9837	102	48	74	12	170.5	60	60	6-Φ6.6	M6*1	4.8*1										
DFDCR2816-B1	16			2288	5701	60				143						2.8*1									
DFDCR2812-4.8	12	6.35	22.90	5189	12584	108	54	87	16	173.5	72	69	6-Φ9	M8*1	4.8*1										

Size Table of DFDC Ball Screw-2

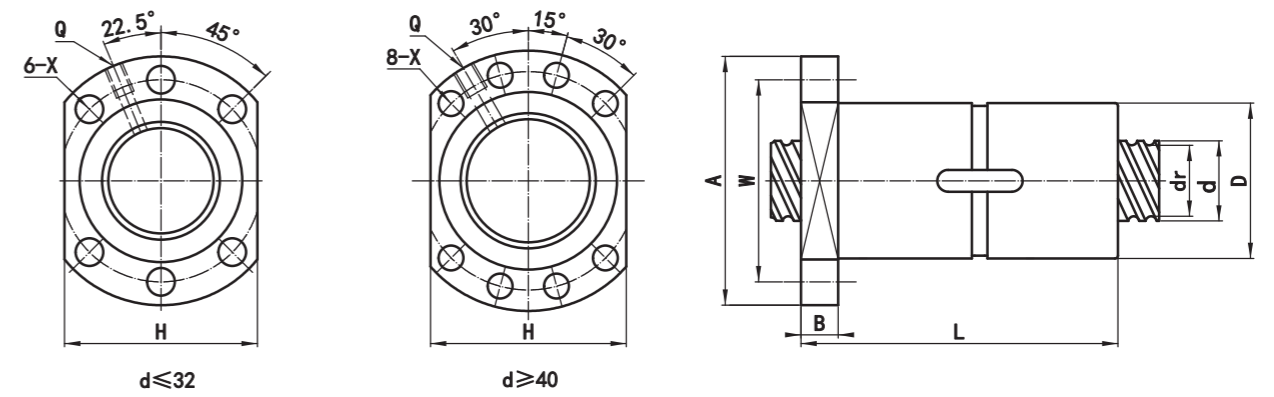

Model no.	d	l	Da	dr	Load Rating Ca(kgf)	Load Rating Co(kgf)	K kgf/μm	Dimension									
								D	A	B	L	W	H	X	Q	n	
DFDCR3204-4.8	32	4	2.381	29.96	1500	5674	91	48	72	12	80	60	54	6-Φ6.6	M6*1	4.8*1	
DFDCR3205-3.8		5	3.175	29.35	1849	6028	79	50	87	16	81.5	72	69	6-Φ9	M8*1	3.8*1	
DFDCR3206-4.8		6	3.969	28.64	3016	9208	101	50	80	16	107.5	65	62	6-Φ9	M8*1	4.8*1	
DFDCR3208-4.8	8	3011			9195	103	126.5										
DFDCR3210-4.8	10	4.762	28.12	3084	9547	108	53	87	16	146.5	72	69	6-Φ9	M8*1	4.8*1		
DFDCR3212-4.8	12			3075	9527	109				170.5							
DFDCR3216-4.8	16			3055	9478	108				210.5							
DFDCR3208-4.8	36	8	6.35	26.90	3858	11021	107	57	87	16	127	76	68	6-Φ9	M8*1	4.8*1	
DFDCR3210-4.8		10			3850	11002	108				147						
DFDCR3212-4.8		12	3840	10980	108	172.5											
DFDCR3216-3.8	16	6.35	26.90	3218	9060	90	57	87	16	178.5	72	69	6-Φ9	M8*1	3.8*1		
DFDCR3220-3.8	20			3191	9001	89				206.5							
DFDCR3210-4.8	40	10	6.35	26.90	5624	14592	116	56	80	12	155	68	62	6-Φ6.6	M8*1	4.8*1	
DFDCR3212-4.8		12			5609	14563	116				173						
DFDCR3216-3.8		16	5573	14490	116	181.5	3.8*1										
DFDCR3606-4.8	36	6	3.969	32.64	3237	10743	113	54	87	16	107.5	72	69	8-Φ9	M8*1	4.8*1	
DFDCR3610-4.8		10	4.762	32.12	4116	12663	119	57	87	16	147	72	68	8-Φ9	M8*1	4.8*1	
DFDCR3610-4.8		10	6.35	30.90	6011	16617	125	61	91	18	148.5	76	68	6-Φ9	M8*1	4.8*1	
DFDCR3612-4.8	12	5998			16591	125	172.5										
DFDCR3616-4.8	16	5967	16524	126	212.5												
DFDCR3620-3.8	20	6.35	30.90	4849	13015	101	61	91	18	208.5	76	68	6-Φ9	M8*1	3.8*1		
DFDCR4004-4.8	4			2.381	37.96	1037				3027						62	56
DFDCR4005-4.8	5	3.175	37.35	2478	9592	112	58	91	18	97	76	68	8-Φ9	M8*1	4.8*1		

Size Table of DFDC Ball Screw-3

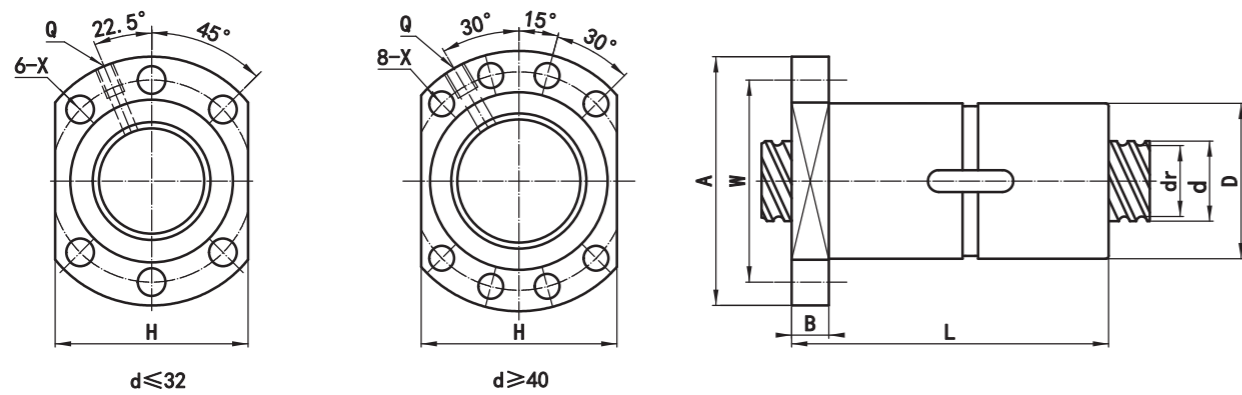

Model no.	d	l	Da	dr	Load Rating Ca(kgf)	Load Rating Co(kgf)	K kgf/μm	Dimension									
								D	A	B	L	W	H	X	Q	n	
DFDCR4006-4.8	40	6	3.969	36.64	3378	11901	118	58	91	18	108.5	76	68	6-Φ9	M8*1	4.8*1	
DFDCR4008-4.8		8	4.762	36.12	4361	14340	126	60	91	18	132.5	76	68	8-Φ9	M8*1	4.8*1	
DFDCR4010-4.8		10			153.5												
DFDCR4010-4.8		10	6.35	34.90	6343	18597	135	66	95	18	157.5	80	72	8-Φ9	M8*1	4.8*1	
DFDCR4012-4.8		12			173.5												
DFDCR4016-4.8		16			212.5												
DFDCR4010-4.8		10			7.144	34.18	7453				21026						141
DFDCR4012-4.8		12	174														
DFDCR4016-4.8		16	214.5														
DFDCR4020-4.8		20	262														
DFDCR4512-4.8		45	12	7.144	39.18	7839	23526	153	80	115	18	173	98	90	8-Φ9	M8*1	4.8*1
DFDCR5008-4.8			8	4.762	46.12	4732	17692	143	70	105	18	127.5	88	80	8-Φ11	M8*1	4.8*1
DFDCR5010-4.8	10		6.35	44.90	7053	23544	156	75				118					
DFDCR5012-4.8	12				173.5												
DFDCR5016-4.8	16				213.5												
DFDCR5010-4.8	10				7.144	44.18	8206		26069	160	80		118	18	157	100	92
DFDCR5012-4.8	12		182														
DFDCR5016-4.8	16		214.5														
DFDCR5020-4.8	20		263														
DFDCR5030-3.8	50		30	7.938	43.37	9317	28650	170	82	120	20	301	102	94	8-Φ11	M8*1	3.8*1
DFDCR5040-3.8			40			393											
DFDCR5012-4.8			12	9.525	42.25	12155	35153	177	89	134	25	185.5	114	100	8-Φ14	M8*1	4.8*1
DFDCR5016-4.8		16	226.5														
DFDCR5020-4.8		20	266.5														
DFDCR5020-4.8		20	12.7			40.00	17391	46472				206					
DFDCR5512-4.8		55	12	7.144	49.18	8524	28565	173	90	128	18	173	110	100	8-Φ11	M8*1	4.8*1

Size Table of DFDC Ball Screw-4

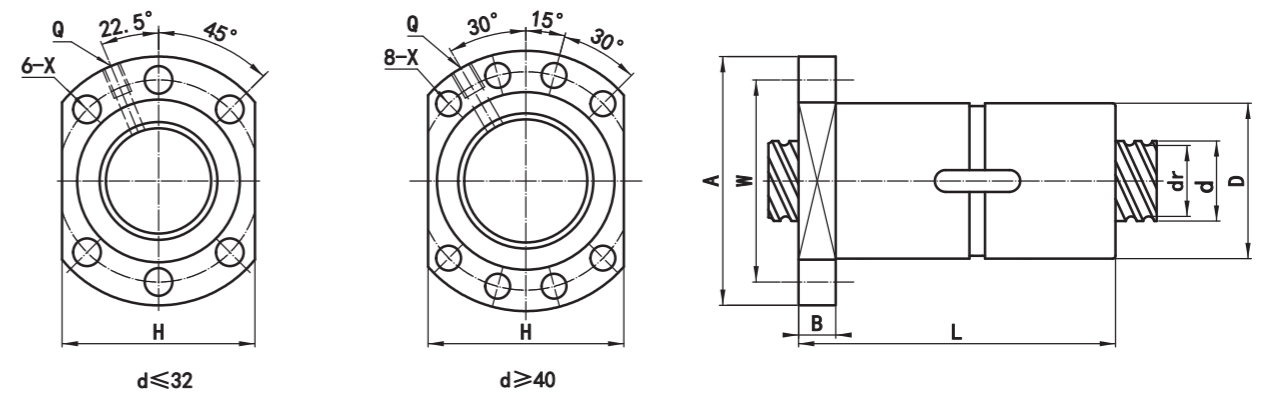

Model no.	d	l	Da	dr	Load Rating Ca(kgf)	Load Rating Co(kgf)	K kgf/μm	Dimension									
								D	A	B	L	W	H	X	Q	n	
DFDCR6310-4.8	63	10	6.35	57.90	7725	29495	178	88	135	20	155.5	115	100	8-Φ11	M8*1	4.8*1	
DFDCR6310-4.8		10	7.144	57.18	9179	33564	186	93	131	20	155.5	113	100	8-Φ11	M8*1	4.8*1	
DFDCR6312-4.8		12	7.938	56.37	10534	36804	192	95	135	20	182.5	115	100	8-Φ11	M8*1	4.8*1	
DFDCR6316-4.8		16			225.5												
DFDCR6316-4.8		16	9.525	55.25	13477	44049	205	102	147	25	228	127	112	8-Φ14	M8*1	4.8*1	
DFDCR6320-4.8		20			266.5												
DFDCR6340-3.8		40			396.5	3.8*1											
DFDCR6316-4.8		16			12.7		53.00				19712						58580
DFDCR6320-4.8		20	285														
DFDCR8010-4.8		80	10	6.35	74.90	8623	38372	206	105	152	20	155.5	132	122	8-Φ11	M8*1	4.8*1
DFDCR8012-4.8			12	7.938	73.37	11758	47607	210	110	157	20	181.5	137	120	8-Φ11	M8*1	4.8*1
DFDCR8016-4.8			16	9.525	72.25	15190	57374	242	118	165	25	228	145	130	8-Φ14	M8*1	4.8*1
DFDCR8020-4.8	20		265														
DFDCR8016-4.8	16		12.7	70.00	22107	74477	255	132	176	28	245	154	145	8-Φ14	M8*1	4.8*1	
DFDCR8030-4.8	30				394												
DFDCR10030-3.8	100		30	9.525	92.25	13428	55863	234	145	192	25	328	172	158	8-Φ14	M8*1	3.8*1
DFDCR10040-3.8			40			403											
DFDCR10020-4.8			20	12.7	90.00	24549	94184	300	150	194	28	287	172	160	8-Φ14	M8*1	4.8*1

Note: A star symbol can be used to make a left-hand screw.

- The values marked with "*" in the table can be used for left-hand lead screws, with nut dimensions identical to those of right-hand lead screws.
- The stiffness values shown in the table represent spring constants. Each constant is determined by applying a preload of 10% of the axial basic rated dynamic load (Ca) and then applying an axial load equal to three times the preload, with both the load and elastic deformation taken into account.

This value does not include the stiffness values of the nut mounting section and related components. Therefore, please consider 80% of the values in the table as a rough guideline. If the actual preload (Fa0) is not 0.1Ca, the stiffness value (Kn) can be calculated using the following formula.

$$K_N = K \left(\frac{Fa_0}{0.3Ca} \right)^3$$

K: The rigid values in the size table

If you need to produce different numbers of coils from the table above, please consult SHAC.

Size Table of SFDC Ball Screw

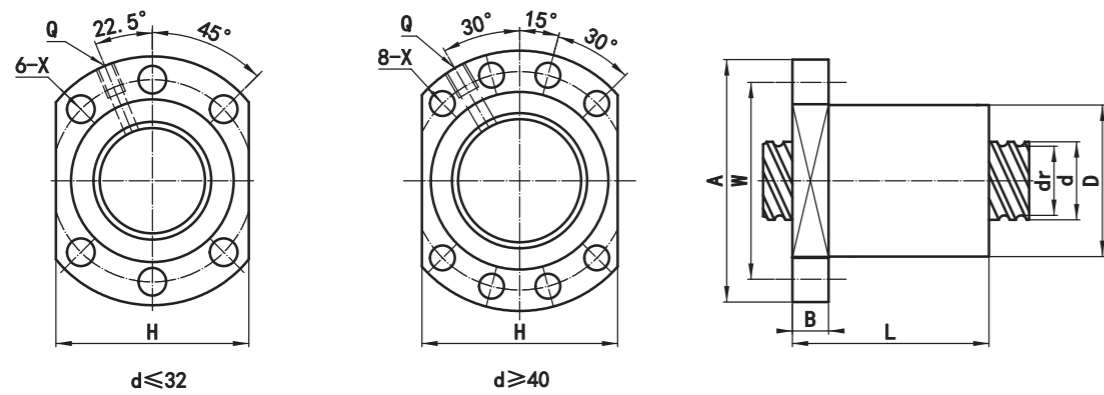

Model no.	d	l	Da	dr	Load Rating Ca(kgf)	Load Rating Co(kgf)	K kgf/μm	Dimension								
								D	A	B	L	W	H	X	Q	n
SFDCR1610-3.8	16	10	3.969	12.64	1729	3558	35	34	56	12	62	45	43	6-Φ6.6	M6*1	3.8*1
SFDCR2006-3.8	20	6	3.175	17.35	1821	4640	46	36	58	12	51	47	44	6-Φ6.6	M6*1	3.8*1
SFDCR2008-3.8		8	3.969	16.64	1975	4510	39	38	60	12	54	49	46	6-Φ6.6	M6*1	3.8*1
SFDCR2010-3.8	10	1964			4491	39	62									
SFDCR2506-3.8	25	6	3.175	22.35	2027	5879	43	40	62	12	56	51	48	6-Φ6.6	M6*1	3.8*1
SFDCR2508-3.8		8			1652	4645	44				57					
SFDCR2510-3.8	25	10	3.969	21.64	2216	5722	46	43	65	15	67	54	51	6-Φ6.6	M6*1	3.8*1
SFDCR2512-3.8		12			2206	5704	46				74					
SFDCR2516-3.8	25	16	3.969	21.64	2179	5663	45	43	65	15	92	54	51	6-Φ6.6	M6*1	3.8*1
SFDCR2508-3.8		8			2847	6941	48				59.5					
SFDCR2510-3.8	25	10	3.175	22.35	2837	6923	48	40	62	12	67	51	48	6-Φ6.6	M6*1	3.8*1
SFDCR2512-3.8		12			2825	6901	48				75					
SFDCR2516-3.8	25	16	3.969	21.64	2795	6845	48	43	65	15	92	54	51	6-Φ6.6	M6*1	3.8*1
SFDCR2520-3.8		20			2758	6774	47				106					
SFDCR2806-4.8	28	6	3.969	24.64	2926	8416	63	46	68	16	56.5	57	52	6-Φ6.6	M8*1	4.8*1
SFDCR2808-4.8		8	3691	9884	65	48	74	12	60	60	6-Φ6.6	M6*1	4.8*1			
SFDCR2810-4.8	10	3680	9863	65	76.5											
SFDCR2812-4.8	28	12	4.762	24.12	3668	9837	66	48	74	12	86.5	60	60	6-Φ6.6	M6*1	4.8*1
SFDCR2816-1.8		16			2288	5701	39				74.5					
SFDCR2812-4.8	28	12	6.35	22.90	5189	12584	70	54	87	16	89.5	72	69	6-Φ9	M8*1	4.8*1
SFDCR3204-4.8		32	4	2.381	29.96	943	3310	59	48	72	12	34	60	54	6-Φ6.6	M6*1
SFDCR3205-3.8	5		3.175	29.35	1849	6028	51	50	87	16	44	72	69	6-Φ9	M8*1	3.8*1

Size Table of SFDC Ball Screw-2

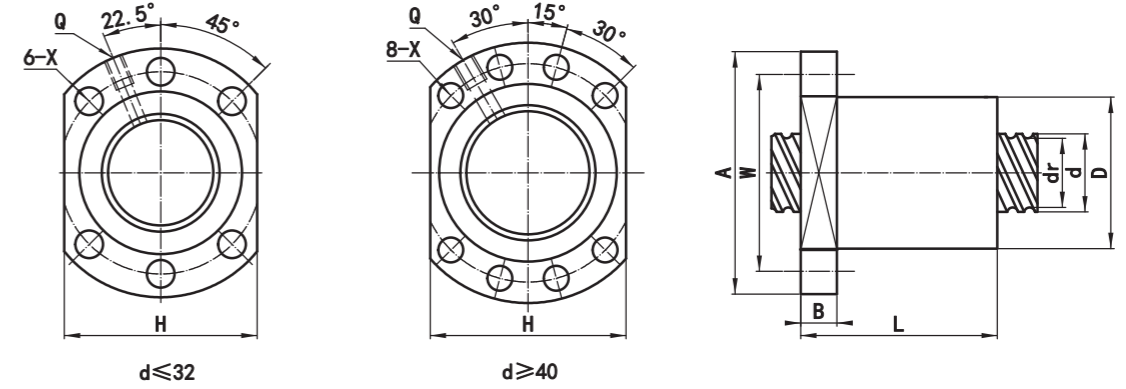

Model no.	d	l	Da	dr	Load Rating Ca(kgf)	Load Rating Co(kgf)	K kgf/μm	Dimension													
								D	A	B	L	W	H	X	Q	n					
SFDCR3206-4.8	32	6	3.969	28.64	3016	9208	65	50	80	16	56.5	65	62	6-Φ9	M8*1	4.8*1					
SFDCR3208-4.8		8			66.5																
SFDCR3210-4.8		10			76.5																
SFDCR3212-4.8		12			86.5																
SFDCR3216-4.8		16			106.5																
SFDCR3208-4.8	32	8	4.762	28.12	3858	11021	69	53	87	16	67	72	69	6-Φ9	M8*1	4.8*1					
SFDCR3210-4.8		10			77																
SFDCR3212-4.8		12			88.5																
SFDCR3216-3.8		16			90.5																
SFDCR3220-3.8		20			106.5																
SFDCR3210-4.8	32	10	6.35	26.90	5624	14592	75	57	87	16	80	72	69	6-Φ9	M8*1	4.8*1					
SFDCR3212-4.8		12			89																
SFDCR3216-3.8		16			109.5																
SFDCR3216-3.8	36	16	6.35	30.90	5573	14490	75	61	91	18	109.5	76	68	6-Φ9	M8*1	4.8*1					
SFDCR3606-4.8		6			3237	10743	73				56.5						72	69	8-Φ9	M8*1	4.8*1
SFDCR3610-4.8		10			4116	12663	77				77						72	68	8-Φ9	M8*1	4.8*1
SFDCR3610-4.8		10			6011	16617	81				78.5						76	68	6-Φ9	M8*1	4.8*1
SFDCR3612-4.8		12			5998	16591	81														
SFDCR3616-4.8	16	5967	16524	81	108.5	76	68	6-Φ9	M8*1	4.8*1											
SFDCR3620-3.8	20	4849	13015	65	108.5						3.8*1										
SFDCR4004-4.8	40	4	2.381	37.96	1037	3027	40	56	80	12	34	68	62	6-Φ6.6	M8*1	4.8*1					
SFDCR4005-4.8		5	3.175	37.35	2478	9592	72	58	91	18	53	76	68	8-Φ9	M8*1	4.8*1					
SFDCR4006-4.8		6	3.969	36.64	3378	11901	76	58	91	18	57	76	68	6-Φ9	M8*1	4.8*1					
SFDCR4008-4.8		8	4.762	36.12	4361	14340	81	60	91	18	68.5	76	68	8-Φ9	M8*1	4.8*1					
SFDCR4010-4.8		10			4355	14325	83				78.5										
SFDCR4010-4.8		40	10	6.35	34.90	6343	18597	87	66	95	18	82.5	80	72	8-Φ9	M8*1	4.8*1				
SFDCR4010-4.8	10		6343			18597	87	82.5				80						72	8-Φ9	M8*1	4.8*1

Size Table of SFDC Ball Screw-3

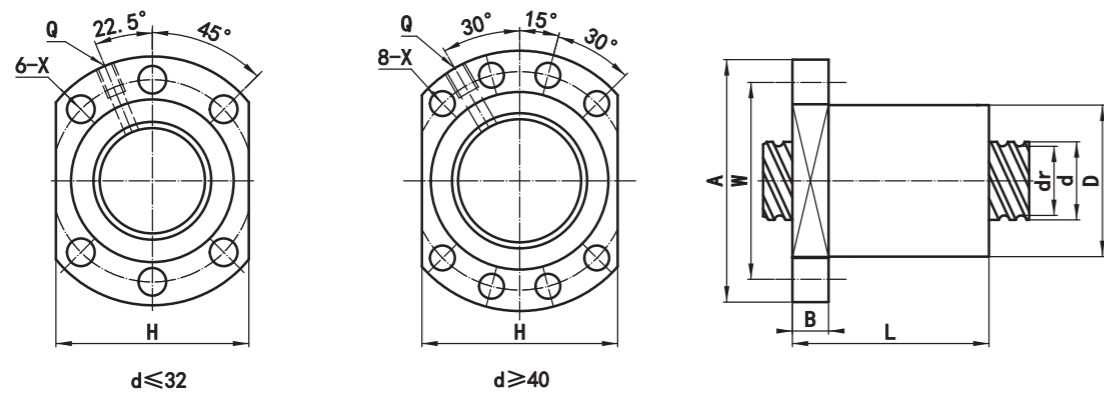

Model no.	d	l	Da	dr	Load Rating Ca(kgf)	Load Rating Co(kgf)	K kgf/μm	Dimension								
								D	A	B	L	W	H	X	Q	n
SFDCR4012-4.8	40	12	7.144	34.18	6332	18573	88	70	105	18	89.5	88	80	8-Φ11	M8*1	4.8*1
SFDCR4016-4.8		16			6305	18512	88				108.5					
SFDCR4010-4.8		10			7453	21026	91				82					
SFDCR4012-4.8		12			7441	20999	92				90					
SFDCR4016-4.8		16			7409	20931	92				110.5					
SFDCR4020-4.8		20			7370	20844	93				132					
SFDCR4512-4.8		45			12	7.144	39.18				7839					
SFDCR5008-4.8	50	8	4.762	46.12	4732	17692	92	70	105	18	67.5	88	80	8-Φ11	M8*1	4.8*1
SFDCR5010-4.8		10	6.35	44.90	7053	23544	101	75	118	18	82.5	100	92	8-Φ11	M8*1	4.8*1
SFDCR5012-4.8		12			7045	23524	102				89.5					
SFDCR5016-4.8		16			7026	23474	104				109.5					
SFDCR5010-4.8		10	7.144	44.18	8206	26069	103	80	118	18	82	100	92	8-Φ11	M8*1	4.8*1
SFDCR5012-4.8		12			8197	26047	105				92					
SFDCR5016-4.8		16			8175	25992	106				110.5					
SFDCR5020-4.8		20			8146	25922	106				133					
SFDCR5030-3.8		30			7.938	43.37	9317				28650					
SFDCR5040-3.8		40	9163	28286			108	193								
SFDCR5012-4.8	12	9.525	42.25	12155	35153	114	89	134	25	95.5	114	100	8-Φ14	M8*1	4.8*1	
SFDCR5016-4.8	16			12122	35079	116				114.5						
SFDCR5020-4.8	20			12080	34986	117				136.5						
SFDCR5020-4.8	20			12.7	40.00	17391				46472						133
SFDCR5512-4.8	55	12	7.144	49.18	8524	28565	112	90	128	18	89	110	100	8-Φ11	M8*1	4.8*1

Size Table of SFDC Ball Screw-4

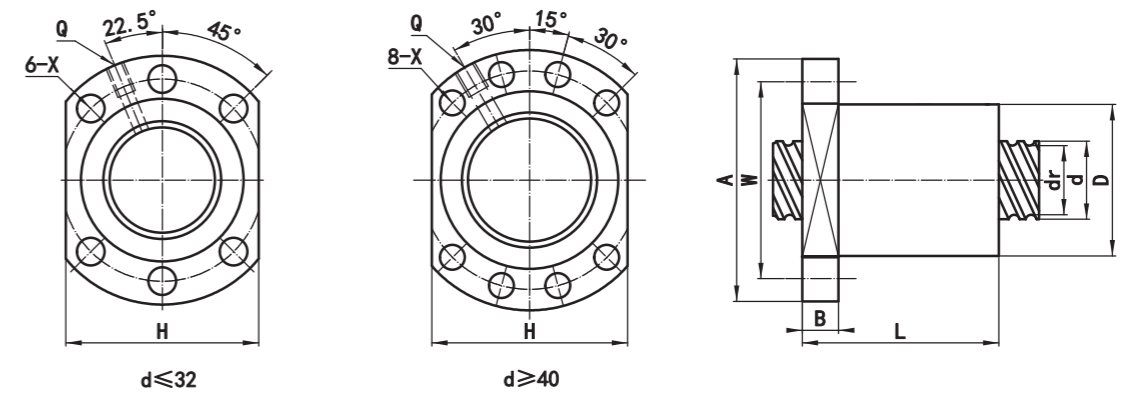

Model no.	d	l	Da	dr	Load Rating Ca(kgf)	Load Rating Co(kgf)	K kgf/μm	Dimension								
								D	A	B	L	W	H	X	Q	n
SFDCR6310-4.8	63	10	6.35	57.90	7725	29495	115	88	135	20	80.5	115	100	8-Φ11	M8*1	4.8*1
SFDCR6310-4.8		10	7.144	57.18	9179	33564	120	93	131	20	82	113	100	8-Φ11	M8*1	4.8*1
SFDCR6312-4.8		12	7.938	56.37	10534	36804	124	95	135	20	92.5	115	100	8-Φ11	M8*1	4.8*1
SFDCR6316-4.8		16			10515	36754	127				113.5					
SFDCR6316-4.8		16	9.525	55.25	13477	44049	132	102	147	25	116	127	112	8-Φ14	M8*1	4.8*1
SFDCR6320-4.8		20			13447	43973	134				136.5					
SFDCR6340-3.8		40			13203	43360	134				196.5					
SFDCR6316-4.8		16	12.7	53.00	19712	58580	144	115	159	28	125	137	125	8-Φ14	M8*1	4.8*1
SFDCR6320-4.8		20			19670	58482	145				145					
SFDCR8010-4.8		80	10	6.35	74.90	8623	38372	133	105	152	20	80.5	132	122	8-Φ11	M8*1
SFDCR8012-4.8	12		7.938	73.37	11758	47607	135	110	157	20	91.5	137	120	8-Φ11	M8*1	4.8*1
SFDCR8016-4.8	16		9.525	72.25	15190	57374	156	118	165	25	116	145	130	8-Φ14	M8*1	4.8*1
SFDCR8020-4.8	20				15169	57312	159				135					
SFDCR8016-4.8	16		12.7	70.00	22107	74477	165	132	176	28	125	154	145	8-Φ14	M8*1	4.8*1
SFDCR8030-4.8	30				21972	74128	170				199					
SFDCR10030-3.8	30		9.525	92.25	13428	55863	151	145	192	25	163	172	158	8-Φ14	M8*1	3.8*1
SFDCR10040-3.8	40				13370	55675	152				203					
SFDCR10020-4.8	20	12.7			90.00	24549	94184				194					

Note: A star symbol can be used to make a left-hand screw.

1. The values marked with "*" in the table can be used for left-hand lead screws, with nut dimensions identical to those of right-hand lead screws.

2. The stiffness values shown in the table represent spring constants. Each constant is determined by applying a pre-load of 10% of the axial basic rated dynamic load (Ca) and then applying an axial load equal to three times the pre-load, with both the load and elastic deformation taken into account.

This value does not include the stiffness values of the nut mounting section and related components. Therefore, please consider 80% of the values in the table as a rough guideline.

If the actual pre-load (Fa0) is not 0.1Ca, the stiffness value (Kn) can be calculated using the following formula.

$$K_N = K \left(\frac{Fa_0}{0.3Ca} \right)^3$$

K: The rigid values in the size table

If you need to produce different numbers of coils from the table above, please consult SHAC.

Size Table of DFNU Ball Screw

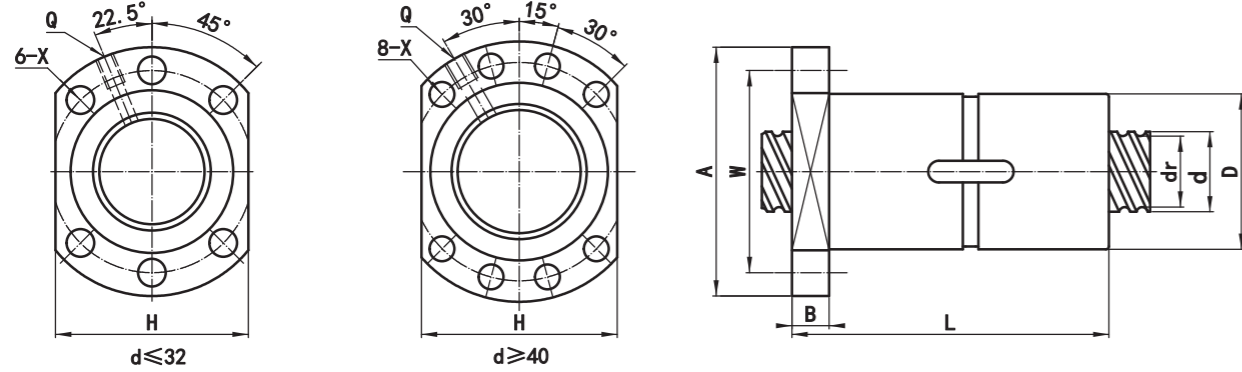

Model no.	d	l	Da	dr	Load Rating Ca(kgf)	Load Rating Co(kgf)	K kgf/μm	Dimension																
								D	A	B	L	W	H	X	Q	n								
★ DFNUR1604-4	16	4	2.381	14.38	974	2408	49											1*4						
★ DFNUR1605-4		5	3.175	13.82	1381	3055	51	28	48	10	91	38	40	6-Φ5.5	M6*1			1*4						
★ DFNUR1610-3		10			1105	2403	41						118						1*3					
★ DFUR2004-3	20	4	2.381	18.38	833	2242	43	36	58	10	82	47	44	6-Φ6.6	M6*1			1*3						
★ DFNUR2005-4		5	3.175	17.82	1552	3879	60				95													1*4
★ DFUR2504-4	25	4	2.381	23.38	1181	3799	66	40	62	10	80	51	48	6-Φ6.6	M6*1			1*4						
★ DFNUR2505-4		5	3.175	22.82	1726	4909	69				95													1*4
★ DFNUR2510-4		10	4.762	21.74	2957	7302	78				12					138.5								
★ DFNUR3205-4	32	5	3.175	29.82	1924	6350	82	50	80	12	97	65	62	6-Φ9	M6*1			1*4						
★ DFNUR3210-4		10	6.35	27.65	4810	12220	96				153													
★ DFNUR4005-4	40	5	3.175	37.82	2112	7996	97	63	93	14	101	78	70	8-Φ9	M8*1			1*4						
★ DFNUR4010-4		10	6.35	35.65	5405	15516	112				157													
★ DFNUR5010-4	50	10	6.35	45.65	6010	19634	131	75	110	16	157	93	85	8-Φ11	M8*1			1*4						
★ DFNUR6310-4	63	10	6.35	58.65	6726	25384	154	90	125	18	182	108	95	8-Φ11	M8*1			1*4						
★ DFUR6320-4		20	9.525	56.49	11456	36691	172									95	135	20	290	115	100	8-Φ13.5	M8*1	
★ DFNUR8010-4	80	10	6.35	75.65	7353	31986	172	105	145	20	170.5	125	110	8-Φ13.5	M8*1			1*4						
★ DFNUR8020-4		20	9.525	73.49	12924	47796	209									125	165	25	285	145	130			

Note: A star symbol can be used to make a left-hand screw.

The stiffness values shown in the table represent the spring constants. Each constant is determined by applying a pre-load equivalent to 10% of the axial basic rated dynamic load (Ca) and then applying an axial load three times the pre-load amount, with the load and elastic deformation measured under these conditions.

These values do not include the stiffness values of the nut mounting section and related components. Therefore, please consider 80% of the values in the table as a rough guideline.

If the actual pre-load load (Fa0) is not 0.1Ca, the stiffness value (Kn) can be calculated using the following formula.

$$K_N = K \left(\frac{Fa_0}{0.3Ca} \right)^{\frac{1}{3}}$$

If you need to produce different numbers of coils as shown in the table above, please consult SHAC.

K: The rigid values in the size table

Size Table of SFNU Ball Screw

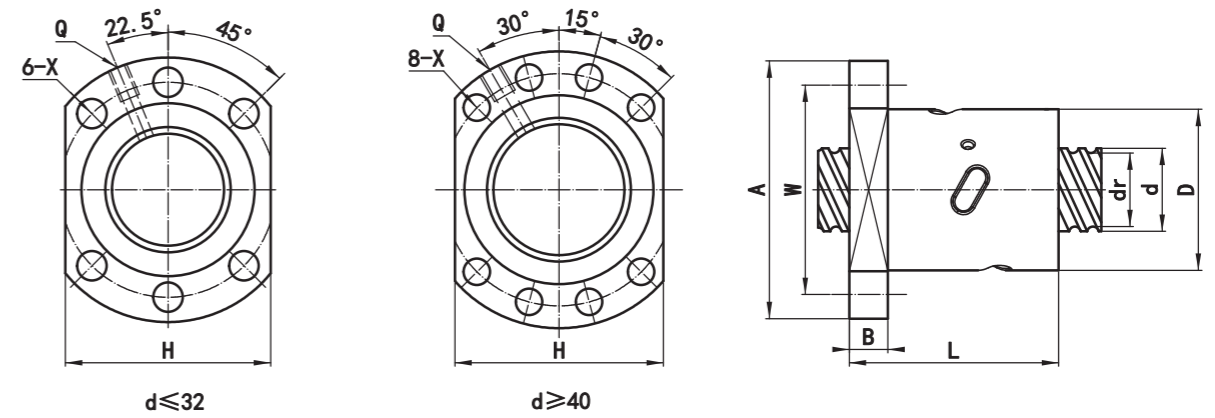

Model no.	d	l	Da	dr	Load Rating Ca(kgf)	Load Rating Co(kgf)	K kgf/μm	Dimension																				
								D	A	B	L	W	H	X	Q	n												
★ SFNUR1204-3	12	4	2.5	9.74	678	1321	20	24	40	10	35	32	30	6-Φ4.5	M6*1			1*3										
★ SFNUR1204-4					40						26							1*4										
★ SFNUR1604-4	16	5	3.175	13.82	974	2408	32	28	48	10	40	38	40	6-Φ5.5	M6*1			1*4										
★ SFNUR1605-3					42						25							1*3										
★ SFNUR1605-4					45						33							1*4										
★ SFNUR1610-3					57						27							1*3										
★ SFUR2004-3					4	2.381	18.38				833					2242	28					42	47	44	6-Φ6.6	M6*1		
★ SFNUR2005-3	20	5	3.175	17.82	1212	2909	29	51									1*3											
★ SFNUR2005-4					39																1*4							
★ SFUR2504-4	25	5	3.175	22.82	1181	3799	43	40	62	10	42	51	48	6-Φ6.6	M6*1			1*4										
★ SFNUR2505-3					1348	3681	34																				1*3	
★ SFNUR2505-4					1726	4909	45																					1*4
★ SFNUR2510-3					2309	5477	38															70						1*3
★ SFNUR2510-4					2957	7302	50															80						1*4
★ SFNUR3205-4	32	5	3.175	29.82	1924	6350	53	50	80	12	52	65	62	6-Φ9	M6*1			1*4										
★ SFNUR3210-3					3755	9165	47				74																1*3	
★ SFNUR3210-4					4810	12220	62				85																	1*4
★ SFNUR4005-4	40	5	3.175	37.82	2112	7996	62	63	93	14	55	78	70	8-Φ9	M8*1			1*4										
★ SFNUR4010-3					4220	11637	55				71																1*3	
★ SFNUR4010-4					5405	15516	72				88																	1*4
★ SFNUR5010-4	50	10	6.35	45.65	6010	19634	84	75	110	16	88	93	85	8-Φ11	M8*1			1*4										
★ SFNUR6310-4	63	10	6.35	58.65	6726	25384	99	90	125	18	93	108	95	8-Φ11	M8*1			1*4										
★ SFUR6320-4					20	9.525	56.49				11746					38517	114	95	135	20	149	115	100	8-Φ13.5			1*4	
★ SFNUR8010-4	80	10	6.35	75.65	7353	31986	111	105	145	20	98	125	110	8-Φ13.5	M8*1			1*4										
★ SFNUR8020-4					20	9.525	73.49				12924					47796	143	125	165	25	154	145	130					1*4

Note: A star symbol can be used to make a left-hand screw.

The stiffness values shown in the table represent the spring constants. Each constant is determined by applying a pre-load equivalent to 10% of the axial basic rated dynamic load (Ca) and then applying an axial load three times the pre-load amount, with the load and elastic deformation measured under these conditions.

These values do not include the stiffness values of the nut mounting section and related components. Therefore, please consider 80% of the values in the table as a rough guideline.

If the actual pre-load load (Fa0) is not 0.1Ca, the stiffness value (Kn) can be calculated using the following formula.

$$K_N = K \left(\frac{Fa_0}{0.3Ca} \right)^{\frac{1}{3}}$$

If you need to produce different numbers of coils as shown in the table above, please consult SHAC.

K: The rigid values in the size table

SFUH Special for Electric Cylinders

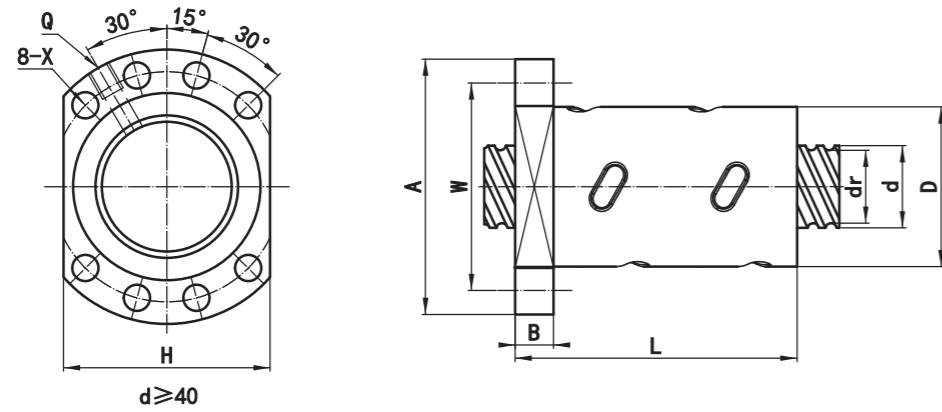

Model no.	d	l	Da	dr	Load Rating Ca(kgf)	Dimension						
						D	A	B	L	W	X	n
SFUH2510-T4	25	10	4.762	3314	8391	40	62	12	75	51	Φ6.6	1*4
SFUH3210-T5	32	10	6.35	6531	17553	53	83	12	88	68	Φ9	1*5
SFUH4010-T6	40	10	6.35	8585	26744	63	93	14	100	78	Φ9	1*6
SFUH5010-T6	50	10	6.35	9547	33844	75	109	16	102	93	Φ11	1*6
SFUH5012-T6	50	12	7.144	11131	37415	75	118	18	136	95	Φ11	1*6
SFUH6320-T6	63	20	9.525	18195	63244	95	135	23	202	115	Φ13.5	1*6
SFUH8020-T8	80	20	12.7	38391	142490	118	178	28	234	148	Φ17.5	1*8
SFUH8025-T6	80	25	15.875	39855	131396	128	178	28	248	148	Φ17.5	1*6
SFUH10020-T6	100	20	15.875	44875	167131	150	195	28	213	172	Φ17.5	1*6

Note: The nut does not have an oil injection hole or a dust ring. The listed models are the preferred sizes for electric cylinder nuts

Specifications with asterisks can be produced using rolling technology

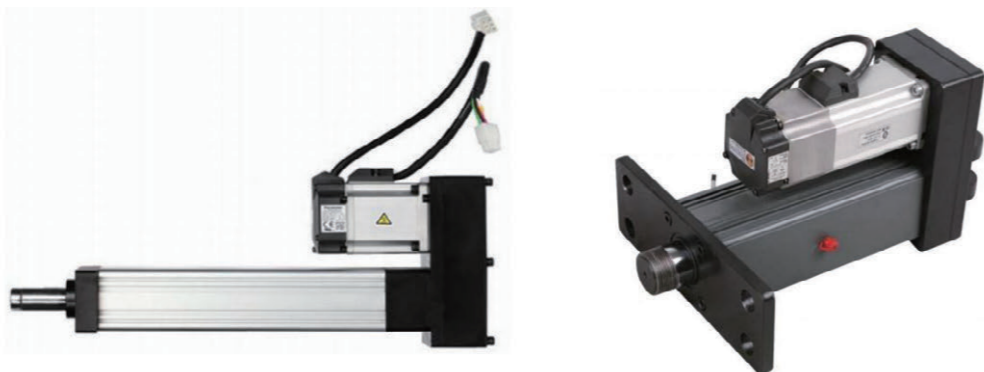

Size Table of SFK Ball Screws (Heavy)

SFK multi array, electric cylinder specific

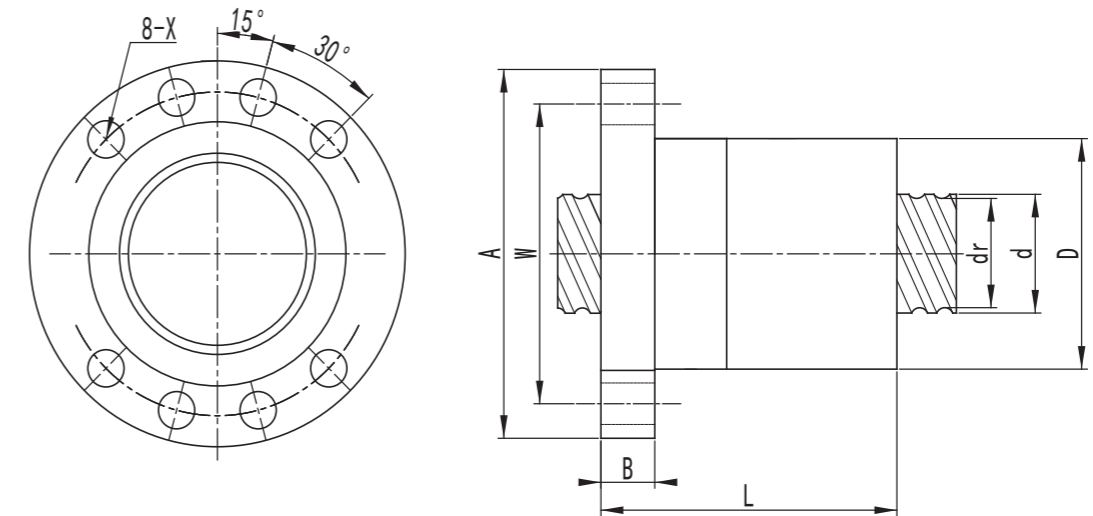

Model no.	d	l	Da	dr	Load Rating Ca(kgf)	Dimension						
						D	A	B	L	W	X	n
SFKHR5010-8	50	10	7.144	14235	49964	75	109	16	94	93	Φ11	1*8
SFKHR5020-7	50	20	7.144	12629	43440	75	109	16	154	93	Φ11	1*7
SFKHR6320-8	63	20	12.7	34205	112007	100	139	28	184	120	Φ13.5	1*8
SFKHR8020-8	80	20	12.7	38391	142490	125	169	28	182	150	Φ13.5	1*8
SFKHR10020-8	100	20	12.7	42691	180384	150	207	32	184	180	Φ17.5	1*8
SFKHR10025-8	100	25	15.875	57392	222606	150	207	32	227	180	Φ17.5	1*8
SFKHR12525-8	125	25	15.875	63766	281877	180	249	32	227	216	Φ22	1*8

Note: The nut does not have an oil injection hole or a dust ring. The listed models are the preferred sizes for electric cylinder nuts

Size Table of SFY Ball Screw

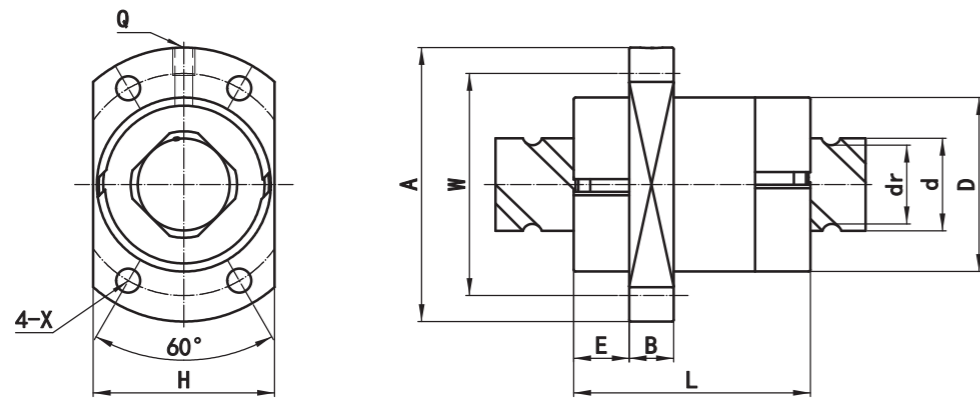

Model no.	d	l	Da	dr	Load Rating Ca(kgf)	Load Rating Co(kgf)	K kgf/μm	Dimension										
								D	A	E	B	L	W	H	X	Q	n	
SFYR1616-3.6	16	16	2.778	13.81	1088	2554	31	32	53	10	10	45	42	34	4-Φ4.5	M6*1	1.8*2	
SFYR1632-1.6		32			42.5	0.8*2												
SFYR2020-3.6	20	20	3.175	17.5	1390	3511	35	39	62	13	10	52	50	50	41	4-Φ5.5	M6*1	1.8*2
SFYR2040-1.6		40			50	0.8*2												
SFYR2040-3.6		40			90	1.8*2												
SFYR2525-3.6	25	25	3.969	21.94	2078	5489	44	47	74	15	12	64	60	49	4-Φ6.6	M6*1	1.8*2	
SFYR2525-5.6					89	2.8*2												
SFYR2550-1.6		50			60	0.8*2												
SFYR2550-3.6					110	1.8*2												
SFYR3232-3.6	32	32	4.762	28.37	2939	8307	53	58	92	17	12	78	74	60	4-Φ9	M6*1	1.8*2	
SFYR3232-5.6		110			2.8*2													
SFYR3264-1.6		64			71	0.8*2												
SFYR4040-3.6	40	40	6.35	35.25	4840	14057	67	73	114	19.5	15	99	93	75	4-Φ11	M6*1	1.8*2	
SFYR4040-5.6					139	2.8*2												
SFYR4080-1.6		80			91	0.8*2												
SFYR5050-3.6	50	50	7.938	44.12	7232	21970	83	90	135	21.5	20	117	112	92	4-Φ14	M6*1	1.8*2	
SFYR5050-5.6					167	2.8*2												
SFYR50100-1.6		100			111	0.8*2												

The stiffness values shown in the table represent the spring constants. Each constant is determined by applying a preload equivalent to 10% of the axial basic rated dynamic load (Ca) and then applying an axial load three times the preload amount, with the load and elastic deformation measured under these conditions.

These values do not include the stiffness values of the nut mounting section and related components; therefore, please consider 80% of the values in the table as a rough guideline.

If the actual preload load (Fa0) is not 0.1Ca, the stiffness value (Kn) can be calculated using the following formula.

$$K_N = K \left(\frac{Fa_0}{0.3Ca} \right)^{\frac{1}{3}}$$

If you need to produce different numbers of coils as shown in the table above, please consult SHAC.

K: The rigid values in the size table

Size Table of OFNU Ball Screw

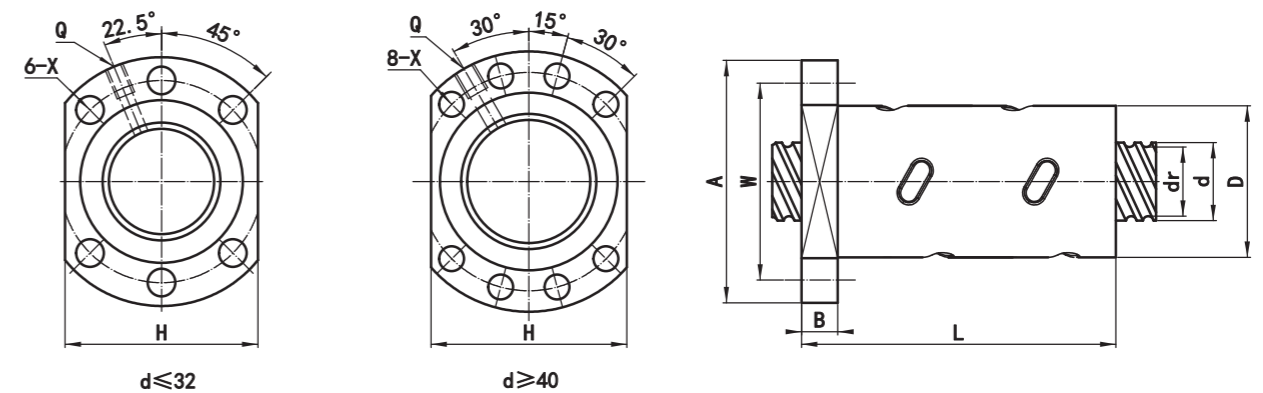

Model no.	d	l	Da	dr	Load Rating Ca(kgf)	Load Rating Co(kgf)	K kgf/μm	Dimension									
								D	A	B	L	W	H	X	Q	n	
★ OFNUR1605-4	16	5	3.175	13.82	1381	3055	45	28	48	10	75	38	40	6-Φ5.5	M6*1	1*8	
★ OFNUR2005-4	20	5	3.175	17.82	1552	3879	52	36	58	10	85	47	44	6-Φ6.6	M6*1	1*8	
★ OFNUR2505-4	25	5	3.175	22.82	1726	4909	61	40	62	10	86	51	48	6-Φ6.6	M6*1	1*8	
★ OFNUR2510-4		10	4.762	21.74	2957	7302	69			12	130					1*8	
★ OFNUR3205-4	32	5	3.175	29.82	1924	6350	71	50	80	12	87	65	62	6-Φ9	M6*1	1*8	
★ OFNUR3210-4		10	6.35	27.65	4810	12220	85			145	1*8						
★ OFNUR4005-4	40	5	3.175	37.82	2112	7996	82	63	93	14	90	78	70	8-Φ9	M8*1	1*8	
★ OFNUR4010-4		10	6.35	35.65	5405	15516	98			148	1*8						
★ OFNUR5010-4	50	10	6.35	45.65	6010	19634	113	75	110	16	148	93	85	8-Φ11	M8*1	1*8	

Note: A star symbol can be used to make a left-hand screw.

The stiffness values shown in the table represent the spring constants. Each constant is determined by applying a preload equivalent to 10% of the axial basic rated dynamic load (Ca) and then applying an axial load three times the preload amount, with the load and elastic deformation measured under these conditions.

These values do not include the stiffness values of the nut mounting section and related components; therefore, please consider 80% of the values in the table as a rough guideline.

If the actual preload load (Fa0) is not 0.1Ca, the stiffness value (Kn) can be calculated using the following formula.

$$K_N = K \left(\frac{Fa_0}{0.3Ca} \right)^{\frac{1}{3}}$$

K: The rigid values in the size table

If you need to produce different numbers of coils as shown in the table above, please consult SHAC.

Size Table of OFNI Ball Screw

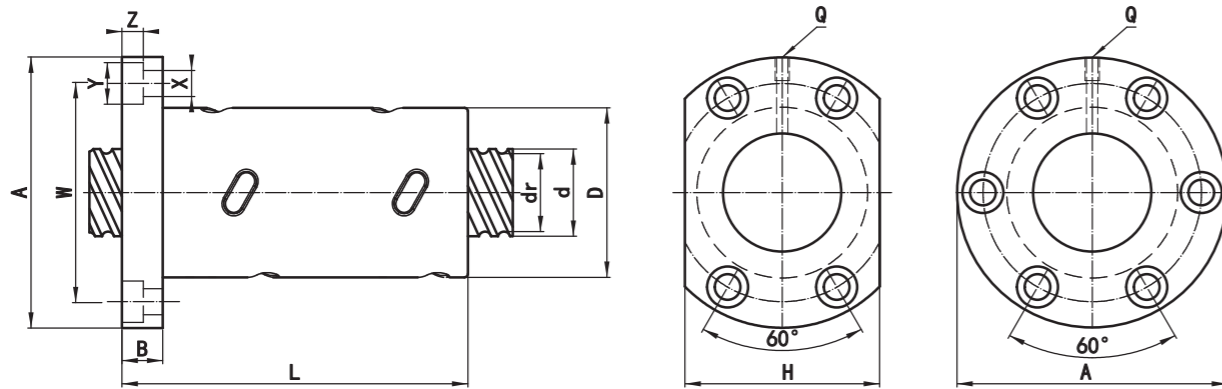

Model no.	d	l	Da	dr	Load Rating Ca(kgf)	Load Rating Co(kgf)	K kgf/μm	Dimension										
								D	A	B	L	W	H	X	Y	Z	Q	n
★ OFNIR1605-4	16	5	3.175	13.82	1381	3055	45	30	49	10	75	39	34	4.5	8	4.5	M6*1	1*8
★ OFNIR2005-4	20	5	3.175	17.82	1552	3879	52	34	57	11	85	45	40	5.5	9.5	5.5	M6*1	1*8
★ OFNIR2505-4	25	5	3.175	22.82	1726	4909	61	40	63	11	86	51	46	5.5	9.5	5.5	M8*1	1*8
★ OFNIR2510-4		10	4.762	21.74	2957	7302	69	46	72	12	130	58	52	6.5	11.5	6.5	M6*1	1*8
★ OFNIR3205-4	32	5	3.175	29.82	1924	6350	71	46	72	12	87	58	52	6.5	11.5	6.5	M8*1	1*8
★ OFNIR3210-4		10	6.35	27.65	4810	12220	85	54	88	15	145	70	62	9	14	9	M8*1	1*8
★ OFNIR4005-4	40	5	3.175	37.82	2112	7996	82	56	90	15	90	72	64	9	14	8.5	M8*1	1*8
★ OFNIR4010-4		10	6.35	35.65	5405	15516	98	62	104	18	148	82	70	11	17.5	11	M8*1	1*8
★ OFNIR5010-4	50	10	6.35	45.65	6010	19634	113	72	114	18	148	92	82	11	17.5	11	M8*1	1*8
OFNIR6310-4	63	10	6.35	58.65	6726	12384	132	85	131	22	153	107	95	14	20	13	M8*1	1*8
OFIR8010-4	80	10	6.35	75.65	7353	31986	153	105	150	22	153	127	115	14	20	13	M8*1	1*8

Note: A star symbol can be used to make a left-hand screw.

The stiffness values shown in the table represent the spring constants. Each constant is determined by applying a pre-load equivalent to 10% of the axial basic rated dynamic load (Ca) and then applying an axial load three times the pre-load amount, with the load and elastic deformation measured under these conditions.

These values do not include the stiffness values of the nut mounting section and related components; therefore, please consider 80% of the values in the table as a rough guideline.

If the actual pre-load load (Fa0) is not 0.1Ca, the stiffness value (Kn) can be calculated using the following formula.

$$K_N = K \left(\frac{Fa_0}{0.3Ca} \right)^{\frac{1}{3}}$$

If you need to produce different numbers of coils as shown in the table above, please consult SHAC.

K: The rigid values in the size table

Size Table of DFS Ball Screw

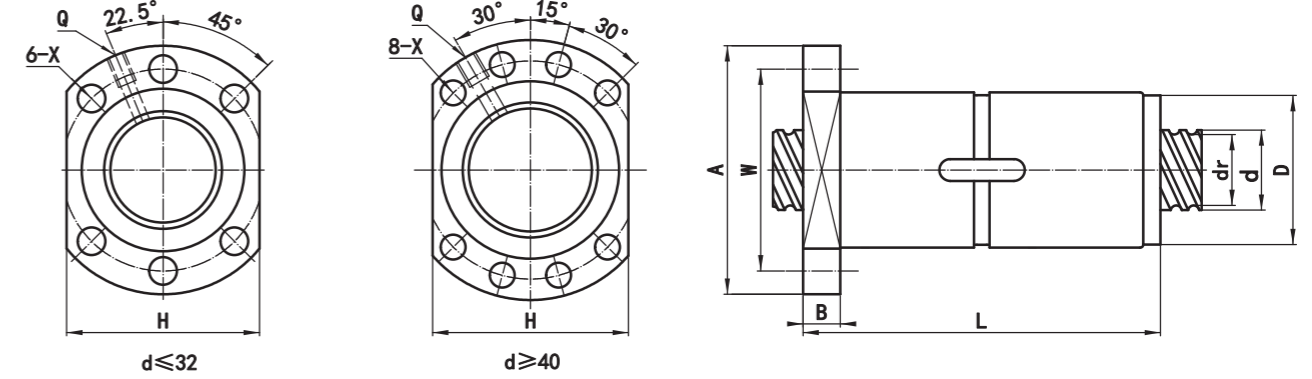

Model no.	d	l	Da	dr	Load Rating Ca(kgf)	Load Rating Co(kgf)	K kgf/μm	Dimension									
								D	A	B	L	W	H	X	Q	n	
★ DFSR1605-3.8	14.8	5	2.778	12.83	1122	2492	48	28	48	10	72.5	38	40	6-Φ5.5	M6*1	3.8*1	
DFSR1610-2.8		10			892	1949	38				97					2.8*1	
DFSR2005-3.8	20	5	3.175	17.82	1552	3879	60	36	58	10	75	47	44	6-Φ6.6	M6*1	3.8*1	
DFSR2010-3.8		10			1586	4039	63				120						
DFSR2505-3.8	25	5	3.175	22.82	1726	4909	69	40	62	10	72.5	51	48	6-Φ6.6	M6*1	3.8*1	
★ DFSR2510-3.8		10			1714	4882	72				117						
DFSR3205-3.8	32	5	3.175	29.82	1924	6350	82	50	80	12	82	65	62	6-Φ9	M6*1	3.8*1	
DFSR3210-3.8	31	10	3.969	28.29	2574	7645	88	50	80	13	122	65	62	6-Φ9	M6*1	3.8*1	
DFSR3220-2.8		20			2025	5879	69				160					2.8*1	
DFSR4005-3.8	40	5	3.175	37.82	2112	7996	97	63	93	15	85	78	70	8-Φ9	M8*1	3.8*1	
DFSR4010-3.8	38	10	6.35	33.02	5281	14676	110	63	93	14	123	78	70	8-Φ9	M8*1	3.8*1	
DFSR4020-2.8		20			4073	10902	85				162					2.8*1	
DFSR5005-3.8	50	5	3.175	47.84	2309	10055	112	75	110	15	85	93	85	8-Φ11	M8*1	3.8*1	
DFSR5010-3.8	48	10	6.35	43.66	5898	18811	128	75	110	18	138	93	85	8-Φ11	M8*1	3.8*1	
DFSR5020-3.8		20			6014	19478	137				147						
DFSR5050-1.8		50			3229	9732	70				218						1.8*1

Note: A star symbol can be used to make a left-hand screw.

The stiffness values shown in the table represent the spring constants. Each constant is determined by applying a pre-load equivalent to 10% of the axial basic rated dynamic load (Ca) and then applying an axial load three times the pre-load amount, with the load and elastic deformation measured under these conditions.

These values do not include the stiffness values of the nut mounting section and related components; therefore, please consider 80% of the values in the table as a rough guideline.

If the actual pre-load load (Fa0) is not 0.1Ca, the stiffness value (Kn) can be calculated using the following formula.

$$K_N = K \left(\frac{Fa_0}{0.3Ca} \right)^{\frac{1}{3}}$$

If you need to produce different numbers of coils as shown in the table above, please consult SHAC.

K: The rigid values in the size table

Size Table of SFS Ball Screw

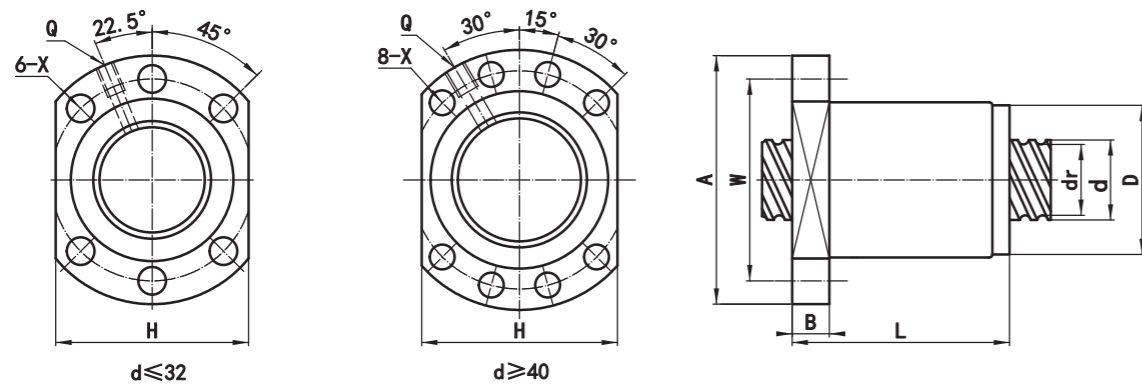

Size Table of SFS Ball Screw-2

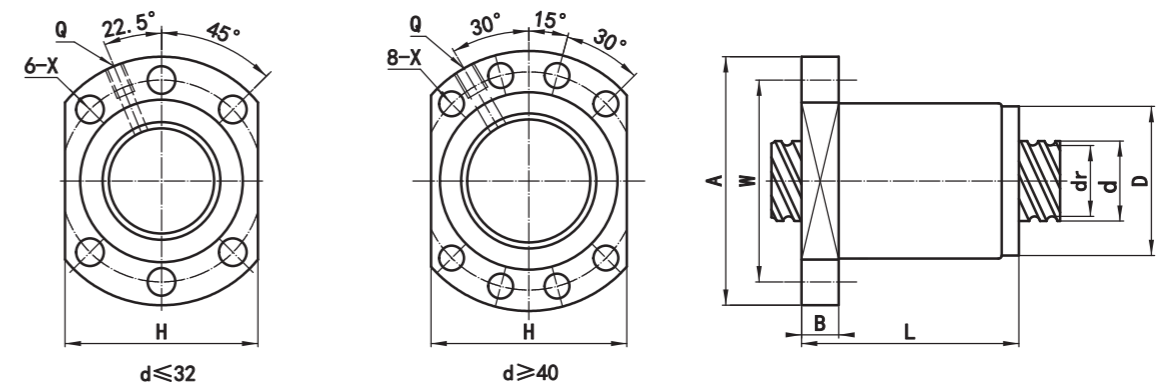

Model no.	d	l	Da	dr	Load Rating Ca(kgf)	Load Rating Co(kgf)	K kgf/μm	Dimension								
								D	A	B	L	W	H	X	Q	n
SFSR1205-2.8	12	5	2.5	9.74	678	1317	20	24	40	10	31	32	30	6-Φ4.5	-	2.8*1
SFSR1210-2.8		10			49											
★ SFSR1605-3.8	14.8	5	2.778	12.83	1122	2492	31	28	48	10	37.5	38	40	6-Φ5.5	M6*1	3.8*1
SFSR1610-2.8		10			47	2.8*1										
SFSR1616-1.8		16			45	1.8*1										
SFSR1620-1.8		20			56	2.8*1										
SFSR2005-3.8	20	5	3.175	17.82	1552	3879	39	36	58	10	40	47	44	6-Φ6.6	M6*1	3.8*1
SFSR2010-3.8		10			60	3.8*1										
SFSR2020-1.8		20			57	1.8*1										
★ SFSR2505-3.8	25	5	3.175	22.82	1726	4909	45	40	62	10	40	51	48	6-Φ6.6	M6*1	3.8*1
SFSR2510-3.8		10			62	3.8*1										
SFSR2525-1.8		25			12	70	1.8*1									
SFSR2525-2.8					25	95	2.8*1									
SFSR3205-3.8	32	5	3.175	29.82	1924	6350	53	50	80	12	42	65	62	6-Φ9	M6*1	3.8*1
SFSR3210-3.8	31	10	3.969	28.29	2574	7645	57	50	80	12	62	65	62	6-Φ9	M6*1	3.8*1
SFSR3220-2.8		20			80	2.8*1										
SFSR3232-1.8		32			84	1.8*1										
SFSR3232-2.8					116	2.8*1										

Model no.	d	l	Da	dr	Load Rating Ca(kgf)	Load Rating Co(kgf)	K kgf/μm	Dimension								
								D	A	B	L	W	H	X	Q	n
SFSR4005-3.8	40	5	3.175	37.82	2112	7997	62	63	93	15	45	78	70	8-Φ9	M8*1	3.8*1
SFSR4010-3.8	38	10	6.35	33.02	5281	14676	71	63	93	14	63	78	70	8-Φ9	M8*1	3.8*1
SFSR4020-2.8		20			82	2.8*1										
SFSR4040-1.8		40			105	1.8*1										
SFSR4040-2.8					145	2.8*1										
SFSR5005-3.8	50	5	3.175	47.84	2309	10055	72	75	110	15	45	93	85	8-Φ11	M8*1	3.8*1
SFSR5010-3.8	48	10	6.35	43.66	5898	18811	83	75	110	18	68	93	85	8-Φ11	M8*1	3.8*1
SFSR5020-3.8		20			108	3.8*1										
SFSR5050-1.8		50			125	1.8*1										
SFSR5050-2.8					175	2.8*1										

Note: A star symbol can be used to make a left-hand screw.

The stiffness values shown in the table represent the spring constants. Each constant is determined by applying a preload equivalent to 10% of the axial basic rated dynamic load (Ca) and then applying an axial load three times the preload amount, with the load and elastic deformation measured under these conditions.

These values do not include the stiffness values of the nut mounting section and related components; therefore, please consider 80% of the values in the table as a rough guideline.

If the actual preload load (Fa0) is not 0.1Ca, the stiffness value (Kn) can be calculated using the following formula.

If you need to produce different numbers of coils as shown in the table above, please consult SHAC.

$$K_N = K \left(\frac{Fa_0}{0.3Ca} \right)^{\frac{1}{3}}$$

K: The rigid values in the size table

Size Table of DFNI Ball Screw

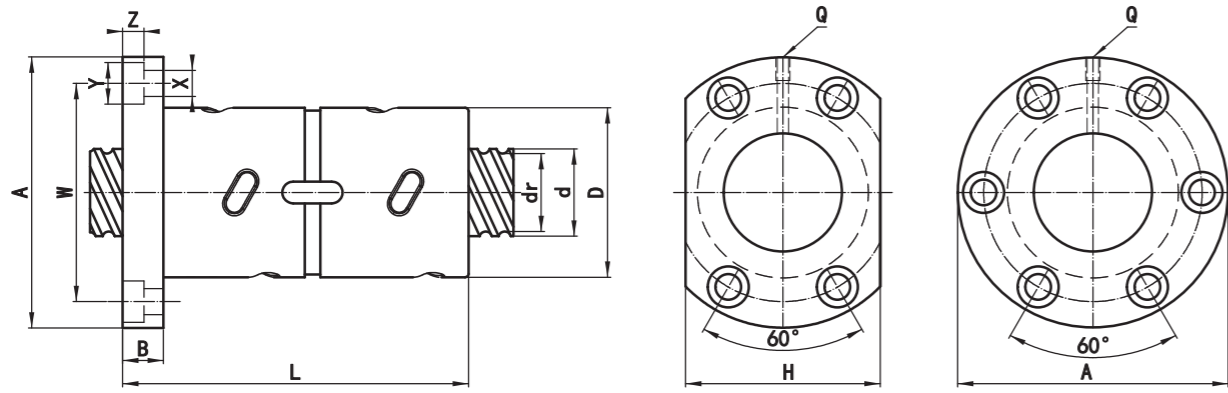

Model no.	d	l	Da	dr	Load Rating Ca(kgf)	Load Rating Co(kgf)	K kgf/μm	Dimension										
								D	A	B	L	W	H	X	Y	Z	Q	n
★ DFNIR1605-4	16	5	3.175	13.82	1381	3055	51	30	49	10	100	39	34	4.5	8	4.5	M6*1	1*4
★ DFNIR1610-3		10	3.175	13.82	1104	2404	41	34	58	10	118	45	34	5.5	9.5	5.5	M6*1	1*3
★ DFNIR2005-4	20	5	3.175	17.82	1552	3879	59	34	57	11	101	45	40	5.5	9.5	5.5	M6*1	1*4
★ DFNIR2505-4	25	5	3.175	22.82	1726	4909	69	40	63	11	101	51	46	5.5	9.5	5.5	M8*1	1*4
★ DFNIR2510-4		10	4.762	21.74	2957	7302	79	46	72	12	145	58	52	6.5	11.5	6.5	M6*1	1*4
★ DFNIR3205-4	32	5	3.175	29.82	1924	6350	80	46	72	12	102	58	52	6.5	11.5	6.5	M8*1	1*4
★ DFNIR3210-4		10	6.35	27.65	4810	12220	97	54	88	15	162	70	62	9	14	9	M8*1	1*4
★ DFNIR4005-4	40	5	3.175	37.82	2112	7996	93	56	90	15	105	72	64	9	14	8.5	M8*1	1*4
★ DFNIR4010-4		10	6.35	35.65	5405	15516	112	62	104	18	165	82	70	11	17.5	11	M8*1	1*4
★ DFNIR5010-4	50	10	6.35	45.65	6010	19634	129	72	114	18	171	92	82	11	17.5	11	M8*1	1*4
★ DFNIR6310-4	63	10	6.35	58.65	6726	12384	150	85	131	22	182	107	95	14	20	13	M8*1	1*4
★ DFNIR8010-4	80	10	6.35	75.65	7353	31986	172	105	150	22	182	127	115	14	20	13	M8*1	1*4

Note: A star symbol can be used to make a left-hand screw.

The stiffness values shown in the table represent the spring constants. Each constant is determined by applying a pre-load equivalent to 10% of the axial basic rated dynamic load (Ca) and then applying an axial load three times the pre-load amount, with the load and elastic deformation measured under these conditions.

These values do not include the stiffness values of the nut mounting section and related components; therefore, please consider 80% of the values in the table as a rough guideline.

If the actual pre-load load (Fa0) is not 0.1Ca, the stiffness value (Kn) can be calculated using the following formula.

$$K_N = K \left(\frac{Fa_0}{0.3Ca} \right)^{\frac{1}{3}}$$

If you need to produce different numbers of coils as shown in the table above, please consult SHAC.

K: The rigid values in the size table

Size Table of SFNI Ball Screw

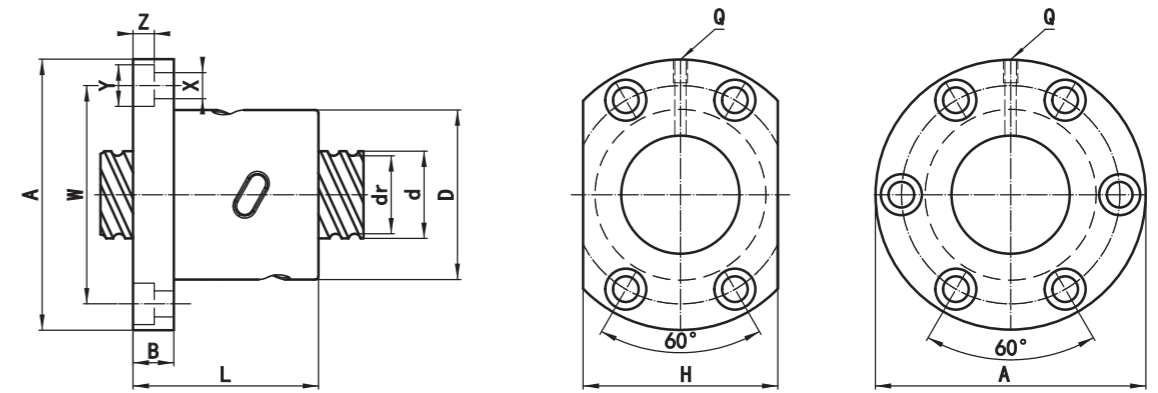

Model no.	d	l	Da	dr	Load Rating Ca(kgf)	Load Rating Co(kgf)	K kgf/μm	Dimension										
								D	A	B	L	W	H	X	Y	Z	Q	n
★ SFNIR1605-4	16	5	3.175	13.82	1381	3055	33	30	49	10	45	39	34	4.5	8	4.5	M6*1	1*4
★ SFNIR1610-3		10			1104	2404	27	34	58		57	45		5.5	9.5	5.5		1*3
★ SFNIR2005-4	20	5	3.175	17.82	1552	3879	38	34	57	11	51	45	40	5.5	9.5	5.5	M6*1	1*4
★ SFNIR2505-4	25	5	3.175	22.82	1726	4909	45	40	63	11	51	51	46	5.5	9.5	5.5	M8*1	1*4
★ SFNIR2510-4		10	4.762	21.74	2957	7302	51	46	72	12	80	58	52	6.5	11.5	6.5	M6*1	1*4
★ SFNIR3205-4	32	5	3.175	29.82	1924	6350	52	46	72	12	52	58	52	6.5	11.5	6.5	M8*1	1*4
★ SFNIR3210-4		10	6.35	27.65	4810	12220	63	54	88	15	85	70	62	9	14	9		1*4
★ SFNIR4005-4	40	5	3.175	37.82	2112	7996	60	56	90	15	55	72	64	9	14	8.5	M8*1	1*4
★ SFNIR4010-4		10	6.35	35.65	5405	15516	72	62	104	18	88	82	70	11	17.5	11		1*4
★ SFNIR5010-4	50	10	6.35	45.65	6010	19634	83	72	114	18	88	92	82	11	17.5	11	M8*1	1*4
★ SFNIR6310-4	63	10	6.35	58.65	6726	12384	97	85	131	22	93	107	95	14	20	13	M8*1	1*4
★ SFNIR8010-4	80	10	6.35	75.65	7353	31986	111	105	150	22	93	127	115	14	20	13	M8*1	1*4

Note: A star symbol can be used to make a left-hand screw.

The stiffness values shown in the table represent the spring constants. Each constant is determined by applying a pre-load equivalent to 10% of the axial basic rated dynamic load (Ca) and then applying an axial load three times the pre-load amount, with the load and elastic deformation measured under these conditions.

These values do not include the stiffness values of the nut mounting section and related components; therefore, please consider 80% of the values in the table as a rough guideline.

If the actual pre-load load (Fa0) is not 0.1Ca, the stiffness value (Kn) can be calculated using the following formula.

$$K_N = K \left(\frac{Fa_0}{0.3Ca} \right)^{\frac{1}{3}}$$

K: The rigid values in the size table

If you need to produce different numbers of coils as shown in the table above, please consult SHAC.

Size Table of SFA Ball Screw

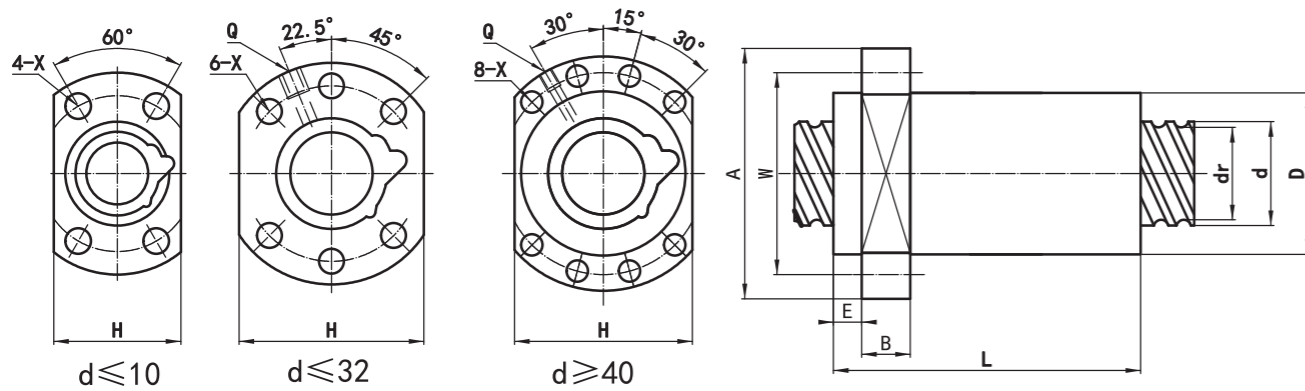

Model no.	d	l	Da	dr	Load Rating Ca(kgf)	Load Rating Co(kgf)	K kgf/μm	Dimension										
								D	A	E	B	L	W	H	X	Q	n	
SFAR0602-3.8	6	2	1.2	5.18	240	436	13	12	24	/	3.5	15	18	16	4-Φ3.4	/	3.8*1	
SFAR0802-3.8	8	2	1.2	7.18	284	611	17	14	27	3	5	17.5	21	18	4-Φ3.4	/	3.8*1	
SFAR0802.5-3.8		2.5			20	20												
SFAR0805-1.8		5			19	19												
SFAR1004-3.8	10	4	2	8.63	600	1208	22	26	46	4	10	30	36	28	4-Φ4.5	M6*1	3.8*1	
SFAR1006-2.8		6	1.5875	8.78	343	717	16	18	35	5	6	26	27	22	4-Φ4.5	/	2.8*1	
SFAR1012-1.8		12			32	32												
SFAR1204-3.8	12	4	2.5	9.74	869	1761	26	24	40	5	10	30	32	30	6-Φ4.5	M6*1	3.8*1	
SFAR1205-2.8		5			676	1317	20					42						2.8*1
SFAL1205-2.8		10			655	1286	19					50						1.8*1
SFAR1210-2.8		10			655	1286	19					50						1.8*1
SFAR1220-1.8		20			449	891	12					50						1.8*1
SFAR1605-3.8	14.8	5	2.778	12.83	1122	2492	31	28	48	5	10	31	38	40	6-Φ5.5	M6*1	3.8*1	
SFAL1605-3.8		10			892	1949	24					42						2.8*1
SFAR1610-2.8		10			606	1261	16					43						1.8*1
SFAR1616-1.8		16			858	1891	23					59						2.8*1
SFAR1616-2.8		16			858	1891	23					59						2.8*1
SFAR1620-1.8		20			607	1297	16					50						1.8*1
SFAR2005-3.8	20	5	3.175	17.82	1552	3879	39	36	58	7	10	33	47	44	6-Φ6.6	M6*1	3.8*1	
SFAR2010-3.8		10			1586	4039	41					52						1.8*1
SFAR2020-1.8		20			839	1951	20					72						2.8*1
SFAR2020-2.8		20			1189	2926	30					72						2.8*1

Size Table of SFA Ball Screw-2

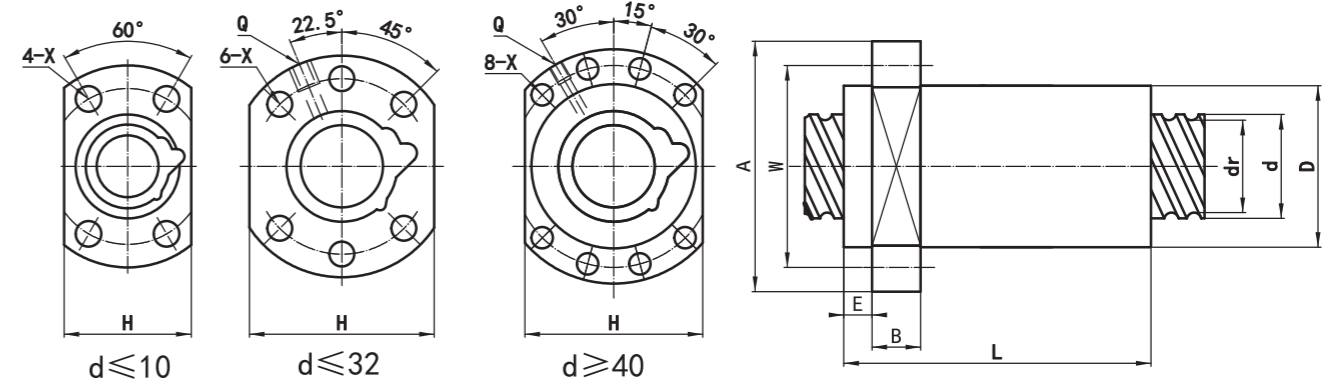

Model no.	d	l	Da	dr	Load Rating Ca(kgf)	Load Rating Co(kgf)	K kgf/μm	Dimension										
								D	A	E	B	L	W	H	X	Q	n	
SFAR2505-3.8	25	5	3.175	22.82	1726	4909	45	40	62	7	10	33	51	48	6-Φ6.6	M6*1	2.8*2	
SFAR2510-3.8		10			52	76	85				6-Φ6.6	M6*1						2.8*1
SFAR2520-2.8		20			76													
SFAR2525-1.8	25	5	3.175	29.82	923	2446	24	50	80	9	12	35	65	62	6-Φ9	M6*1	3.8*1	
SFAR2525-2.8					25	1309	3669											35
SFAR3205-3.8	32	5	3.175	29.82	1924	6350	53	50	80	9	12	35	65	62	6-Φ9	M6*1	3.8*1	
SFAR3210-3.8	31	10	3.969	28.29	2574	7645	57	50	80	9	12	53	65	62	6-Φ9	M6*1	3.8*1	
SFAR3220-2.8		20			2025	5879	45					72						2.8*1
SFAR3232-1.8		32			1378	3810	29					78						1.8*1
SFAR3232-2.8		32			1952	5715	43					110						2.8*1
SFAR4005-3.8	40	5	3.175	37.82	2112	7997	62	63	93	9	15	39	78	70	8-Φ9	M8*1	3.8*1	
SFAR4010-3.8	38	10	6.35	33.02	5281	14676	71	63	93	9	14	57	78	70	8-Φ9	M8*1	3.8*1	
SFAR4020-2.8		20			4073	10902	55					78						2.8*1
SFAR4040-1.8		40			2836	7376	37					96						1.8*1
SFAR4040-2.8		40			4019	11063	54					136						2.8*1
SFAR5005-3.8	50	5	3.175	47.84	2309	10055	72	75	110	10.5	15	42	93	85	8-Φ11	M8*1	3.8*1	
SFAR5010-3.8	48	10	6.35	43.66	5898	18811	83	75	110	10.5	18	57	93	85	8-Φ11	M8*1	3.8*1	
SFAR5020-3.8		20			6014	19478	89					98						1.8*1
SFAR5050-1.8		50			3229	9732	45					117						2.8*1
SFAR5050-2.8		50			4576	14597	66					167						2.8*1

The stiffness values shown in the table represent the spring constants. Each constant is determined by applying a pre-load equivalent to 10% of the axial basic rated dynamic load (Ca) and then applying an axial load three times the pre-load amount, with the load and elastic deformation measured under these conditions.

These values do not include the stiffness values of the nut mounting section and related components; therefore, please consider 80% of the values in the table as a rough guideline.

If the actual pre-load load (Fa0) is not 0.1Ca, the stiffness value (Kn) can be calculated using the following formula.

$$K_N = K \left(\frac{Fa_0}{0.3Ca} \right)^{\frac{1}{3}}$$

If you need to produce different numbers of coils as shown in the table above, please consult SHAC.

K: The rigid values in the size table

Size Table of SFK Ball Screw

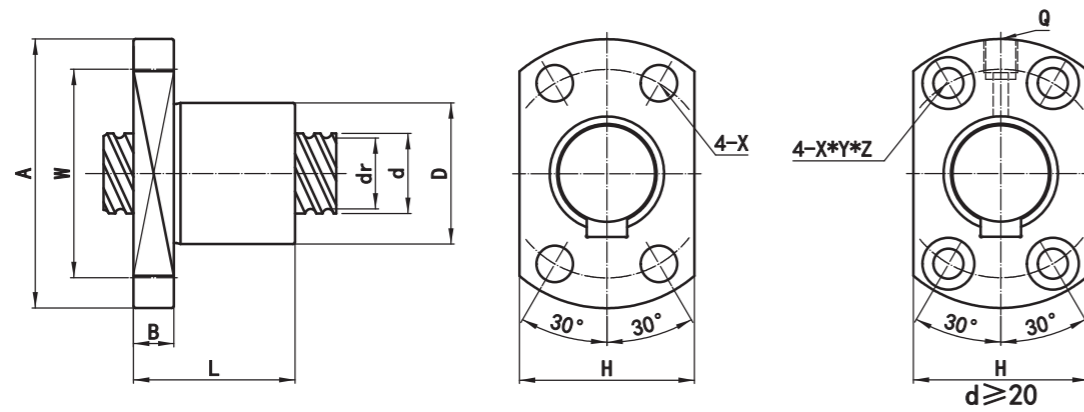

Model no.	d	l	Da	dr	Load Rating Ca(kgf)	Load Rating Co(kgf)	K kgf/μm	Dimension										
								D	A	B	L	W	H	X	Y	Z	Q	n
SFKR0401-2	4	1	0.8	3.45	64	97	5	10	20	3	12	15	14	2.9	-	-	-	1*2
SFKR0601-4	6	1	0.8	5.45	142	299	12	12	24	4	14	18	16	3.4	-	-	-	1*4
SFKR0801-4	8	1	0.8	7.38	162	403	14	14	27	4	14	21	18	3.4	-	-	-	1*4
SFKR0802-4		2	1.2		5	24	1*4											
SFKR1002-4	10	2	1.2	9.18	311	759	19	18	35	5	24	27	22	4.5	-	-	-	1*4
SFKR1202-4	12	2	1.2	11.18	334	907	22	20	37	5	24	29	24	4.5	-	-	-	1*4
SFKR1402-4	14	2	1.2	13.18	355	1054	23	21	40	6	24	31	26	5.5	-	-	-	1*4
SFKR1602-4	16	2	1.2	15.18	373	1201	26	25	43	10	40	35	29	5.5	-	-	-	1*4
SFKR2002-4	20	2	1.2	19.18	581	2287	47	50	80	15	55	65	68	6.5	10.5	6	M6*1	1*6
SFKR2502-4	25	2	1.2	24.18	540	2383	46	50	80	13	43	65	68	6.5	10.5	6	M6*1	1*5

The stiffness values shown in the table represent the spring constants. Each constant is determined by applying a preload equivalent to 10% of the axial basic rated dynamic load (Ca) and then applying an axial load three times the preload amount, with the load and elastic deformation measured under these conditions.

These values do not include the stiffness values of the nut mounting section and related components; therefore, please consider 80% of the values in the table as a rough guideline.

If the actual preload load (Fa0) is not 0.1Ca, the stiffness value (Kn) can be calculated using the following formula.

$$K_N = K \left(\frac{Fa_0}{0.3Ca} \right)^{\frac{1}{3}}$$

If you need to produce different numbers of coils as shown in the table above, please consult SHAC.

K: The rigid values in the size table

Size Table of SMA Ball Screw

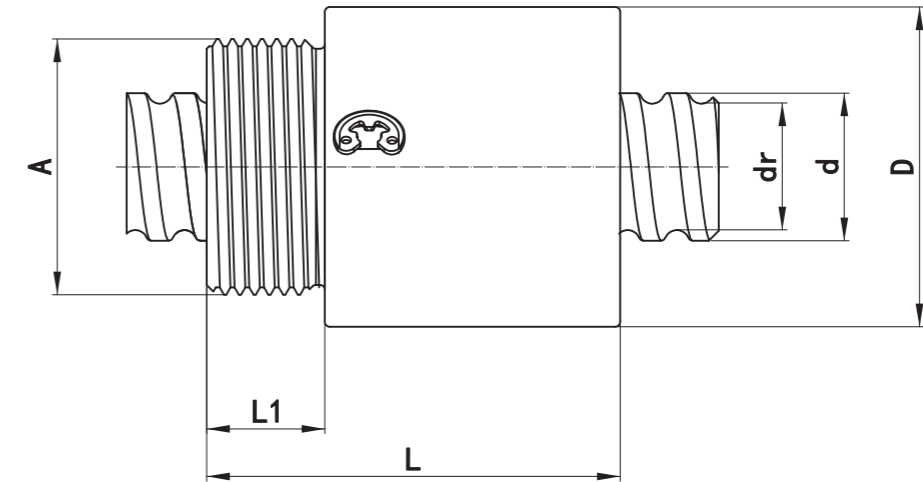

Model no.	d	l	Da	dr	Load Rating Ca(kgf)	Load Rating Co(kgf)	K kgf/μm	Dimension									
								D	L1	B	L	L2	H	A	Q	n	
SMAR1205-2.8	12	5	2.5	9.74	487	886	14	25.5	6	10	39	10	24	M20*1	M4	1.8*1	
SMAR1210-1.8		10			323	556	8				39.5						1.8*1
SMAR1220-1.8		20			313	578	8				58						1.8*1
SMAR1605-3.8	14.8	5	2.778	12.83	821	1706	22	32.5	7	10	42	12	30	M26*1.5	M4	3.8*1	
SMAR1610-2.8		10			643	1311	17				52						2.8*1
SMAR1620-1.8		20			424	841	10				62						1.8*1

The stiffness values shown in the table represent the spring constants. Each constant is determined by applying a preload equivalent to 10% of the axial basic rated dynamic load (Ca) and then applying an axial load three times the preload amount, with the load and elastic deformation measured under these conditions.

These values do not include the stiffness values of the nut mounting section and related components; therefore, please consider 80% of the values in the table as a rough guideline.

If the actual preload load (Fa0) is not 0.1Ca, the stiffness value (Kn) can be calculated using the following formula.

$$K_N = K \left(\frac{Fa_0}{0.3Ca} \right)^{\frac{1}{3}}$$

If you need to produce different numbers of coils as shown in the table above, please consult SHAC.

K: The rigid values in the size table

6 Appendix

A) Screw specification inspection table

Table 7-1-1

Taiwan Dinghan Precision

Pre sales Service Inspection Form

SHAC Contact person:

Customer person:

Date of Contact:

Customer Name	Nature of demand				Urgent	Important	General
					Completion within 24 hours	Completion within 72 hours	Completion within one day
Product name	Ballscrew	Linear Guideway	KK Module	Other:			
Customer Needs	New design	Design changes	Brand replacement	Repeat Order	Other:		
Quotation number	Axial direction		Drawing No.	Product model			

(Drawing attach)

Key data of screw drawing

A.	Load	B.	
C.	Displacement velocity	D.	
E.	Acceleration	F.	
G.	Fixation methcd	H.	
I.	Positioning accuracy	J.	
K.	Slender ratio	L.	
M.	Shaft DN value	N.	
O.	Nut DN value	P.	
Q.	Service life	R.	
S.	Environmental vibration	T.	±E
U.	Operation impact	V.	T+E
W.	Environmental gas	X.	e300
Y.	Lubrication type	Z.	e

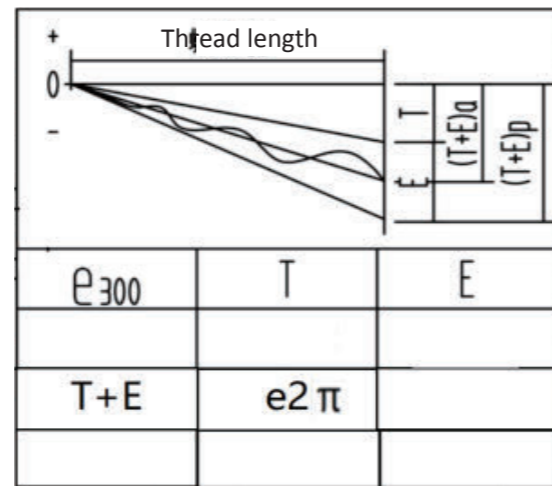

B) Base axis tolerance table

Table 7-1-2

Unit: mm

Diameter(mm)	a		c		d		e		f		g		h						js		j		k		m		n		p		r	
	about	below	a13	c12	d6	d6	e6	f6	f5	f6	g5	g6	h5	h6	h7	h8	h9	h10	js5	js6	j5	j6	k5	k6	m5	m6	n5	n6	p5	p6	r6	r7
3		6	-270	-450	-30	-38	-20	-28	-15	-18	-4	-12	0	-8	0	-12	0	0	±2.5	±4	+3	+6	+6	+9	+9	+12	+13	+16	+17	+20	+23	+27
6		10	-280	-500	-40	-49	-25	-34	-19	-22	-5	-14	0	-9	0	-15	0	0	±3	±4.5	+4	+7	+10	+12	+16	+19	+21	+24	+28	+34	+41	
10		14	-290	-560	-50	-61	-32	-43	-20	-27	-6	-17	0	-11	0	-18	0	0	±4	±5.5	+5	+8	+12	+15	+20	+23	+26	+29	+34	+41	+49	
14		18	-300	-630	-65	-78	-40	-53	-29	-33	-7	-20	0	-13	0	-21	0	0	±4.5	±6.5	+5	+9	+11	+15	+21	+24	+28	+31	+35	+41	+49	
18		24	-310	-700	-80	-96	-50	-66	-36	-41	-9	-25	0	-16	0	-25	0	0	±5.5	±8	+6	+11	+13	+18	+25	+28	+33	+37	+42	+50	+59	
24		30	-320	-770	-95	-110	-65	-83	-43	-49	-10	-29	0	-19	0	-33	0	0	±6.5	±9.5	+6	+12	+15	+21	+24	+30	+33	+39	+45	+51	+60	
30		40	-340	-800	-110	-130	-75	-96	-49	-58	-11	-33	0	-23	0	-39	0	0	±6.5	±9.5	+6	+12	+15	+21	+24	+30	+33	+39	+45	+51	+60	
40		50	-360	-820	-140	-170	-100	-120	-58	-68	-12	-36	0	-26	0	-46	0	0	±7.5	±11	+6	+13	+18	+25	+28	+35	+38	+45	+52	+59	+73	
50		65	-380	-820	-170	-200	-120	-142	-68	-79	-13	-40	0	-29	0	-54	0	0	±7.5	±11	+6	+13	+18	+25	+28	+35	+38	+45	+52	+59	+73	
65		80	-410	-820	-200	-240	-145	-170	-79	-94	-14	-43	0	-32	0	-63	0	0	±7.5	±11	+7	+14	+21	+28	+33	+40	+45	+52	+61	+68	+88	
80		100	-460	-820	-230	-270	-170	-200	-94	-110	-15	-46	0	-35	0	-74	0	0	±7.5	±11	+7	+14	+21	+28	+33	+40	+45	+52	+61	+68	+88	
100		120	-460	-820	-230	-270	-170	-200	-94	-110	-15	-46	0	-35	0	-74	0	0	±7.5	±11	+7	+14	+21	+28	+33	+40	+45	+52	+61	+68	+88	
120		140	-460	-820	-230	-270	-170	-200	-94	-110	-15	-46	0	-35	0	-74	0	0	±7.5	±11	+7	+14	+21	+28	+33	+40	+45	+52	+61	+68	+88	
140		160	-460	-820	-230	-270	-170	-200	-94	-110	-15	-46	0	-35	0	-74	0	0	±7.5	±11	+7	+14	+21	+28	+33	+40	+45	+52	+61	+68	+88	
160		180	-460	-820	-230	-270	-170	-200	-94	-110	-15	-46	0	-35	0	-74	0	0	±7.5	±11	+7	+14	+21	+28	+33	+40	+45	+52	+61	+68	+88	

SHAC

>>>

SHAC KK module



>>>

Preface

The ball screw and linear guide are ingeniously integrated to combine the advantages of both. The innovative U-shaped rail design, optimized through advanced finite element method structural stress analysis, achieves high rigidity with an optimal cross-section.

The two rows of Gothic-style circular rails with 45° contact angle deliver exceptional design that ensures high operational precision and four-directional equal load distribution.

The highly integrated design maximizes space efficiency while simplifying installation for customers, eliminating the need for complex adjustment processes.

(A) Product Structure

Lead Screw, Linear Guide, Base, Motor Base, Compact Module:

A product that integrates traditional ball screws and linear guides into the workbench base and combines them with a replaceable motor base.

Product Structure

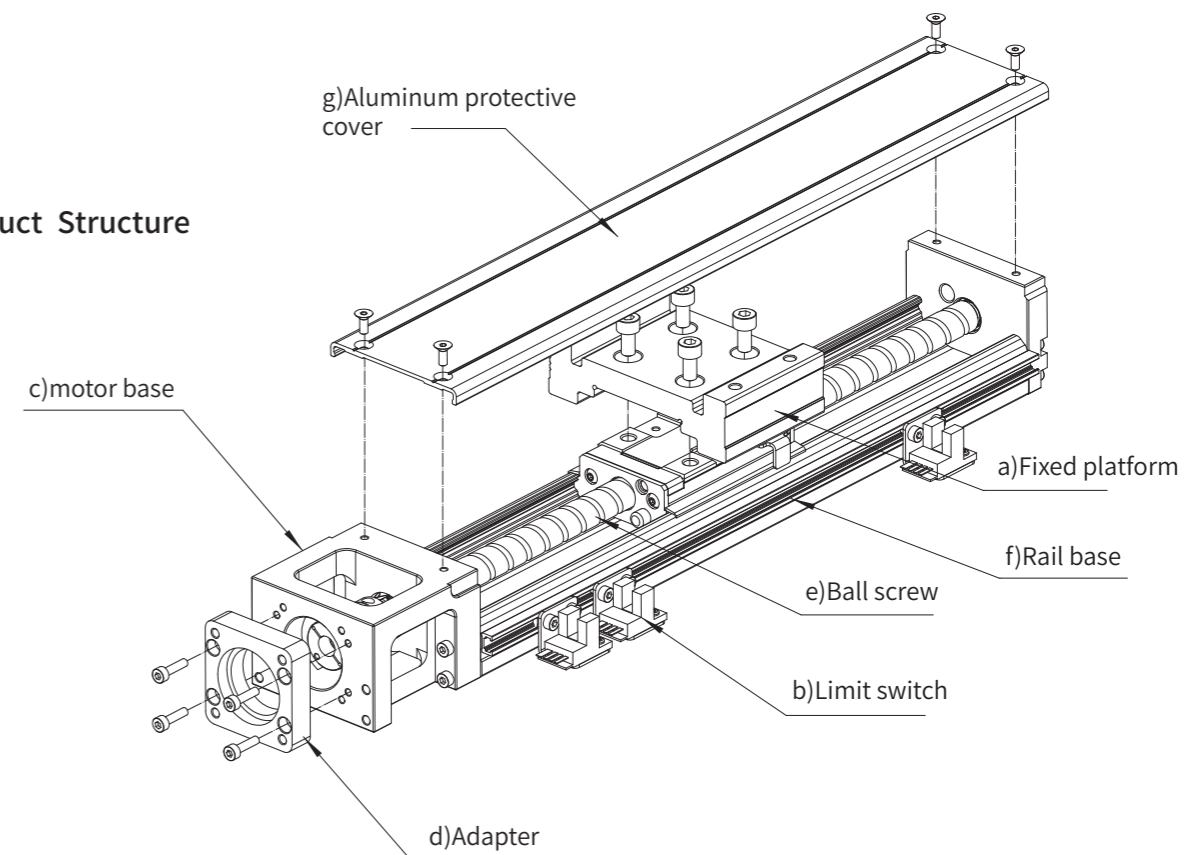

Figure 2-2-1

Integrating the ball screw nut with the linear rail slider into a single unit significantly reduces the spatial footprint of a single-axis mechanical structure. By combining traditional single-axis base with linear guide rails into an integrated configuration, the combination of these two breakthrough structures results in a novel single-axis mechanical product: SHAC Transmission's compact KK modular unit.

This modular unit combines standardized fixed platforms with screw/slider assemblies, achieving precise displacement through ball screw transmission.

An enclosure cover protects the transmission components against dust and contamination, while the standardized motor base allows flexible connection to various motor specifications via motor mounting flanges.

To meet automation requirements, SHAC Transmission's compact modular design incorporates flexibly settable limit switches that satisfy unmanned automatic control needs.

(B) Product Features

I. Multiple specifications, II. Simple assembly and maintenance, III. Customization, IV. Single to multi-axis combination application

SHAC KK compact module offers a wide range of specifications for selection

KK40:100,150,200

KK50:150,200,250,300

KK60:150,200,300,400,500,600

KK86:340,440,540,640,740,940

KK100:980,1080,1180,1280,1380

KK130:980,1180,1380,1680

II. Simple assembly and maintenance

KK module installation: ensure stable operation of the device

Want to make your device run smoother Installing the KK module correctly is the key!

1. Clean the surface

Before starting the installation, be sure to clean the burrs, dirt, and surface scratches off the mechanical installation surface. A clean surface is the foundation for ensuring stable operation of the module.

2. Choose the appropriate torque

Using a torque wrench, select the appropriate locking torque based on the platform material. Slowly tighten the slide rail positioning screws, ensuring that each one is properly tightened, but without applying excessive force.

3. Tighten the screws in order

Starting from the middle section of the slide rail, sweep towards both sides in order and tighten the slide rail positioning screws. This allows the rail to slightly adhere to the installation surface, achieving relatively stable accuracy. After slightly tightening on the reference surface, the lateral reference surface clamping force of the slide rail will be strengthened, so that the main rail can accurately adhere to the reference surface.

III. Customization

KK compact module offers a standard inventory of multiple specifications. For any special requirements, please contact Dinghan technical engineers

IV. It can be applied in single-axis or multi-axis combinations

KK compact module offers a variety of combination modes to meet various working conditions

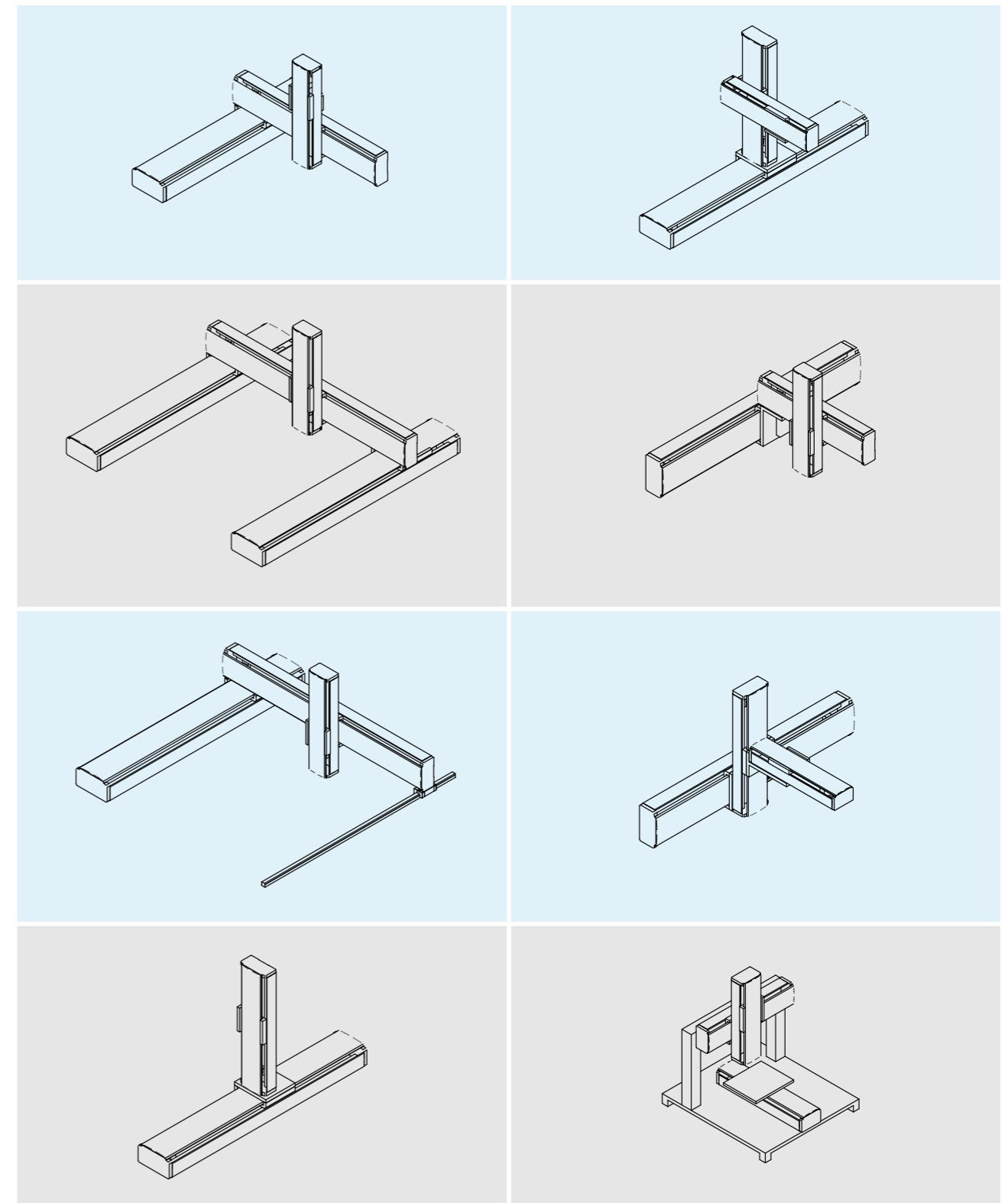

Figure 1-1-2

(C) Comprehensive comparison

a Structural Design and Integration Degree b Performance Differences c Maintenance and Cost

The core difference between KK module and traditional screw module lies in structural integration, precision performance, and maintenance cost. Here is a specific comparison:

1. Structural design and integration degree

1. KK module

Adopting an integrated design, the ball screw and linear guide are embedded in the main body and ground into shape, eliminating the need for independent guide rails and multiple sliders.

The slide seat serves as both the nut seat of the screw and the slider of the guide rail, with a compact structure and small installation area, suitable for space limited scenarios.

2. Traditional screw module

Assembled from independent ball screws, aluminum body, linear guide, and 4 sliders, requiring additional connectors and occupying more space.

2. Performance differences

1. Accuracy and rigidity

The KK module reduces assembly errors due to its integrated design, with a repeatability accuracy of $\pm 0.003\text{mm}$, higher rigidity, and strong load stability.

The traditional screw module is susceptible to assembly errors due to the separate design of the guide rail and screw, resulting in relatively low accuracy and rigidity.

2. Friction and efficiency

The KK module achieves motion through ball rolling, with a low coefficient of friction, a running speed of up to 0.5m/s , acceleration of up to 9m/s^2 , low noise, and low energy consumption.

Traditional screw modules are prone to wear and heat generation due to high sliding friction, which affects long-term efficiency and lifespan.

3. Maintenance and Cost

1. Maintain complexity

The KK module has good sealing, is not prone to dust accumulation, and is easy to maintain.

The traditional screw module requires regular cleaning and lubrication of the guide rail, with a high maintenance frequency.

2. Cost effectiveness

The initial cost of KK module is relatively high, but the long-term failure rate is low, and the comprehensive use cost is better.

Traditional screw module has lower cost and is suitable for scenarios with limited budget but low precision requirements.

If you need to further understand related technologies, you can explore single axis robotic arms, linear module selection, or ball screw optimization design.

(D) Product Application

Various devices

The compact KK module is widely used in high-precision applications due to its compact structure and high precision

The product has powerful functions and complete specifications, suitable for various automation industries



Lithium battery industry



equipment automation



3C industry

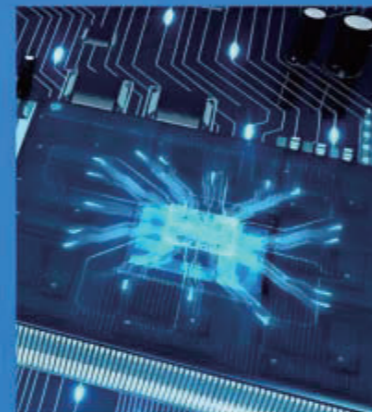

semiconductor industry



photovoltaic industry



medical industry



welding industry



industrial robots



automotive industry

(E) Selection steps

4 principles, 8 key points

When selecting KK modules, we need to follow a series of basic principles to ensure that the selected modules not only have outstanding cost-effectiveness, but also meet the actual needs of mechanical work. These principles include: clear application requirements, evaluation of module performance, emphasis on brand and service, and reasonable budget planning.

By following these 4 principles, you will be able to easily select the KK module that best suits you.

- ① Performance first, price second: At the beginning of design, the module should be considered first to ensure that it can meet the requirements of mechanical products, and then seek suppliers with high cost-effectiveness.
- ② Type selection is more important than brand: When selecting, different models of products should be flexibly chosen according to actual needs in different occasions and opportunities.
- ③ Continuous supply capability cannot be ignored: When choosing, attention should be paid attention to the stability of the brand's supply, rather than single orders or non-standard specifications.
- ④ Standard models are preferred: In non essential situations, it is recommended to avoid selecting special specifications to ensure smooth ordering, delivery, and maintenance processes.

Mastering these 8 key selection points will help you with module selection and provide strong support for your mechanical work.

- ① Usage conditions
 - Effective travel
 - Space position restrictions (width, height, length)
 - Installation methods (horizontal, vertical, side hanging)
 - Load center of gravity position
 - Operating conditions (lead, speed, acceleration/deceleration, working cycle)
 - Operating environment (high temperature, vibration, oil, water, corrosion)
- ② Accuracy requirements
 - Position accuracy
 - Reproducibility accuracy
 - Walking parallelism
- ③ Application form
 - Single axis
 - Dual axis
 - Multi axis
 - Special combination
- ④ Motor selection
 - AC servo motor
 - Stepper motor
 - With or without brakes
- ⑤ Motor load calculation
 - Maximum speed
 - Motor resolution
 - Motor torque calculation
- ⑥ Operation analysis
 - Acceleration
 - Actual operating mode (V-T diagram)
- ⑦ Other accessories
 - Selection of related accessories (limit switch, adapter plate, telescopic cover, electrical protective cover)
- ⑧ Final confirmation
 - Confirmation of usage conditions
 - Price and delivery time
 - Additional processing
 - Special requirements

(F) key technology

◎ Precision speed motor calculation

A) Analysis of Motor Speed Control Accuracy

I) Definition and Calculation Method

The precision of motor speed control refers to the degree of deviation between the actual speed and the set speed, usually expressed as a percentage. The calculation formula is:

Speed regulation accuracy = $\frac{(\text{actual speed} - \text{set speed})}{\text{set speed}} \times 100\%$. The lower the value, the more precise the speed control.

II) Core factors affecting accuracy

1. Hardware performance

Motors and Drivers: High performance servo motors (such as servo drives that support 0.02mm positioning accuracy) and matching drivers can significantly reduce errors.

Sensor accuracy: The acquisition accuracy of sensors such as encoders or Hall elements directly affects the accuracy of speed feedback.

2. Control Strategy

Control algorithm: The use of PI/PID controller (proportional integral derivative) can effectively regulate dynamic response and steady-state error. For example, the integral term is used to eliminate steady-state errors, while the proportional term improves response speed.

Closed loop control: By adjusting the output in real-time feedback, it avoids step loss or accumulated errors in open-loop control.

3. External interference

Power fluctuations, temperature changes, and sudden changes in mechanical loads can all cause speed fluctuations. Interference needs to be reduced through filtering circuits, environmental isolation, and other means.

III) Key technologies for improving speed accuracy

1. Parameter tuning

Optimize PID parameters (such as proportional gain Kp, integration time Ki) through trial and error, Ziegler Nichols method, or automatic tuning algorithm.

Adopting adaptive control or sliding mode control (SMC) to adapt to load changes and enhance robustness.

2. High frequency response system

Increase the control cycle frequency (such as shortening the PWM cycle) to ensure fast response to speed commands.

Reduce signal transmission delay by using high-speed communication protocols such as EtherCAT.

3. System calibration and maintenance

Regularly calibrate sensors and drivers to ensure long-term stability during operation.

IV) Accuracy differences among different motors

Motor Type	typical precision range	Applicable scenarios
Stepper motor	$\pm 5\% - \pm 10\%$	low-cost, medium to low precision requirements (such as 3D printing)
Ordinary servo motor	$\pm 0.1\% - \pm 1\%$	Industrial robots, CNC machine tools
High precision servo motor	$\pm 0.02\% - \pm 0.1\%$	Semiconductor manufacturing, precision medical equipment

V) Typical application scenarios

Industrial automation: The conveyor belt of the production line needs to adjust its speed dynamically according to the load, and the PID algorithm can maintain an accuracy within $\pm 20\text{rpm}$.

Medical equipment: The centrifuge requires a speed error of less than $\pm 0.5\%$, which necessitates the integration of closed-loop control and temperature compensation.

Robot technology: Joint motors need to achieve multi-axis coordination with a positioning accuracy of 0.02mm, relying on servo drives and model predictive control (MPC).

VI) Future Trends

AI-optimized algorithms: Employ machine learning to dynamically adjust control parameters and adapt to complex operating conditions.

Integrated design: Drivers, controllers, and sensors are highly integrated to minimize signal loss and interference.

(Notes: The above combines servo systems, control algorithms, and practical cases; specific implementation must be tailored to motor types and system requirements.)

B) Analysis of the Relationship between Motor Speed Control Accuracy and Load

I) The direct impact of load on speed control accuracy

◎The increase in load leads to a decrease in speed and fluctuations in precision

When the load increases, the motor requires greater torque output to maintain speed. If the control system cannot compensate for load variations in real-time, the actual rotational speed will deviate from the set value, resulting in reduced accuracy. For example, in permanent magnet synchronous motors, speed dynamically decreases under increased load and requires closed-loop control to adjust current and voltage for speed stabilization.

- Stepper motor: If the load torque exceeds its holding torque, there will be a loss of step, resulting in speed loss of control.

- Servo motor: Through high-precision encoder feedback and PID algorithm, it can achieve speed control accuracy within $\pm 0.1\%$, even if the load fluctuates.

◎Dynamic errors caused by sudden load changes

The instantaneous change of mechanical load (such as sudden increase or decrease of materials on the production line) can cause a delay in the inertia response of the motor, resulting in short-term speed deviation. At this point, it is necessary to increase the response frequency of the control system or adopt sliding mode control (SMC) to enhance its anti-interference ability.

II) Differences in load adaptability of different types of motors

Motor Type	Load sensitivity	Typical control accuracy range
stepper motor	High (dependent on constant load)	$\pm 5\% - \pm 10\%$
Ordinary servo motor	Medium low (closed-loop compensation)	$\pm 0.1\% - \pm 1\%$
Permanent magnet synchronous motor	Low (requires support for variable frequency speed regulation)	$\pm 0.02\% - \pm 0.5\%$

Stepper motor: prone to step loss during load changes, only suitable for light and stable scenarios (such as 3D printers).

Servo motor: By adjusting the current output through real-time feedback, it can adapt to speed control within the range of 20% -150% rated load.

(G) Instructions for Use

◎Installation ◎ lifespan ◎maintenance

KK Compact module installation, lifespan, and maintenance

Based on relevant technical specifications and usage requirements, the following are key points summarized:

1、 Installation points

Surface cleaning

Before installation, it is necessary to thoroughly clean the mechanical surface of burrs, dirt, and scratches to ensure a smooth installation surface and avoid module deformation or accuracy degradation caused by impurities.

Screw locking specifications

Use a torque wrench and select the appropriate locking torque based on the material (such as aluminum alloy or steel) to avoid excessive tightening and deformation of the slide rail.

The tightening sequence should extend from the middle of the slide rail to both sides, ensuring that the rail is evenly attached to the installation surface and improving stability.

Centering and debugging

After installation, it is necessary to check the coaxiality between the screw and the motor shaft, and debug until there is no jamming or abnormal noise during the movement process to improve transmission efficiency.

2、 Factors affecting lifespan and maintenance measures

Oil lubrication:

Before the first use, use kerosene or organic solvents to remove the anti-corrosion oil inside the module, dry it and fill it with lithium soap based grease with a viscosity grade of N0.2; Regular supplementation will be carried out in the future to reduce friction losses.

Oil lubrication: If lubricating oil is used, ISO viscosity grade VG15-100 oil can be directly used, and the model can be adjusted according to the working temperature, and injected into the shaft through the oil supply pipe or bearing seat oil hole.

Dust prevention and cleaning

Regularly clean the dirt on the surface of the module and moving parts to prevent particles from entering the ball track or screw, which may cause increased wear.

Oil lubrication is not recommended for seal ring bearings as they may fail due to oil scraping.

Load and environment adaptation

Avoid overloading operation and match the screw diameter and pitch parameters of module models (such as CM compact module 6010 series) reasonably to ensure load capacity and stability.

In harsh environments such as high temperature and high dust, it is necessary to shorten the maintenance cycle and strengthen the lubrication frequency.

3、 Maintenance and testing

Accuracy testing

Regularly verify the positioning accuracy, walking parallelism, and starting torque to ensure that the module performance meets the design requirements of high rigidity and high precision.

Component inspection

Observe the wear of ball screws and U-shaped slides, and replace deformed or damaged components in a timely manner.

Check if the lubrication system oil circuit is unobstructed to avoid dry friction caused by insufficient oil supply.

summary

The lifespan of KK compact modules is closely related to installation standards and maintenance frequency. By reasonable lubrication, dust-proof cleaning, load control, and regular testing, its service life can be significantly extended (usually up to several years to ten years, depending on the operating conditions), and high-precision and high-efficiency operation can be maintained.

(H) Related matters

Precautions for personal safety, storage, installation, operation, use, and maintenance

KK Compact Module Precautions and Safety Operating Procedures

1、 Personal safety precautions

Operating qualifications and training

Operators need to hold relevant qualification certificates, receive regular safety training, and be familiar with equipment structure, performance, and emergency response procedures.

During work, it is necessary to concentrate throughout the entire process and prohibit unrelated activities. Protective equipment must be worn for high-temperature or high-altitude operations.

Check before starting the device

Verify that the electrical system, braking devices, and safety limit switches (such as photoelectric switches) are functioning properly to avoid accidents caused by voltage fluctuations or circuit abnormalities.

Check the lifting equipment, load weight, and center of gravity to ensure that they are within the rated load range of the module, and overloading is strictly prohibited.

II) Storage and installation specifications

Storage environment requirements

The storage environment should be dry and free of corrosive gases, avoiding moisture and oxidation of magnetic templates or precision components.

During long-term storage, it is necessary to regularly check the condition of the anti-corrosion oil and supplement or replace it if necessary.

Installation steps and details

Surface treatment: Thoroughly clean the mechanical surface of burrs, dirt, and anti-corrosion oil before installation to ensure a smooth and undamaged contact surface.

Screw locking: Use a torque wrench to tighten the screws in the middle to both sides in sequence. The recommended torque for aluminum alloy materials is $\leq 5\text{N} \cdot \text{m}$ to avoid deformation of the slide rail.

Centering and debugging: calibrate the coaxiality of the lead screw and the motor shaft to ensure that the movement is free of stagnation and reduce the risk of abnormal wear.

III) Operation and usage standards

Operation control: After starting, a no-load test run is required to confirm that the lubrication system is supplying oil normally before gradually loading.

Avoid emergency stops, sudden turns, or frequent starts and stops. After high-speed full load operation, run without load for 5-10 minutes to dissipate heat.

Photoelectric switch management: Set starting and limit switches, reserve a safe distance (recommended $\geq 20\text{mm}$) to ensure effective emergency braking.

The photoelectric switch power supply needs to be independently powered and should not be shared with the motor driver to prevent damage to the circuit caused by reverse electromotive force.

IV) Key points of maintenance and upkeep

Lubrication management

Oil lubrication: Remove the anti-corrosion oil before first use and fill with N0.2 lithium soap based grease; Run every 100km or replenish once a month.

Oil lubrication: Select ISO VG15-100 lubricating oil and inject it through oil holes or oil pipes to avoid using oil lubrication for the sealing ring bearings.

Cleaning and dust prevention

Regularly clean the surface particles of ball screws and sliding rails. If the sealing structure is damaged, it needs to be replaced immediately.

Increase cleaning frequency in dusty environments and install dust covers if necessary.

Regular testing and replacement

Quarterly testing of positioning accuracy, walking parallelism, and starting torque, with calibration deviation $\geq 0.1\text{mm}$ requiring maintenance.

Check the wear of the ball screw and U-shaped slide rail, and replace them if there is local deformation or corrosion exceeding the limit.

(I) KK Compact Module Product Model

KK Compact Module Series (Ready Stock Quick Customization)

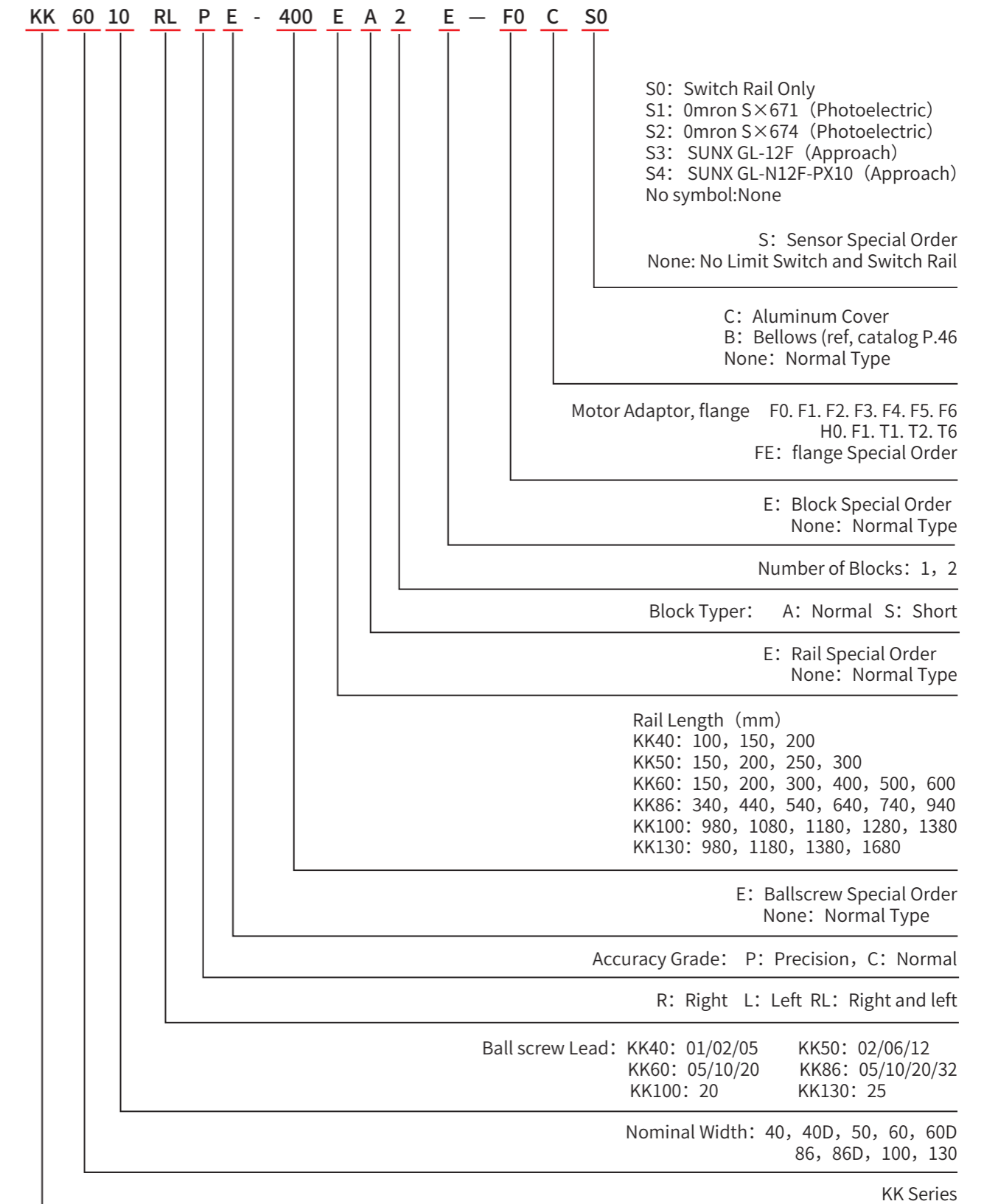

(J) Maximum speed

Model	Dia.	Ball screw Lead(mm)	Rail Length (mm)	Speed (mm/sec)	
				Precision	Normal
KK40/ KK40D	8	01	100	100	100
			150	100	100
			200	100	100
		02	100	200	200
			150	200	200
			200	200	200
		05	100	500	500
			150	500	500
			200	500	500
KK50	8	02	150	200	200
			200	200	200
			250	200	200
			300	200	200
	10	06	150	600	480
			200	600	480
			250	600	480
			300	600	480
		12	150	1200	960
			200	1200	960
			250	1200	960
			300	1200	960
KK60/ KK60D	12	05	150	500	400
			200	500	400
			300	500	400
			400	500	400
			500	490	390
			600	340	270
		10	150	1000	800
			200	1000	800
			300	1000	800
			400	1000	800
			500	980	780
			600	680	540
	20	150	1500	1200	
		200	1500	1200	
		300	1500	1200	
		400	1500	1200	
		500	1500	1200	
		600	1360	1000	

Model	Nominal Dia.	Ball screw Lead (mm)	Rail Length (mm)	Speed (mm/sec)	
				Precision	Normal
KK86/ KK86D	15	5	340	500	400
			440	500	400
			540	500	400
			640	390	310
			740	290	230
			940	180	140
			340	1000	800
			440	1000	800
			540	1000	800
		640	780	620	
		740	580	460	
		940	360	280	
		20	340	1500	1200
			440	1500	1200
			540	1500	1200
			640	1500	1200
			740	1150	920
			940	730	580
	16	32	340	2400	1920
			440	2400	1920
			540	2400	1920
			640	2400	1920
			740	2030	1620
			940	1250	1000
KK100	20	20	980	910	720
			1080	750	600
			1180	630	500
			1280	530	420
			1380	460	360
			980	1500	1200
KK130	25	25	1180	1000	800
			1380	750	600
			1680	500	400

(K) Load specifications



Model		Ball screw				Basic Dynamic Load Rating(N)												
		Nominal Dia. (mm)	Lead (mm)	Basic Dynamic Load (N)	Basic Static Load (N)	Block A		Block S										
						Block A	Block S	Block A	Block S									
KK4001	Precision	8	01	1585	3950	3920	-	6468	-									
	Normal			1211	2846													
KK4002	Precision		02	2784	5992													
	Normal			2128	4318													
KK4005	Precision		05	1374	2657													
	Normal			1050	1914													
KK5002	Precision		8	02	2784					5992	8007	-	12916	-				
	Normal				2128					4318								
KK5006	Precision	10	06	3165	6557													
	Normal			2419	4725													
KK5012	Precision		12	2104	4224													
	Normal			1609	3044													
KK6005	Precision	12	05	6239	12047	13230	7173	21462	11574									
	Normal			4769	8681													
KK6010	Precision		10	6047	11760													
	Normal			4622	8474													
KK6020	Precision		20	4018	7860													
	Normal			3071	5664													
KK8605	Precision		15	05	10522					23198					31458	-	50674	-
	Normal				8042					16716								
KK8610	Precision	10		8242	17827													
	Normal			6300	12846													
KK8620	Precision	20		5432	11437													
	Normal			4152	8241													
KK8632	Precision	16		32	5100	11440												
	Normal				3899	8243												
KK10020	Precision	20	20	7508	17205	39200	-	63406	-									
	Normal			5738	12397													
KK13025	Precision	25	25	8266	21572	48101	-	84829	-									
	Normal			6318	15544													

Model		Guideway											
		M_P (N-m)				M_R (N-m)				M_Y (N-m)			
		Block A1	Block A2	Block S1	Block S2	Block A1	Block A2	Block S1	Block S2	Block A1	Block A2	Block S1	Block S2
KK4001	Precision	33	182	-	-	33	182	-	-	81	162	-	-
	Normal												
KK4002	Precision	33	182	-	-	33	182	-	-	81	162	-	-
	Normal												
KK4005	Precision	33	182	-	-	33	182	-	-	81	162	-	-
	Normal												
KK5002	Precision	116	278	-	-	116	278	-	-	222	444	-	-
	Normal												
KK5006	Precision	116	278	-	-	116	278	-	-	222	444	-	-
	Normal												
KK5012	Precision	116	278	-	-	116	278	-	-	222	444	-	-
	Normal												
KK6005	Precision	152	348	72	205	152	348	72	205	419	838	241	482
	Normal												
KK6010	Precision	152	348	72	205	152	348	72	205	419	838	241	482
	Normal												
KK6020	Precision	152	348	72	205	152	348	72	205	419	838	241	482
	Normal												
KK8605	Precision	622	3050	-	-	622	3050	-	-	1507	3014	-	-
	Normal												
KK8610	Precision	622	3050	-	-	622	3050	-	-	1507	3014	-	-
	Normal												
KK8620	Precision	622	3050	-	-	622	3050	-	-	1507	3014	-	-
	Normal												
KK8632	Precision	622	3050	-	-	622	3050	-	-	1507	3014	-	-
	Normal												
KK10020	Precision	960	4763	-	-	960	4763	-	-	2205	4410	-	-
	Normal												
KK13025	Precision	1536	7350	-	-	1536	7350	-	-	3885	7770	-	-
	Normal												

(L) Accuracy grade

Model	Rail Length	Repeatability		Accuracy		Running Parallelism		Starting Torque (N-cm)				
		Precision	Normal	Precision	Normal	Precision	Normal	Precision	Normal			
KK40	100	±0.003	±0.01	0.02	-	0.01	-	1.2	0.8			
	150											
	200											
KK50	150	±0.003	±0.01	0.02	-	0.01	-	4	2			
	200											
	250											
	300											
KK60	150	±0.003	±0.01	0.02	-	0.01	-	15	7			
	200											
	300											
	400											
	500	±0.003	±0.01	0.025	-	0.015	-	15	7			
	600											
KK86	340	±0.003	±0.01	0.025	-	0.15	-	15	10			
	440											
	540											
	640											
	740	±0.003	±0.01	0.03	-	0.02	-	17	10			
	940											
	940											
KK100	980	±0.005	±0.01	0.035	-	0.025	-	17	12			
	1080											
	1180	±0.005	±0.01	0.04	-	0.03	-	20	12			
	1280											
	1380											
KK130	980	±0.005	±0.01	0.035	-	0.025	-	25	15			
	1180											
	1380			0.04						0.03	25	15
	1680											

Motor and connection flange

Motor No.	Model	KK40	KK50	KK60	KK86	KK100	KK130	
AC servo moto	Panasonic	MSM3AZ (30W)	F2	F2	F2	F3		
		MSM5AZ (50W)						
		MSM01 (100W)						
		MSM02 (200W)			F1			
		MSM04 (400W)						
		MSM08 (750W)				F4	F2	F4
	Mitsubishi	HP-PQ033 (30W)	F1	F1	F1	F2		
		HC-PQ053 (50W)						
		HC-PQ13 (100W)						
		HC-KFS053 (50W)	F1	F1	F1	F2		
		HC-KFS13 (100W)						
		HC-KFS23 (200W)				F0	F0	F1
	HC-KFS43 (400W)					F1	F2	
	Yaskawa	SGMAH-A3 (30W)		F1	F1	F2		
		SGMAH-A5 (50W)						
		SGMAH-01 (100W)				F0	F0	F1
		SGMPH-01 (100W)						
		SGMAH-02 (200W)						
		SGMAH-04 (400W)						
		SGMPH-02 (200W)						F0
SGMPH-04 (400W)								
SGMAH-08 (750W)					F1	F2		
Stepping motor	Nema17	F3	F3	F5				
	Nema23		(F-E2)	F4	F6			
	Nema34					F4		
	VEXTA	PK24	F3	F3	F5			
		PK26		(F-E2)	F4	F6		
		PK29					F4	F3
		PK54		F3	F5			
PK56			(F-E1)		F5			
PK59					F3			

KK60D Motor Adaptor Flange

KK60D F0

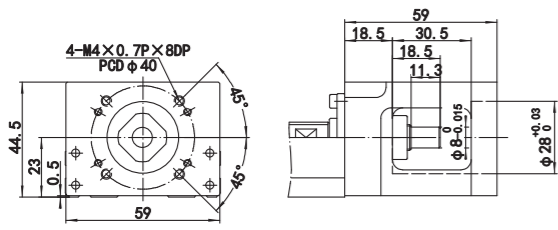

KK60D F1

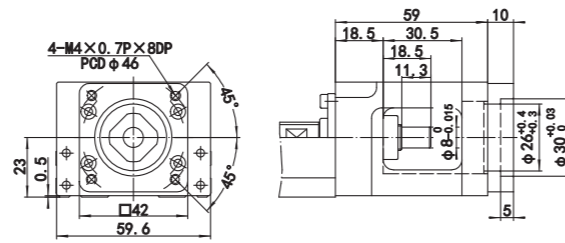

KK60D F2

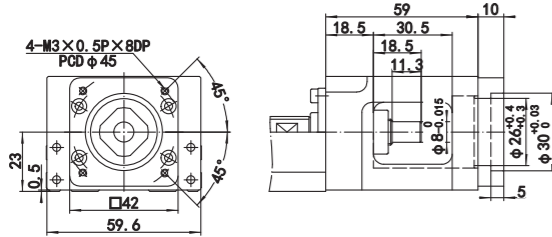

KK60D F3

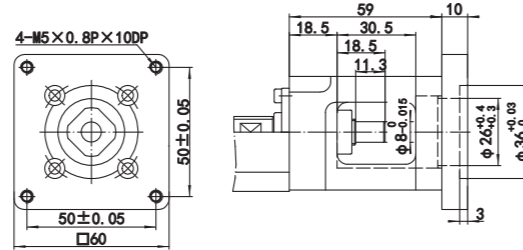

KK60D F4

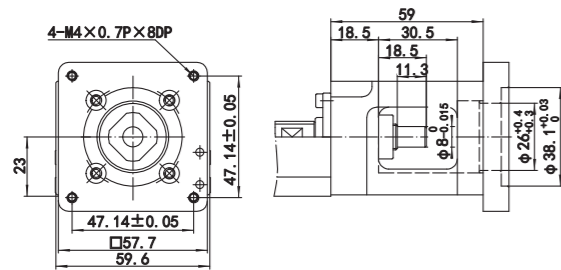

KK60D F5

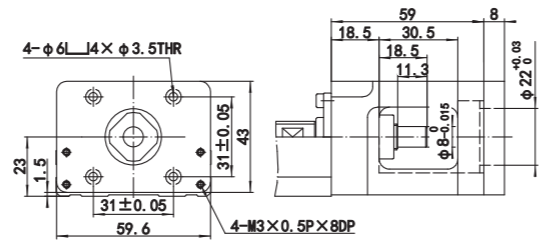

KK60D F6

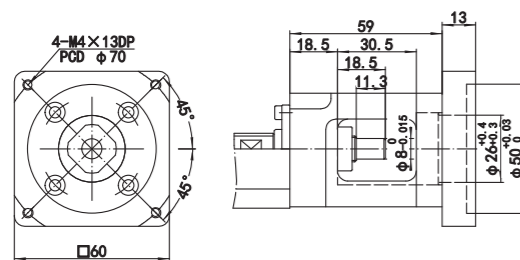

KK60D F7

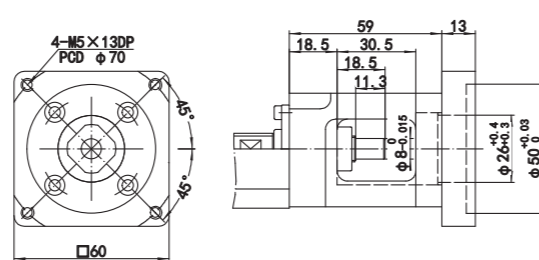

KK60D H0

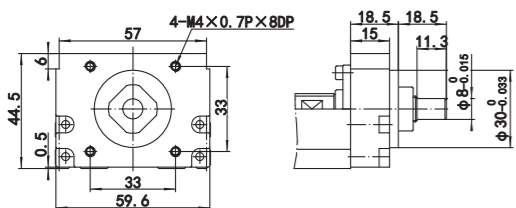

KK86 Motor Adaptor Flange

KK86 F0

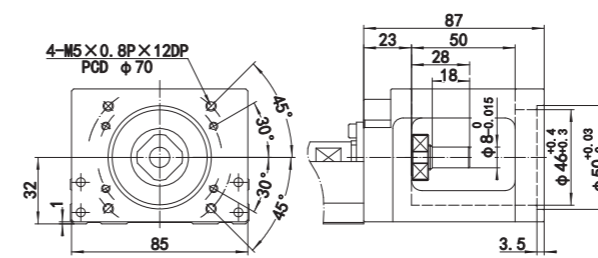

KK86 F1

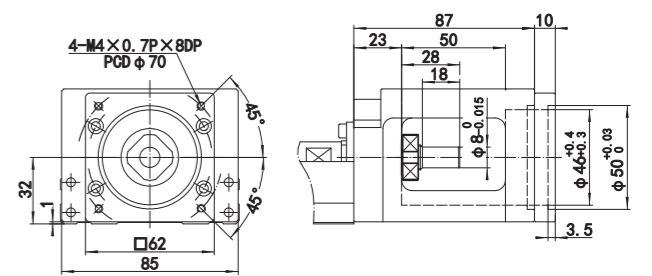

KK86 F2

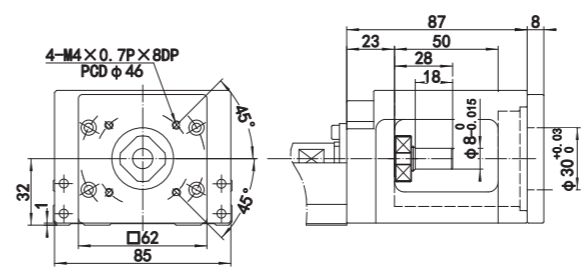

KK86 F3

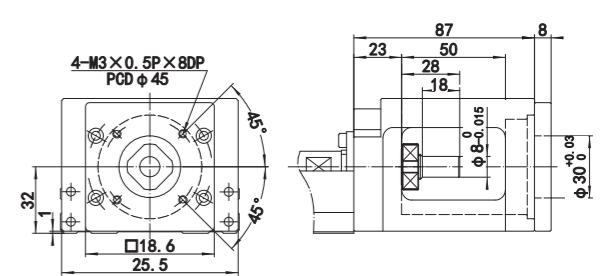

KK86 F4

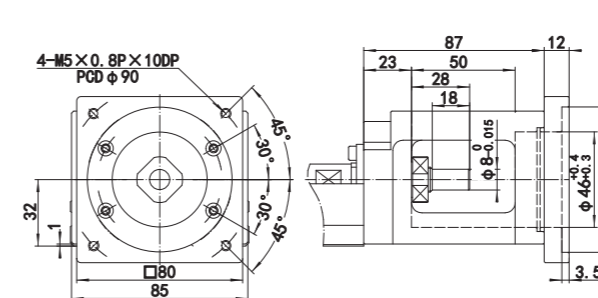

KK86 F5

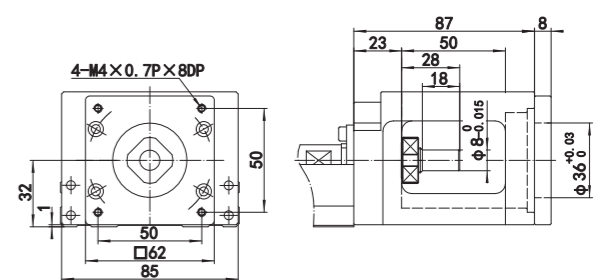

KK86 F6

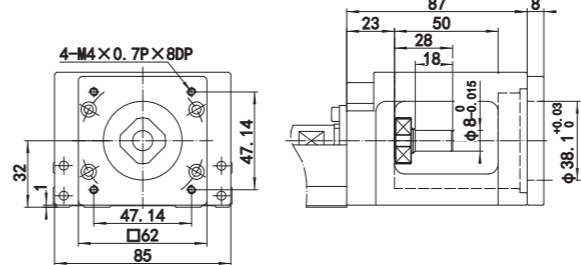

KK86 H0

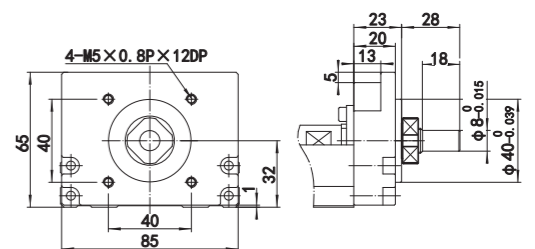

KK86D Motor Adaptor Flange

KK86D F0

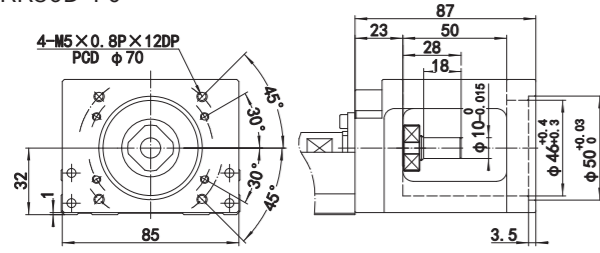

KK86D F1

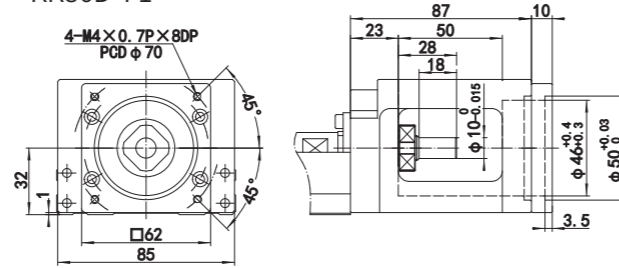

KK86D F2

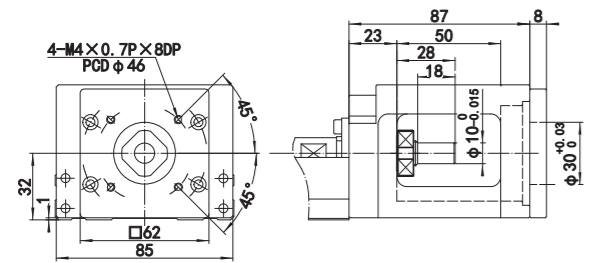

KK86D F3

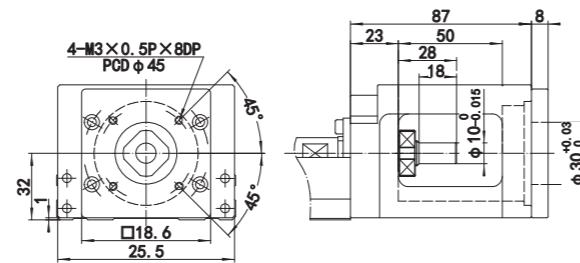

KK86D F4

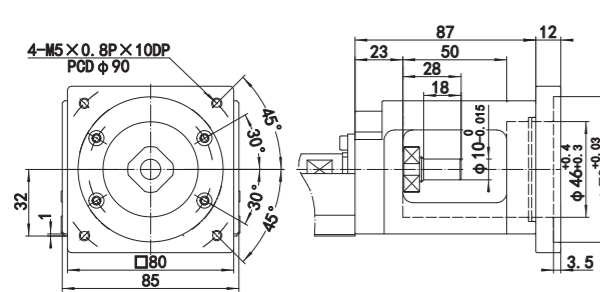

KK86D F5

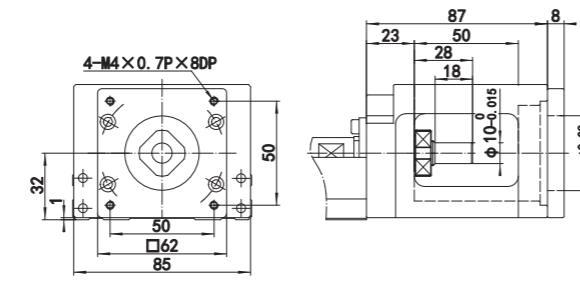

KK86D F6

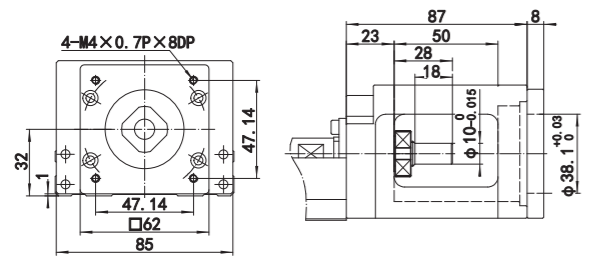

KK86D H0

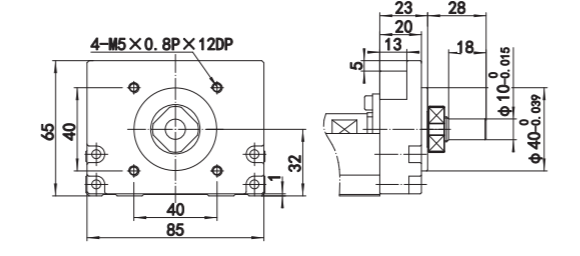

KK100 Motor Adaptor Flange

KK100 F0

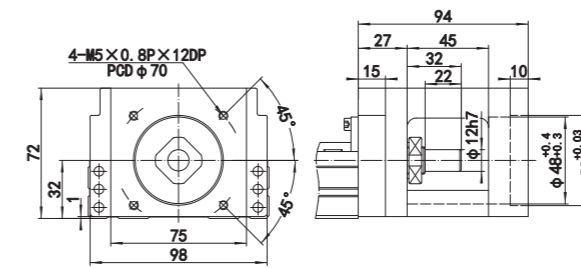

KK100 F1

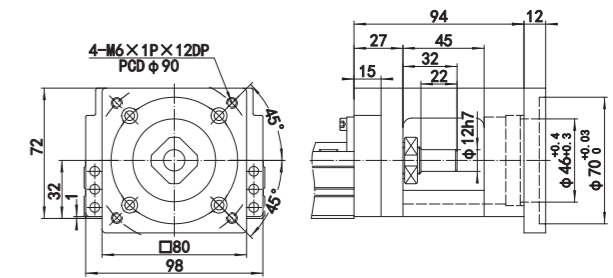

KK100 F2

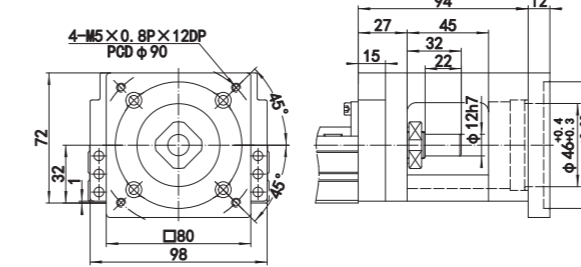

KK100 F3

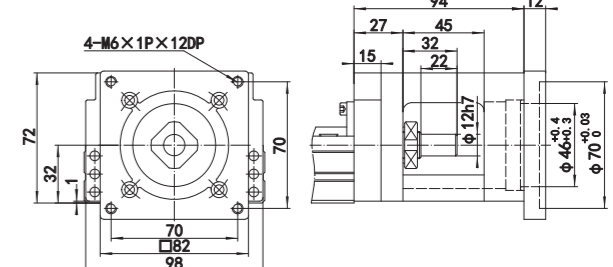

KK100 F4

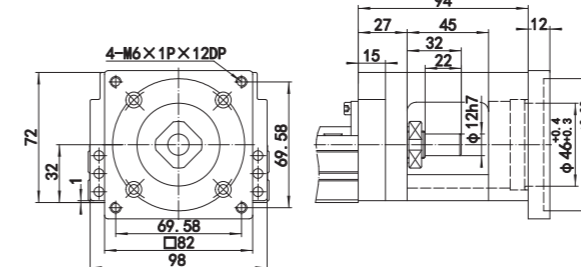

KK100 H0

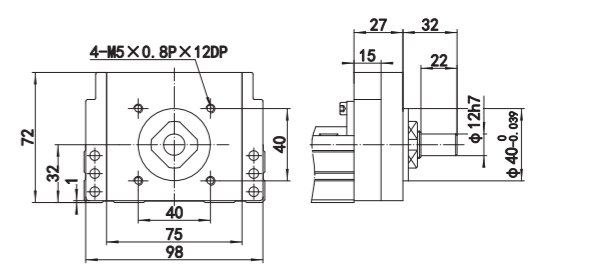

KK130 Motor Adaptor Flange

KK130 F0

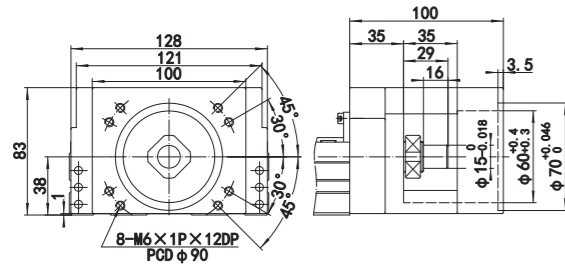

KK130 F1

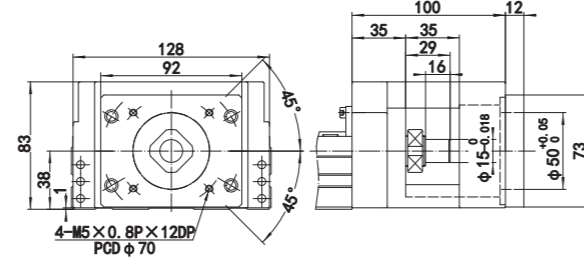

KK130 F2

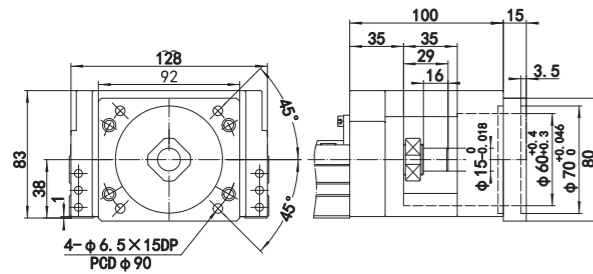

KK130 F3

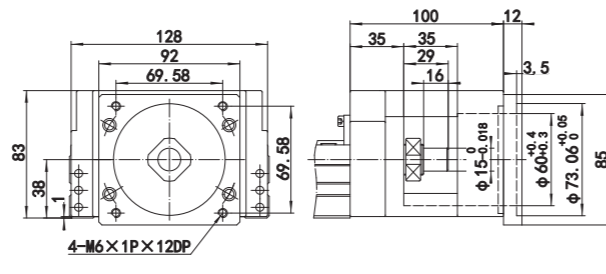

KK130 F4

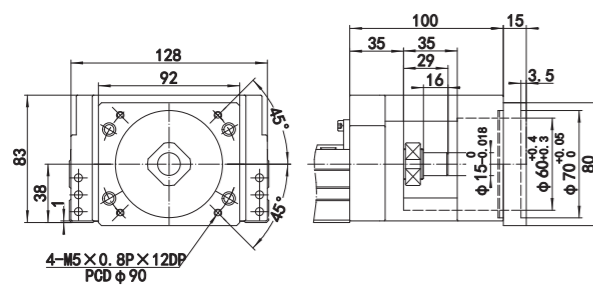

KK130 H0

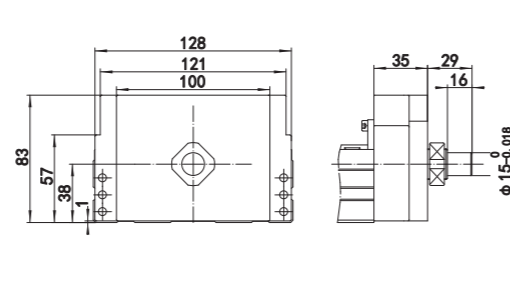

(N) Dinghan KK series KK40 (Excluding protective cover)

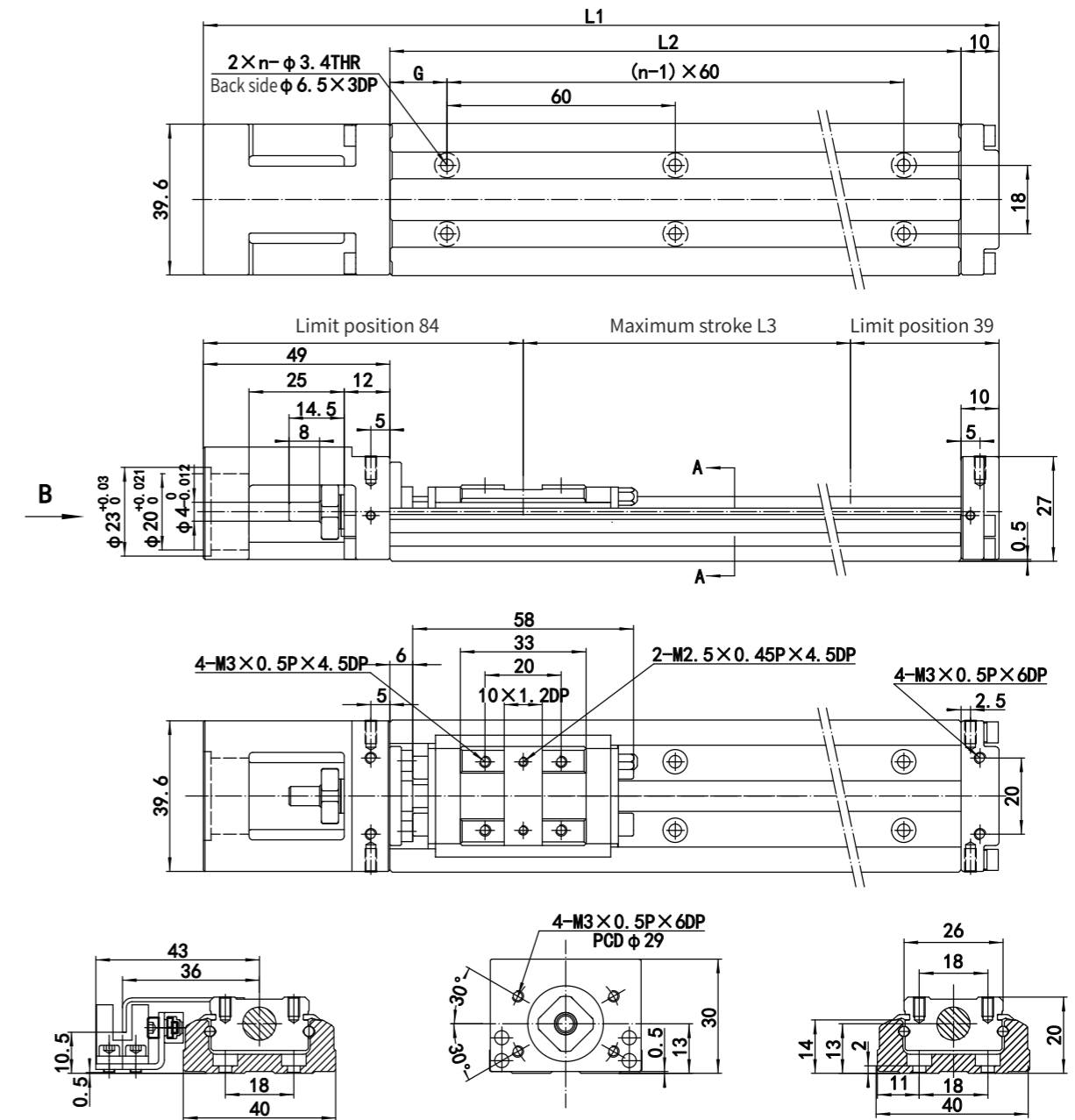

Photoelectric switch S2

B-direction motor fixing seat F0

A-A

Rail Length L2 (mm)	Total Length (mm)	Maximum Stroke (mm)		G (mm)	n	Mass (kg)	
		Block A1	Block A2			Block A1	Block A2
100	159	36	-	20	2	0.48	-
150	209	86	34	15	3	0.6	0.67
200	259	136	84	40	3	0.72	0.79

KK40D (Excluding protective cover)

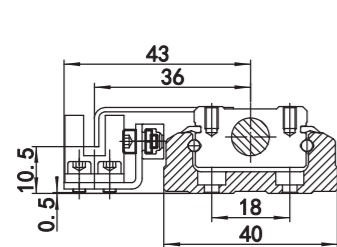
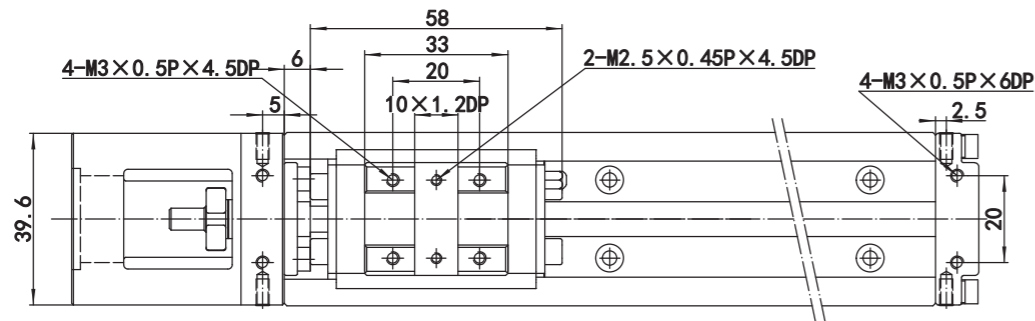
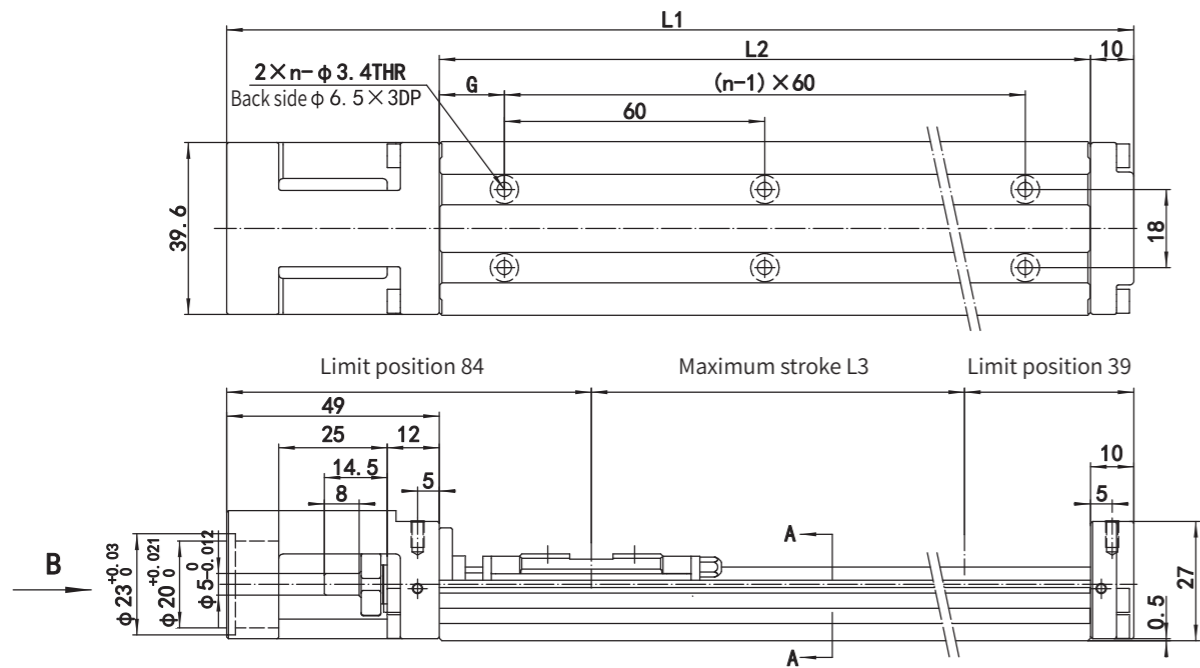

Photoelectric switch S2

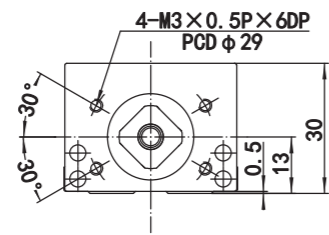

B-direction motor fixing seat F0

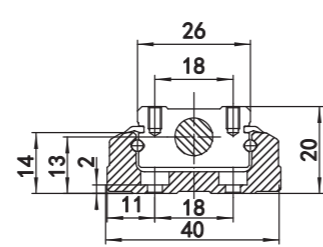

A-A

Rail Length L2 (mm)	Total Length (mm)	Maximum Stroke (mm)		G (mm)	n	Mass (kg)	
		Block A1	Block A2			Block A1	Block A2
100	159	36	-	20	2	0.48	-
150	209	86	34	15	3	0.6	0.67
200	259	136	84	40	3	0.72	0.79

KK50 (Excluding protective cover)

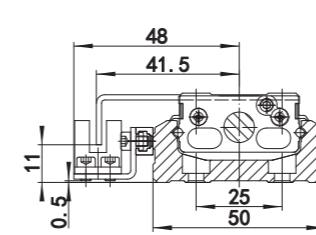
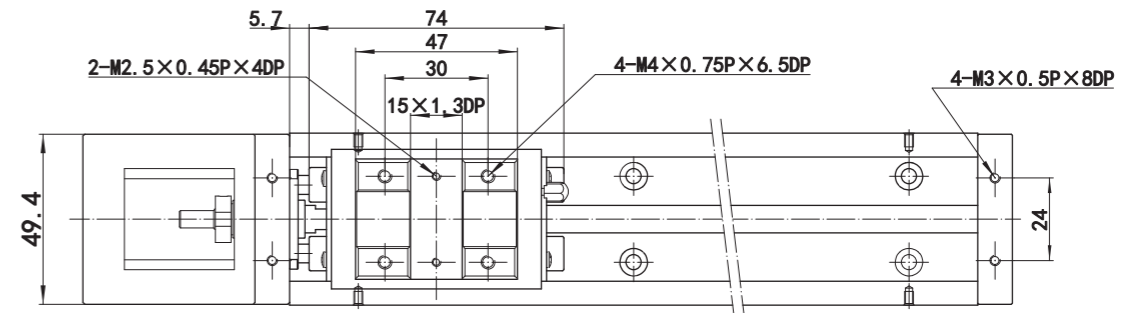
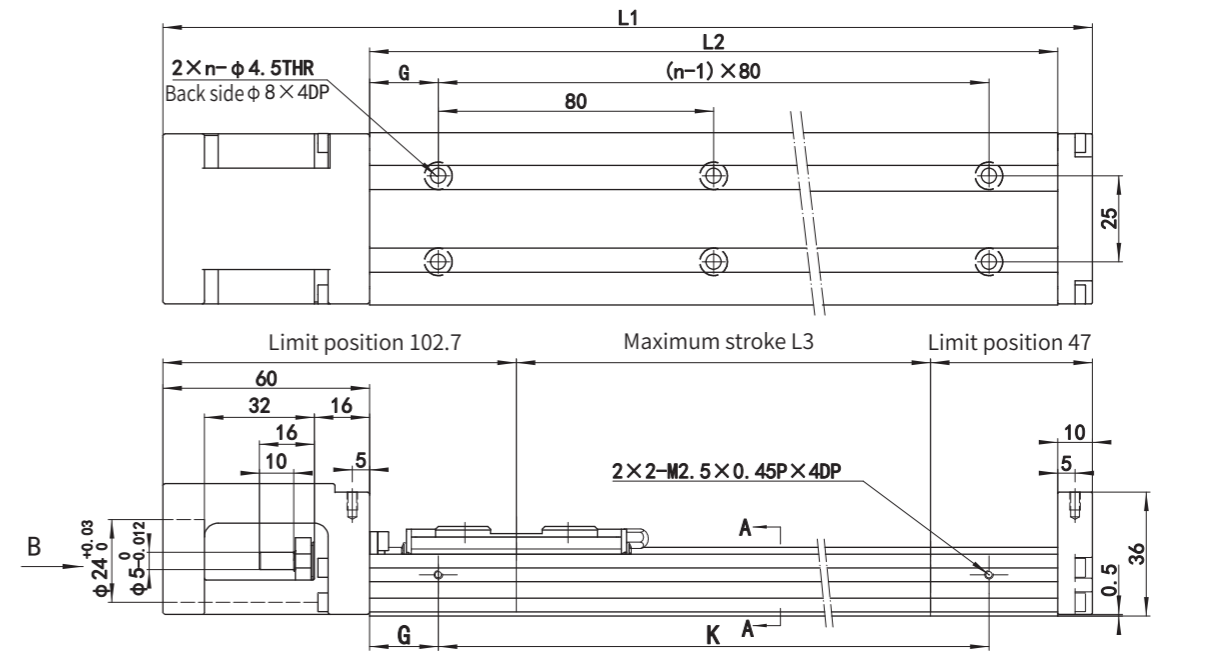

Photoelectric switch S2

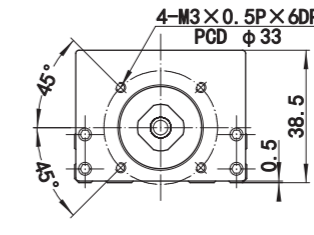

B-direction motor fixing seat F0

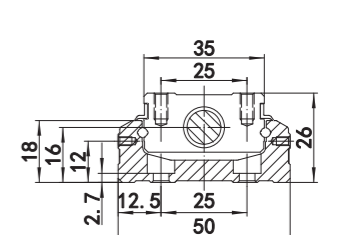

A-A

Rail Length L2 (mm)	Total Length (mm)	Maximum Stroke (mm)		G (mm)	K (mm)	n	Mass (kg)	
		Block A1	Block A2				Block A1	Block A2
150	220	70	-	35	80	2	1	-
200	270	120	55	20	160	3	1.2	1.4
250	320	170	105	45	160	3	1.4	1.6
300	370	220	150	30	240	4	1.6	1.8

KK60 (Excluding protective cover)

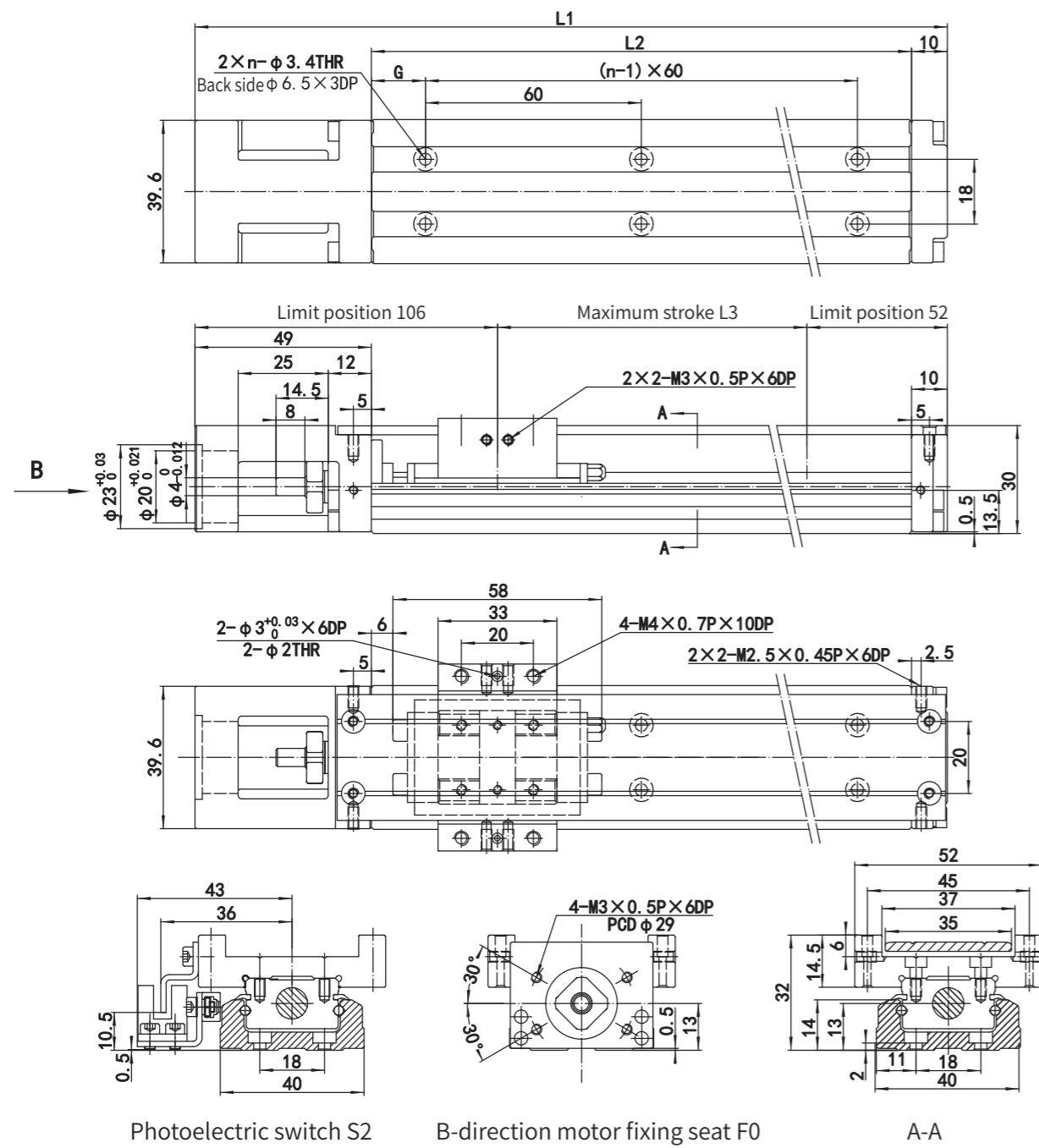

KK60 (Excluding protective cover \ Light load type)

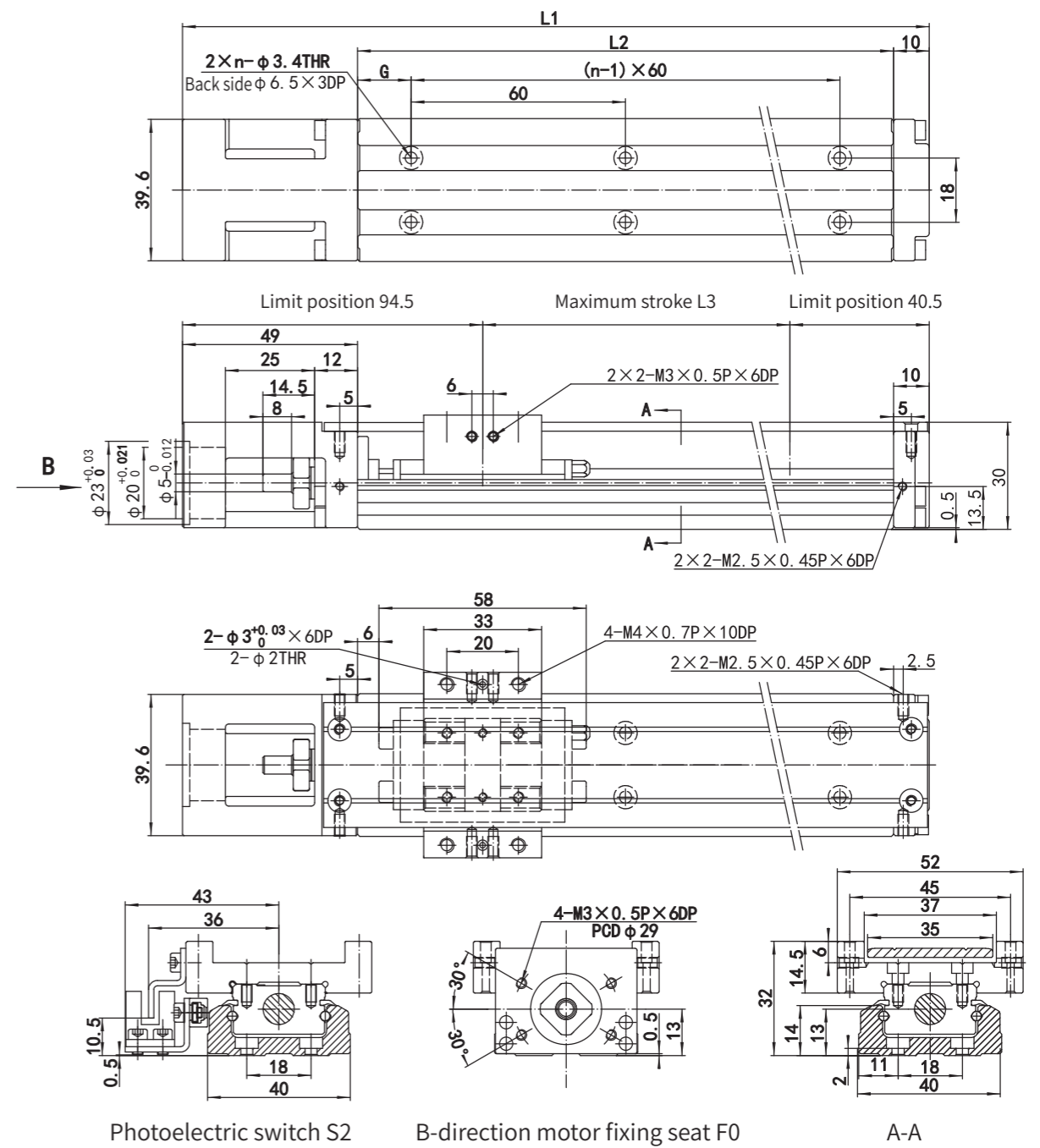

Rail Length L2 (mm)	Total Length (mm)	Maximum Stroke (mm)		G (mm)	K (mm)	n	m	Mass (kg)	
		Block A1	Block A2					Block A1	Block A2
150	220	60	-	25	100	2	2	1.5	-
200	270	110	-	50	100	2	2	1.8	-
300	370	210	135	50	200	3	2	2.4	2.7
400	470	310	235	50	100	4	4	3	3.3
500	570	410	335	50	200	5	3	3.6	3.9
600	670	510	435	50	100	6	6	4.2	4.6

Rail Length L2 (mm)	Total Length (mm)	Maximum Stroke (mm)		G (mm)	K (mm)	n	m	Mass (kg)	
		Block A1	Block A2					Block A1	Block A2
150	220	85	34	25	100	2	2	1.4	1.6
200	270	135	84	50	100	2	2	1.7	1.9
300	370	235	184	50	200	3	2	2.3	2.5
400	470	335	284	50	100	4	4	2.9	3.1
500	570	435	384	50	200	5	3	3.5	3.7
600	670	535	484	50	100	6	6	4.1	4.3

KK60D (Excluding protective cover)

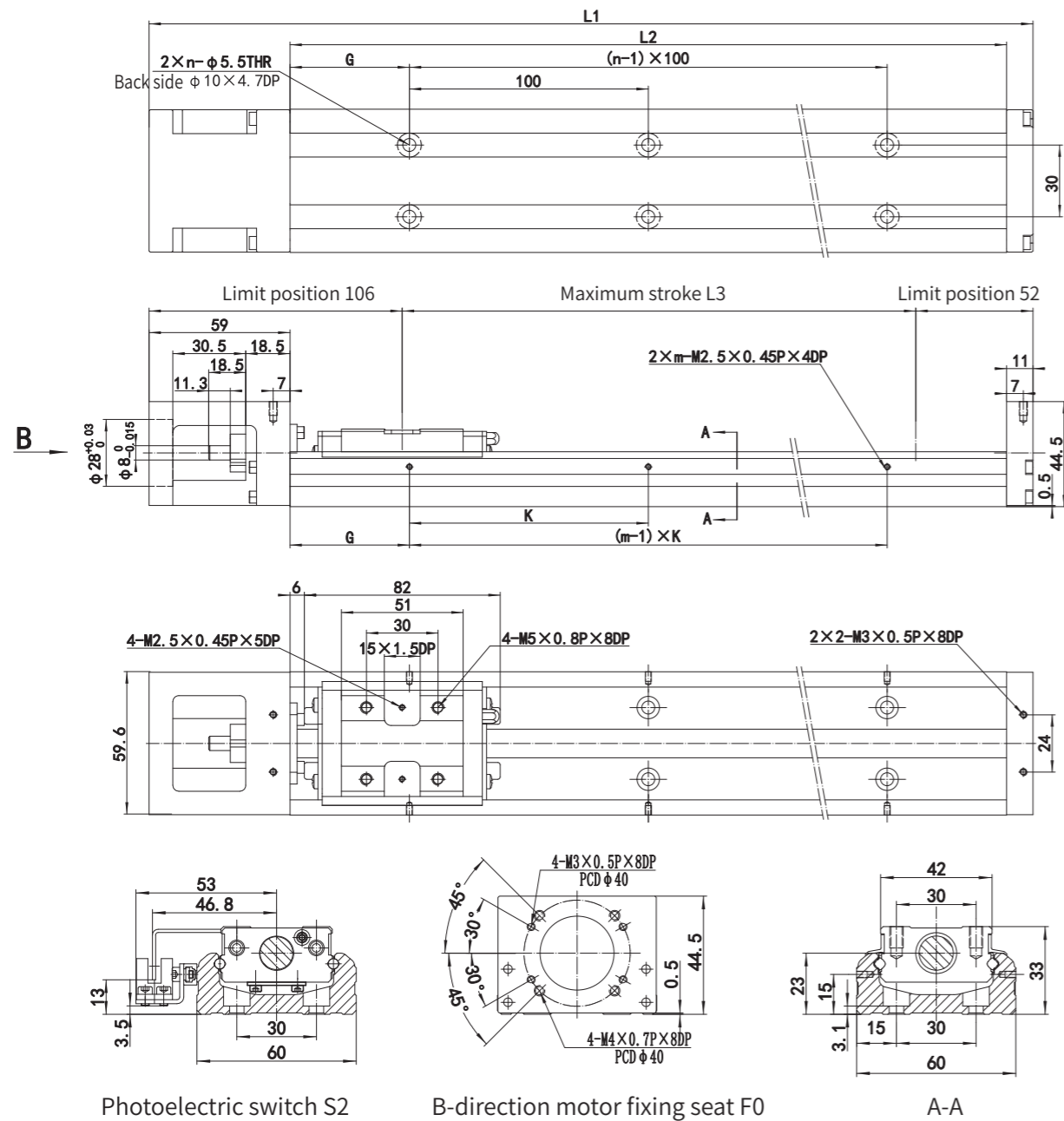

Rail Length L2 (mm)	Total Length (mm)	Maximum Stroke (mm)		G (mm)	K (mm)	n	m	Mass (kg)	
		Block A1	Block A2					Block A1	Block A2
150	220	60	-	25	100	2	2	1.5	-
200	270	110	-	50	100	2	2	1.8	-
300	370	210	135	50	200	3	2	2.4	2.7
400	470	310	235	50	100	4	4	3	3.3
500	570	410	335	50	200	5	3	3.6	3.9
600	670	510	435	50	100	6	6	4.2	4.6

KK60D (Excluding protective cover \ Light load type)

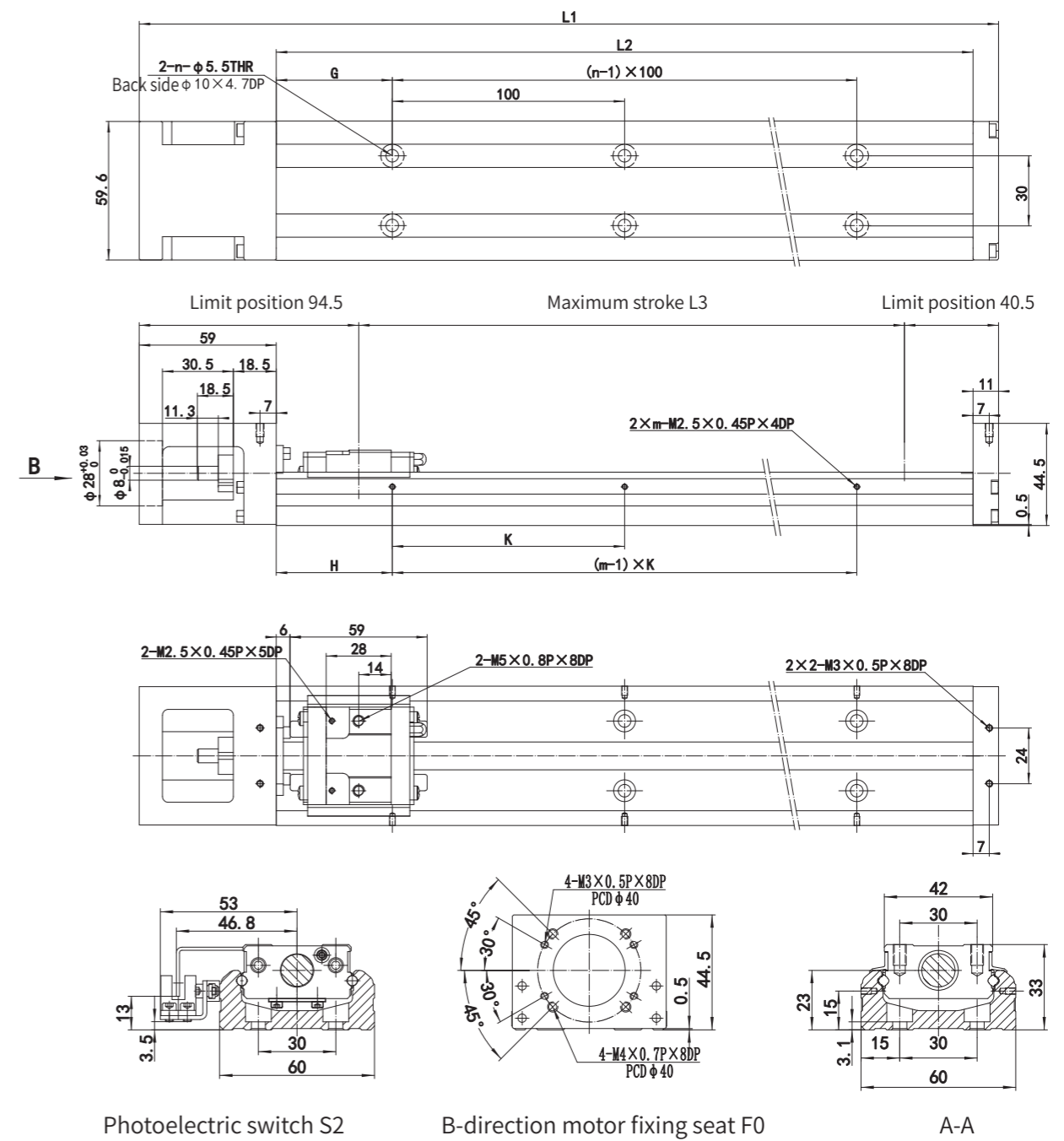

Rail Length L2 (mm)	Total Length (mm)	Maximum Stroke (mm)		G (mm)	K (mm)	n	m	Mass (kg)	
		Block A1	Block A2					Block A1	Block A2
150	220	85	34	25	100	2	2	1.4	1.6
200	270	135	84	50	100	2	2	1.7	1.9
300	370	235	184	50	200	3	2	2.3	2.5
400	470	335	284	50	100	4	4	2.9	3.1
500	570	435	384	50	200	5	3	3.5	3.7
600	670	535	484	50	100	6	6	4.1	4.3

KK86 (Excluding protective cover)

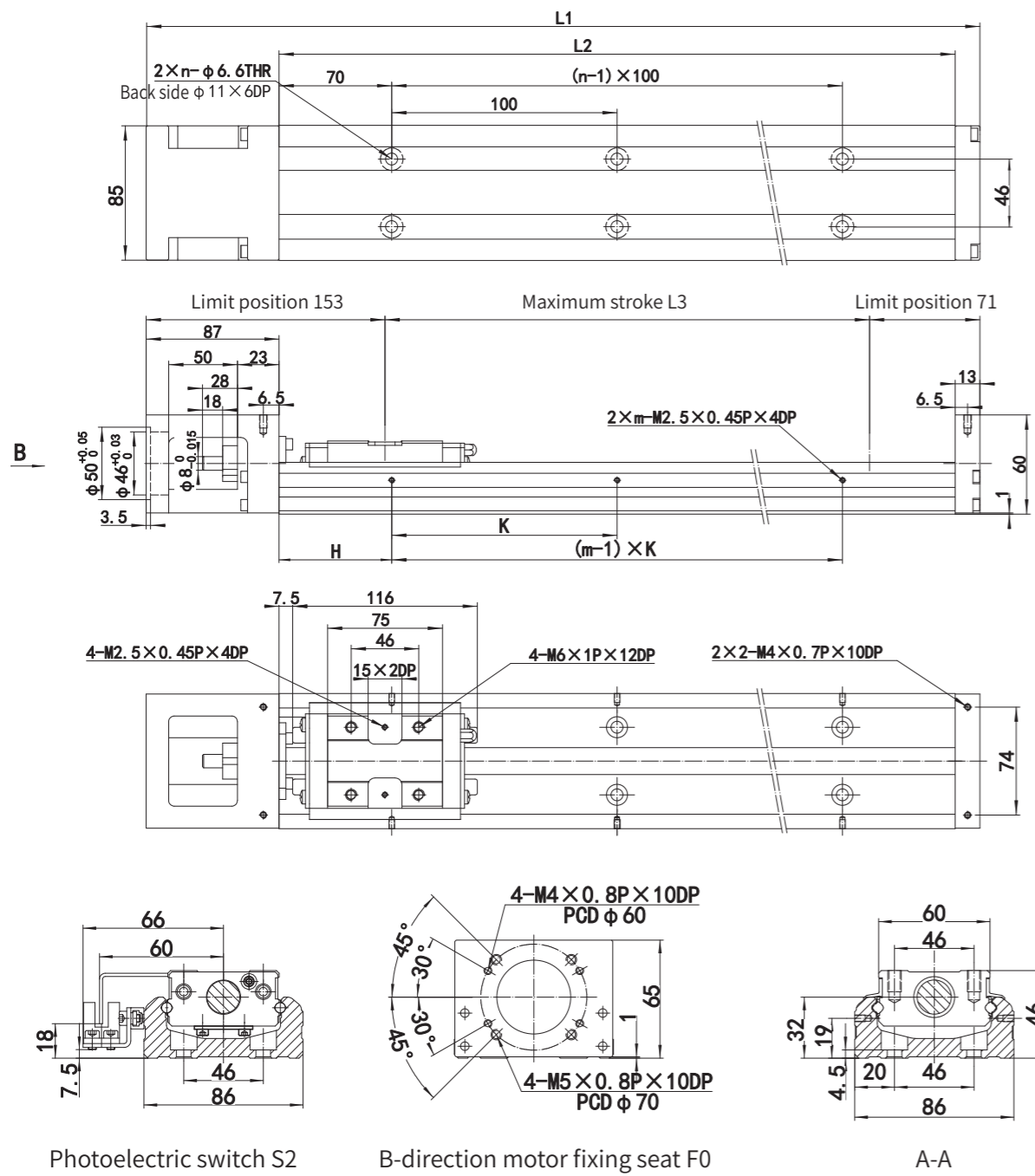

Rail Length L_2 (mm)	Total Length (mm)	Maximum Stroke (mm)		H (mm)	n	m	Mass (kg)	
		Block A1	Block A2				Block A1	Block A2
340	440	216	108	70	3	2	5.7	6.5
440	540	316	208	20	4	3	6.9	7.7
540	640	416	308	70	5	3	8	8.8
640	740	516	408	20	6	4	9.2	10
740	840	616	508	70	7	4	10.4	11.2
940	1040	816	708	70	9	5	11.6	12.4

KK86 (Excluding protective cover \ Light load type)

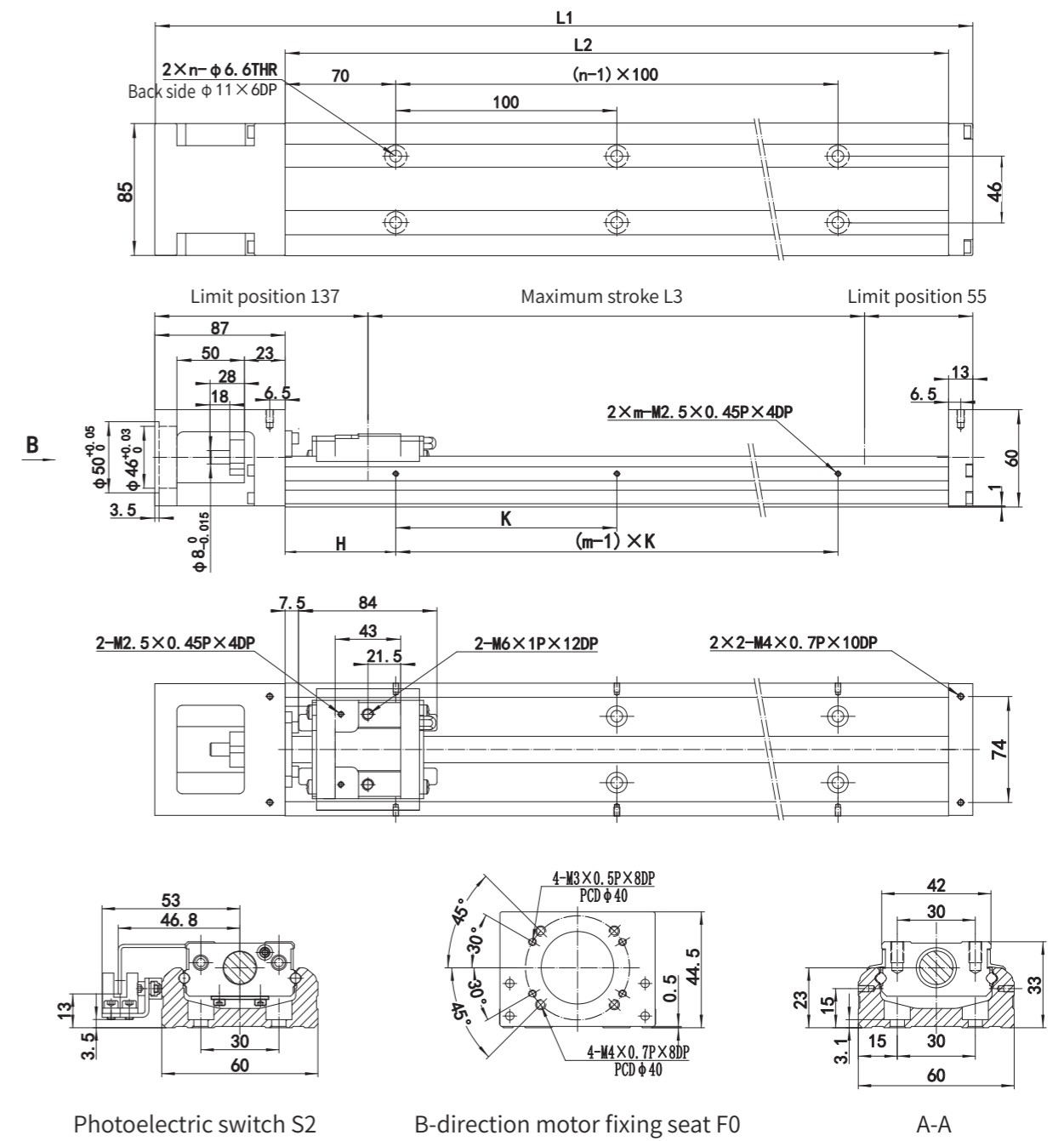

Rail Length L_2 (mm)	Total Length (mm)	Maximum Stroke (mm)		H (mm)	n	m	Mass (kg)	
		Block A1	Block A2				Block A1	Block A2
340	440	248	172	70	3	2	5.4	5.9
440	540	348	272	20	4	3	6.5	7.1
540	640	448	372	70	5	3	7.7	8.2
640	740	548	472	20	6	4	8.9	9.4
740	840	648	572	70	7	4	10.1	10.6
940	1040	848	772	70	9	5	11.3	11.8

KK86D (Excluding protective cover)

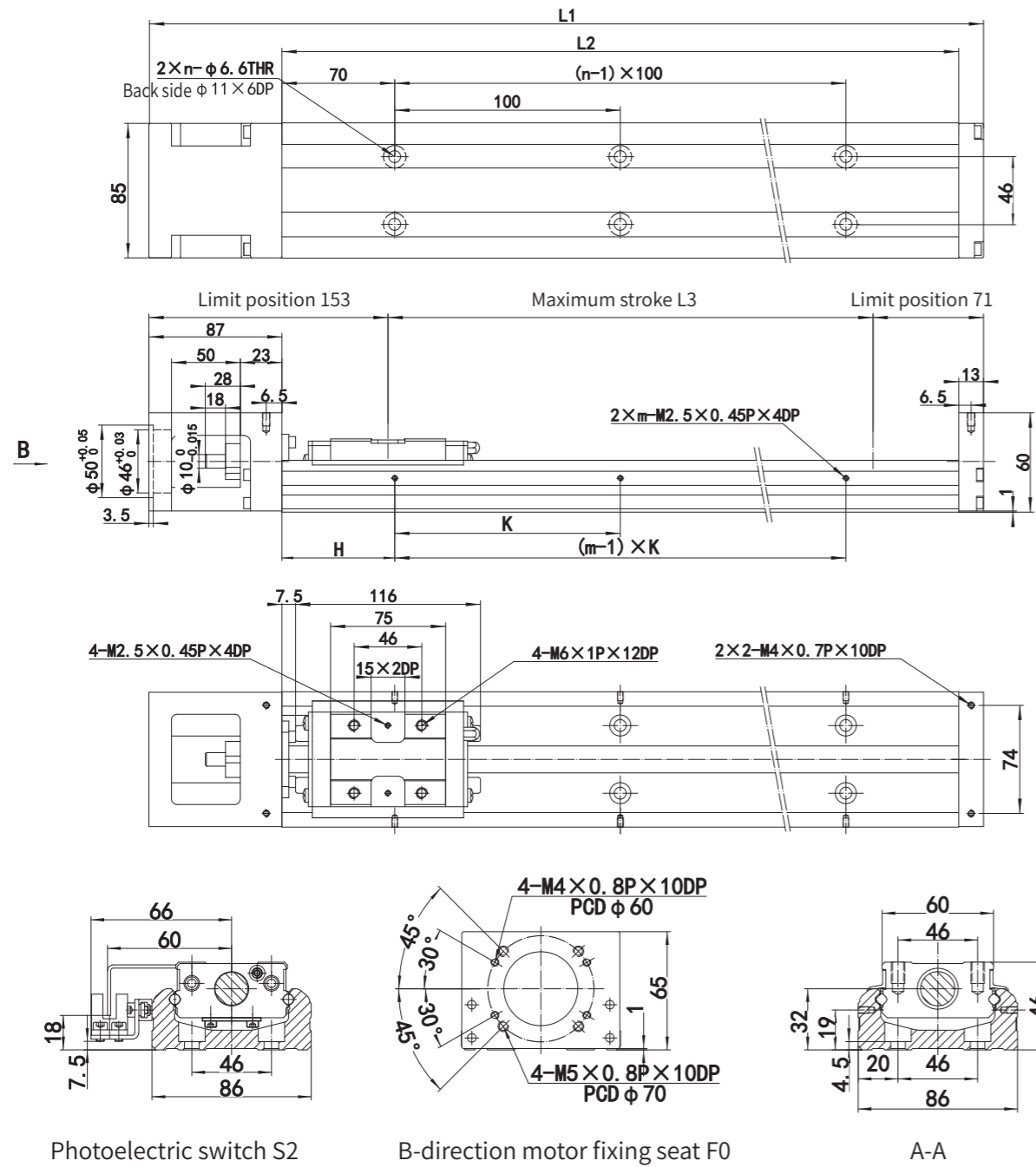

Rail Length L2 (mm)	Total Length (mm)	Maximum Stroke (mm)		H (mm)	n	m	Mass (kg)	
		Block A1	Block A2				Block A1	Block A2
340	440	216	108	70	3	2	5.7	6.5
440	540	316	208	20	4	3	6.9	7.7
540	640	416	308	70	5	3	8	8.8
640	740	516	408	20	6	4	9.2	10
740	840	616	508	70	7	4	10.4	11.2
940	1040	816	708	70	9	5	11.6	12.4

KK86D (Excluding protective cover \ Light load type)

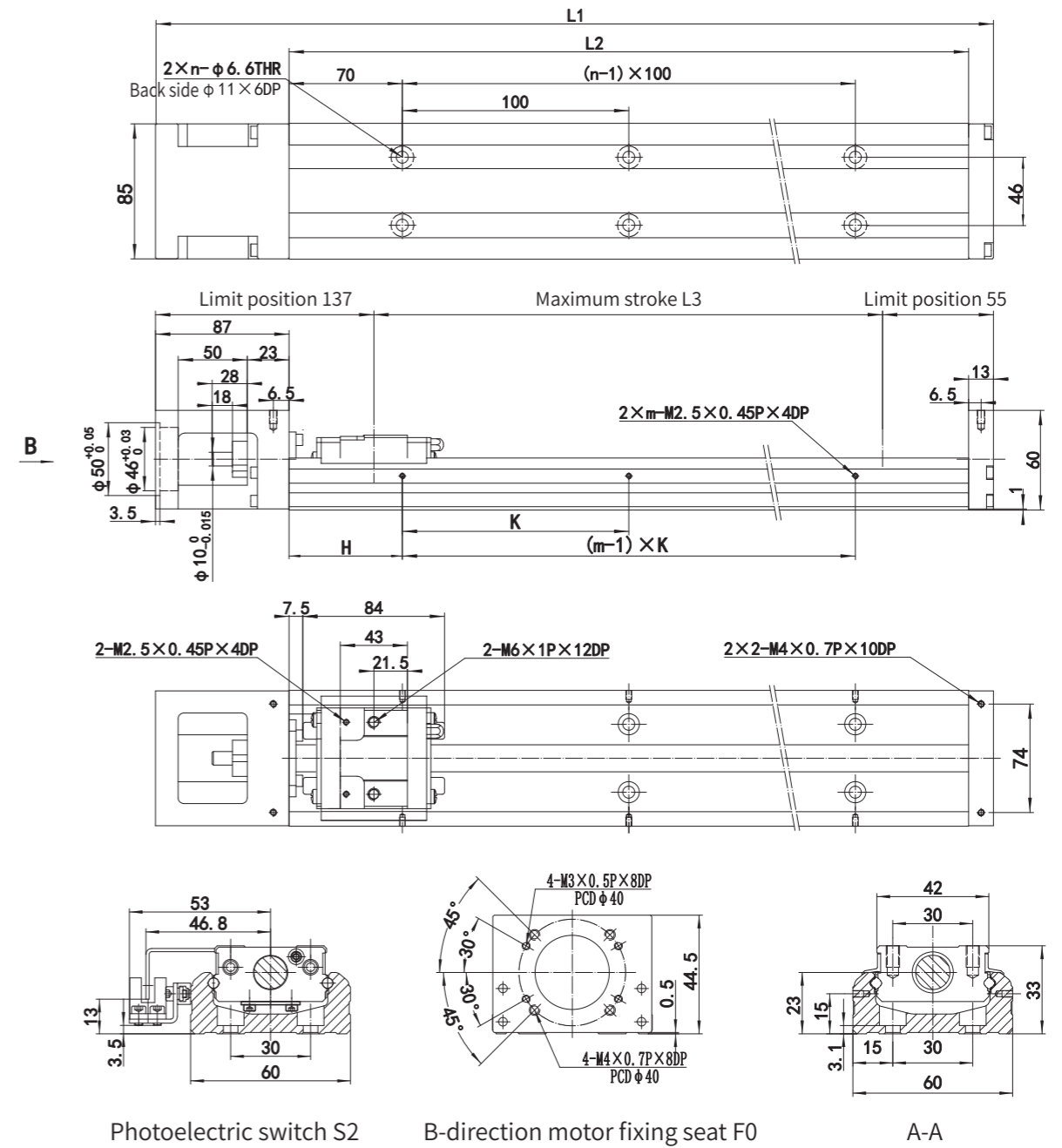

Rail Length L2 (mm)	Total Length (mm)	Maximum Stroke (mm)		H (mm)	n	m	Mass (kg)	
		Block A1	Block A2				Block A1	Block A2
340	440	248	172	70	3	2	5.4	5.9
440	540	348	272	20	4	3	6.6	7.1
540	640	448	372	70	5	3	7.7	8.2
640	740	548	472	20	6	4	8.9	9.4
740	840	648	572	70	7	4	10.1	10.6
940	1040	848	772	70	9	5	11.3	11.8

KK100 (Excluding protective cover)

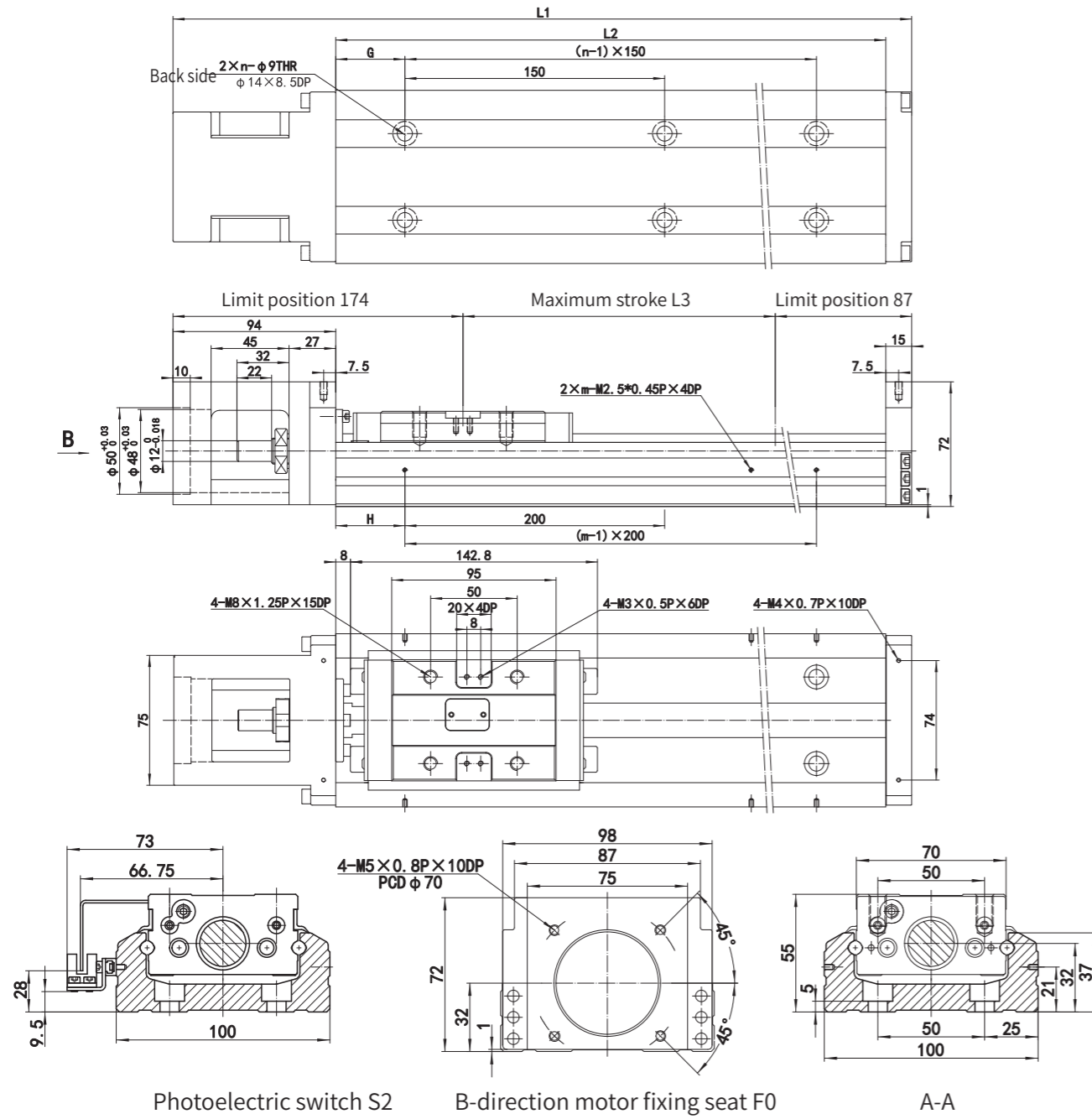

Rail Length L2 (mm)	Total Length (mm)	Maximum Stroke (mm)		G (mm)	K (mm)	n	m	Mass (kg)	
		Block A1	Block A2					Block A1	Block A2
980	1089	828	700	40	90	7	5	18.6	20.3
1080	1189	928	800	15	40	8	6	20.3	22
1180	1289	1028	900	65	90	8	6	22	23.7
1280	1389	1128	1000	40	40	9	7	23.6	25.3
1380	1489	1228	1100	15	90	10	7	25.3	27

KK130 (Excluding protective cover)

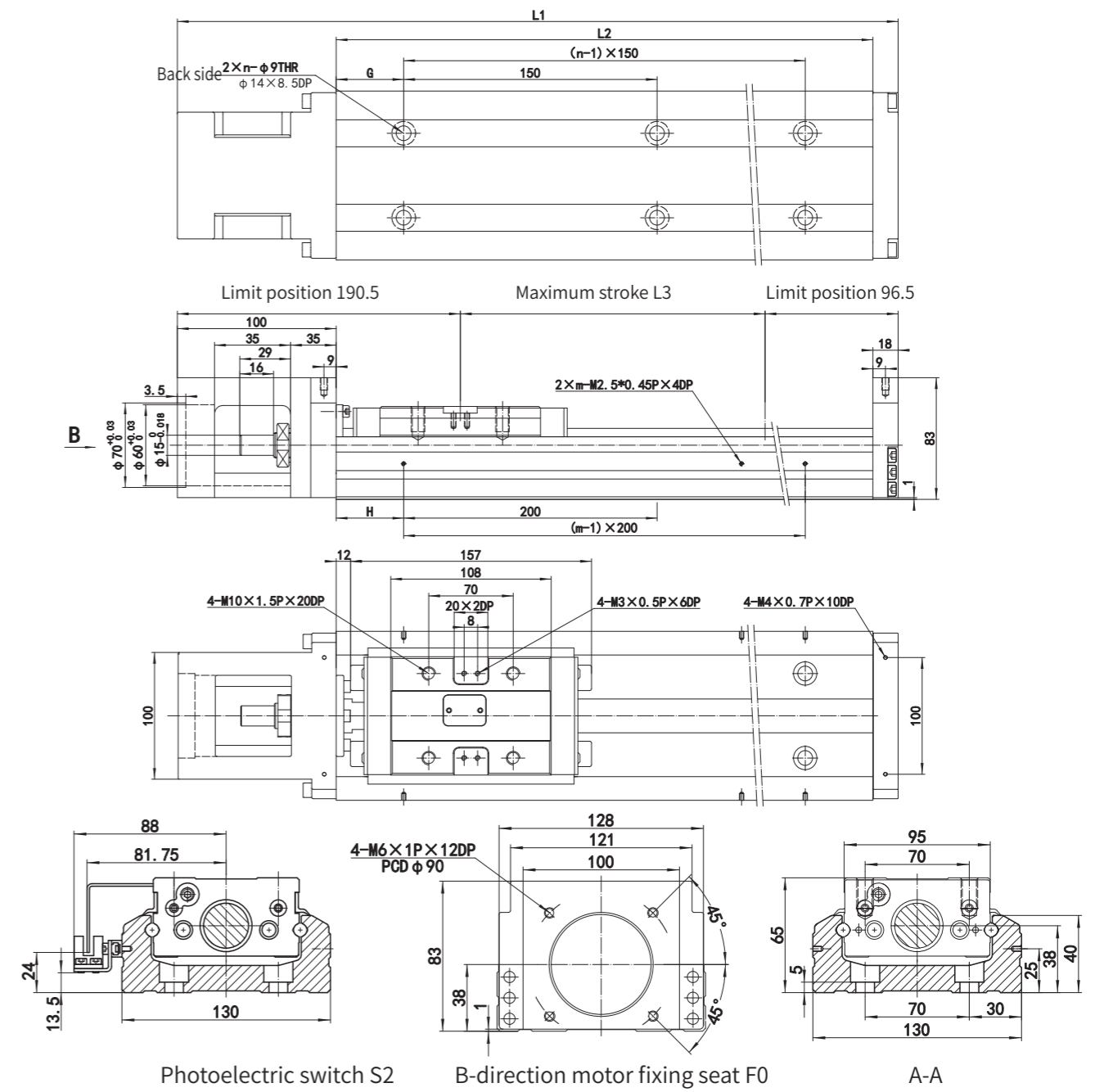

Rail Length L2 (mm)	Total Length (mm)	Maximum Stroke (mm)		G (mm)	K (mm)	n	m	Mass (kg)	
		Block A1	Block A2					Block A1	Block A2
980	1098	811	659	40	90	7	5	29.4	32.3
1180	1298	1011	859	65	90	8	6	34.3	37.2
1380	1498	1211	1059	90	90	9	7	39.2	42.1
1680	1798	1511	1359	90	40	11	9	46.5	49.4

16 Dinghan KK series
KK40 (Including protective cover)

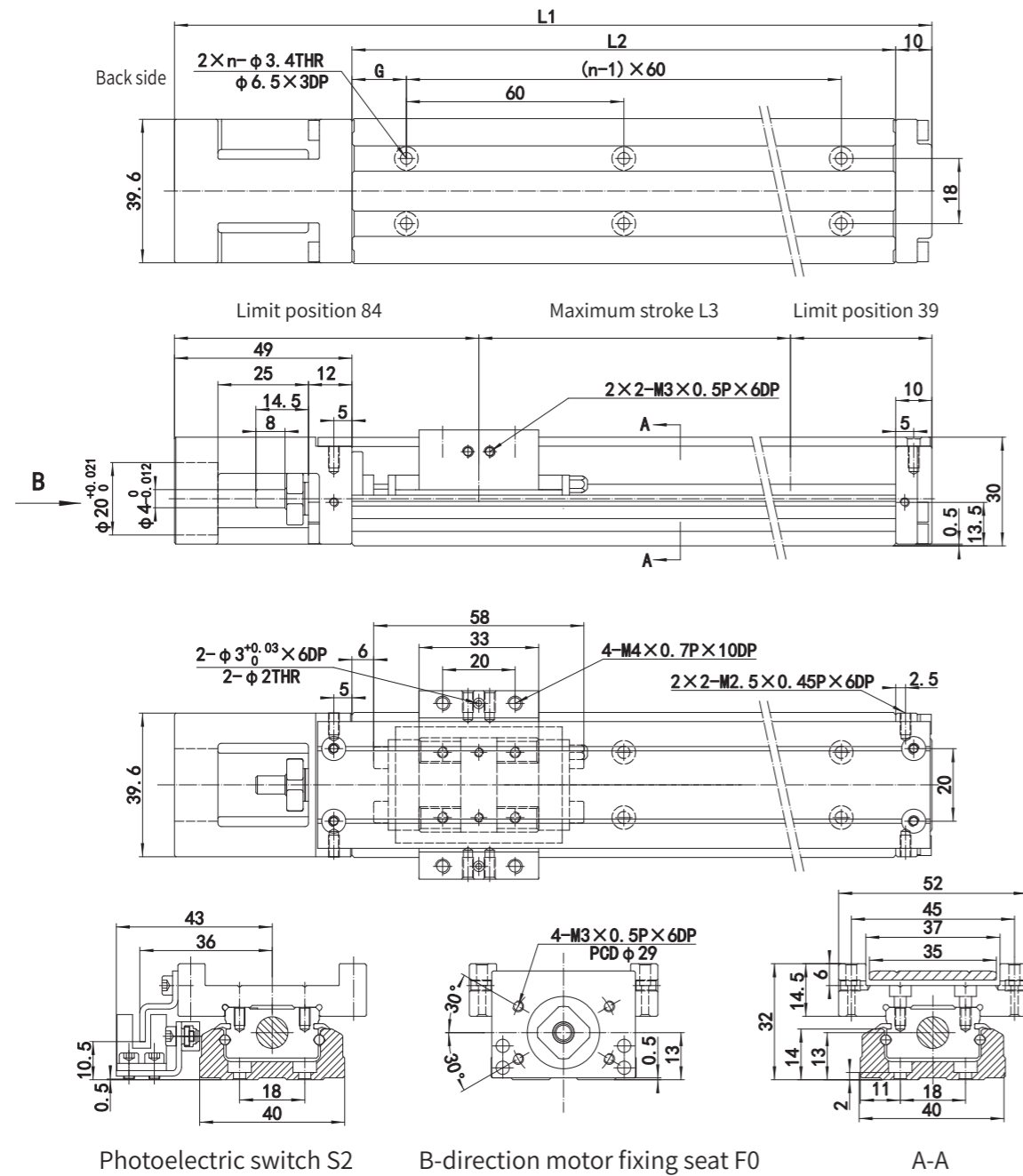

Rail Length L2 (mm)	Total Length (mm)	Maximum Stroke (mm)		G (mm)	n	Mass (kg)	
		Block A1	Block A2			Block A1	Block A2
100	159	36	-	20	2	0.55	-
150	209	86	34	15	3	0.68	0.76
200	259	136	84	40	3	0.82	0.89

KK40D (Including protective cover)

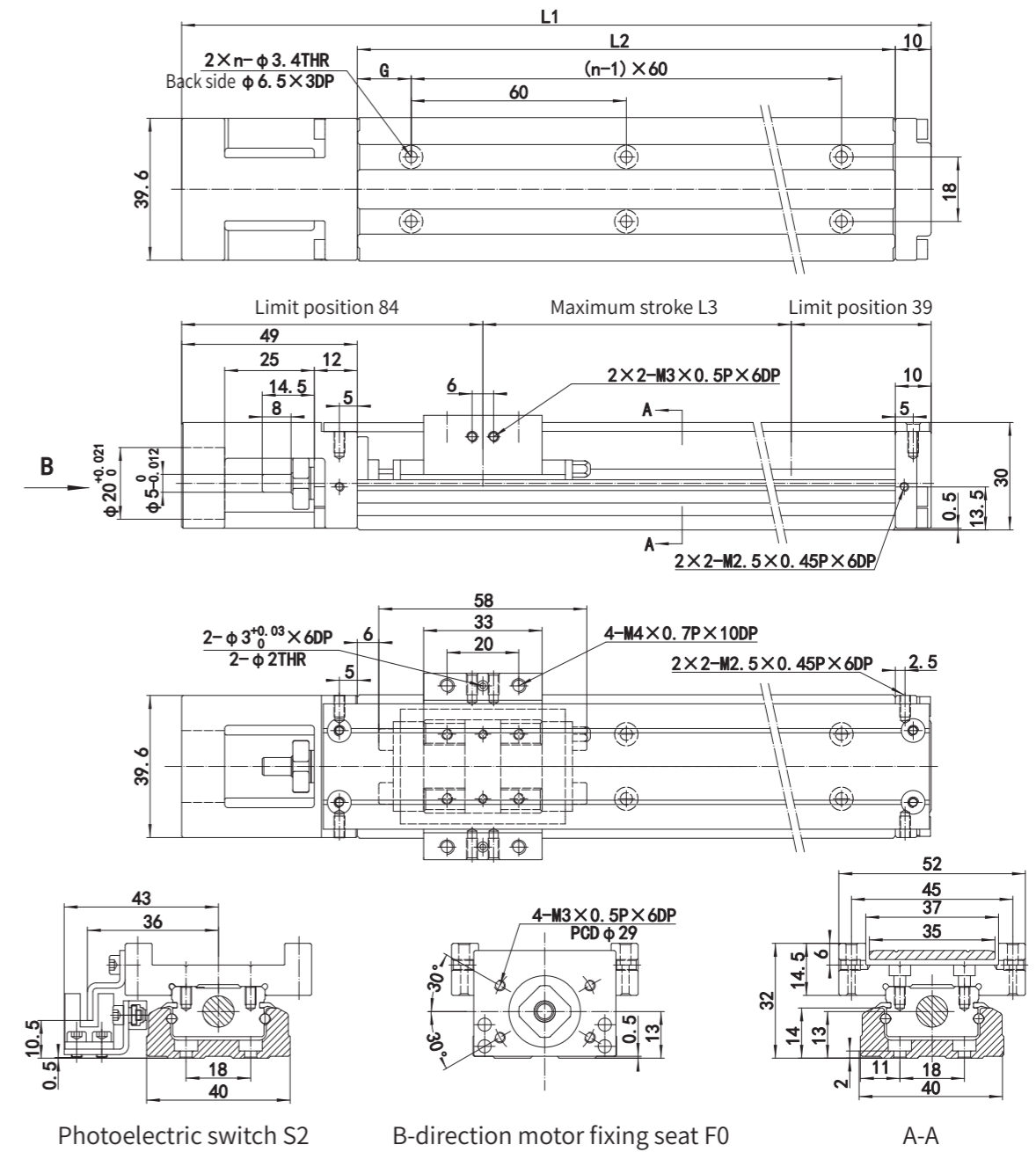

Rail Length L2 (mm)	Total Length (mm)	Maximum Stroke (mm)		G (mm)	n	Mass (kg)	
		Block A1	Block A2			Block A1	Block A2
100	159	36	-	20	2	0.55	-
150	209	86	34	15	3	0.68	0.76
200	259	136	84	40	3	0.82	0.89

KK50 (Including protective cover)

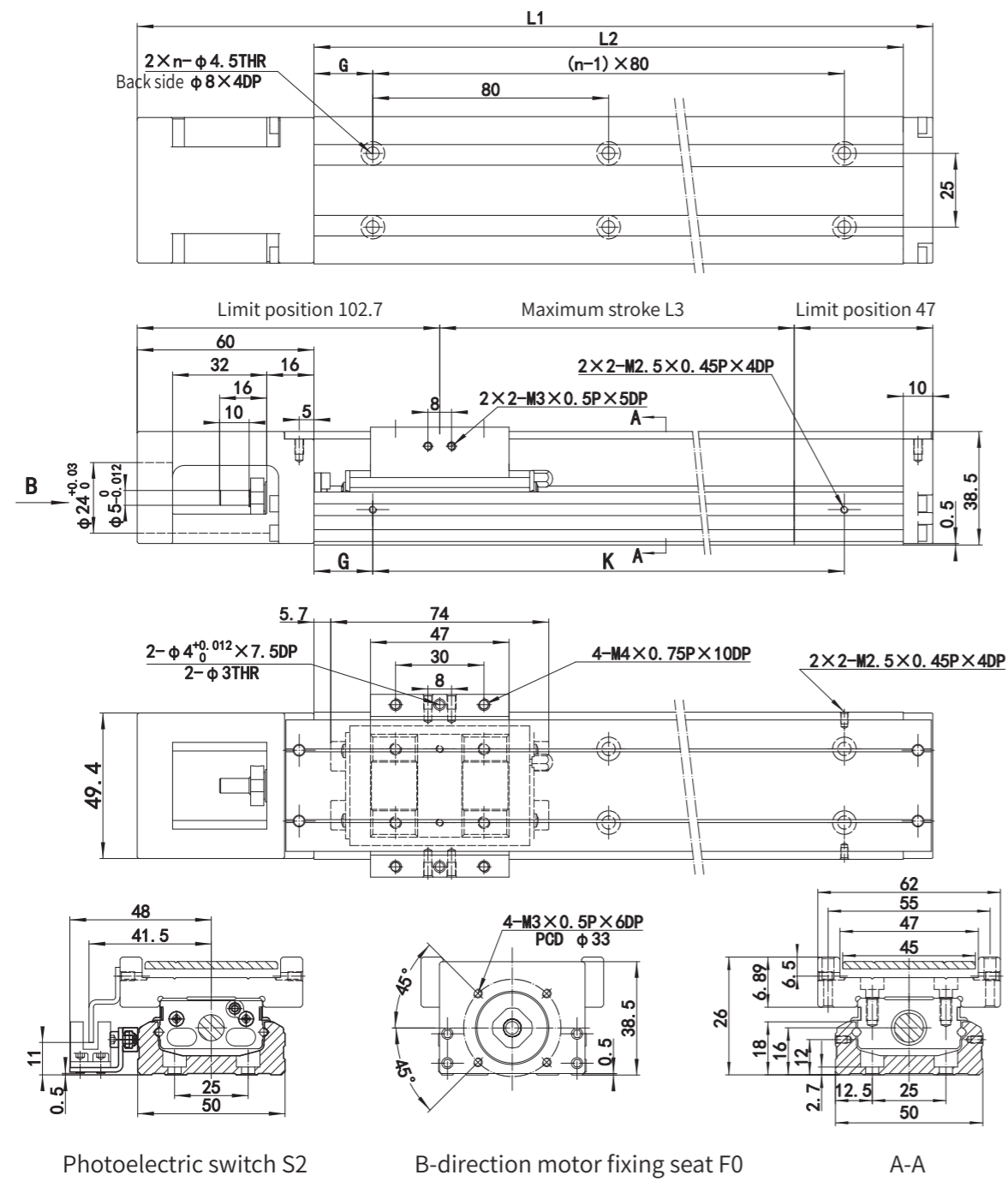

Rail Length L2 (mm)	Total Length (mm)	Maximum Stroke (mm)		G (mm)	K (mm)	n	Mass (kg)	
		Block A1	Block A2				Block A1	Block A2
150	220	70	-	35	80	2	1.1	-
200	270	120	55	20	160	3	1.3	1.5
250	320	170	105	45	160	3	1.6	1.8
300	370	220	150	30	240	4	1.8	2

KK60 (Including protective cover)

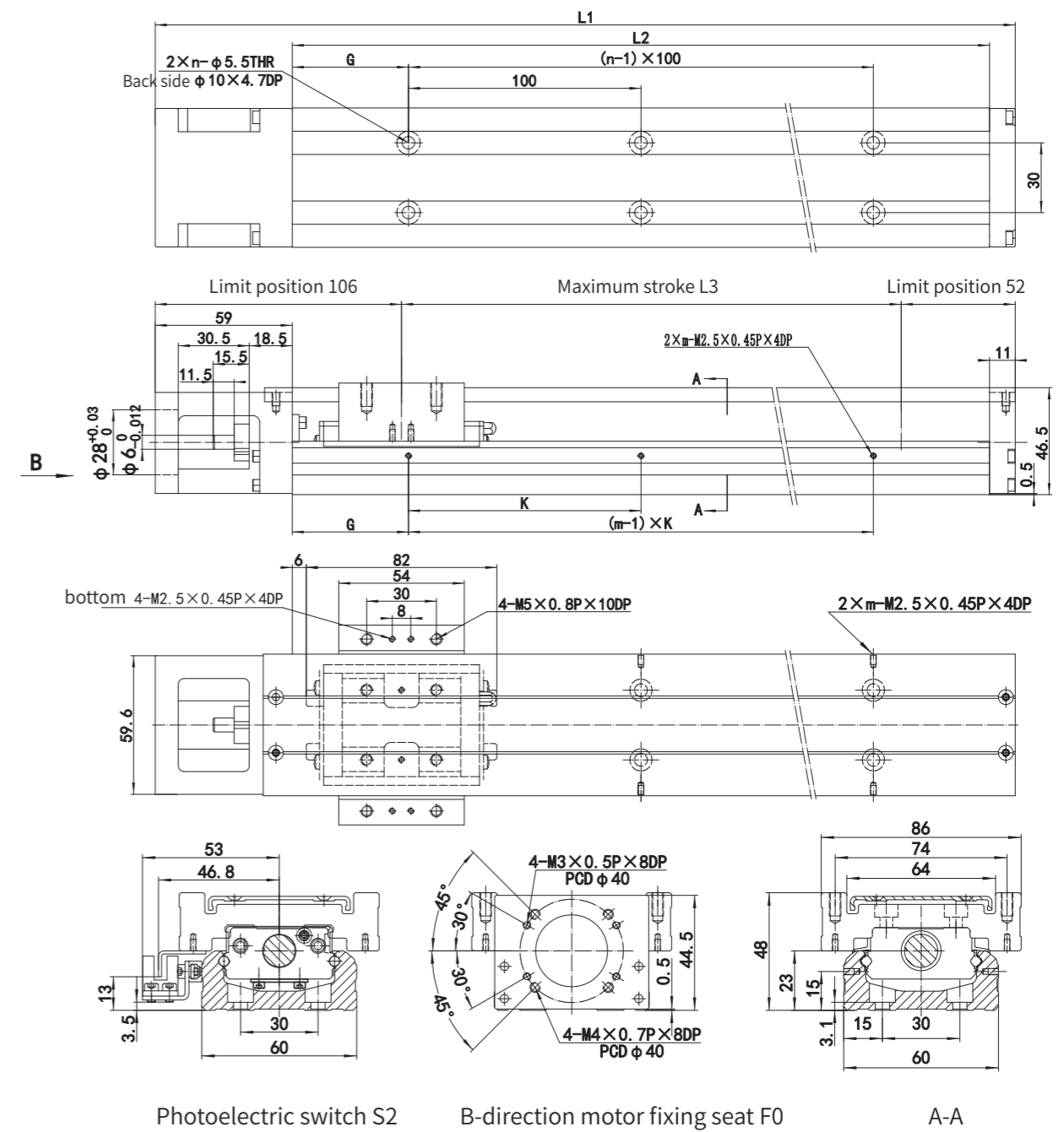

Rail Length L2 (mm)	Total Length (mm)	Maximum Stroke (mm)		G (mm)	K (mm)	n	m	Mass (kg)	
		Block A1	Block A2					Block A1	Block A2
150	220	60	-	25	100	2	2	1.7	-
200	270	110	-	50	100	2	2	2.1	-
300	370	210	135	50	200	3	2	2.7	3.0
400	470	310	235	50	100	4	4	3.3	3.6
500	570	410	335	50	200	5	3	3.9	4.2
600	670	510	435	50	100	6	6	4.6	5.0

KK60D (Including protective cover \ Light load type)

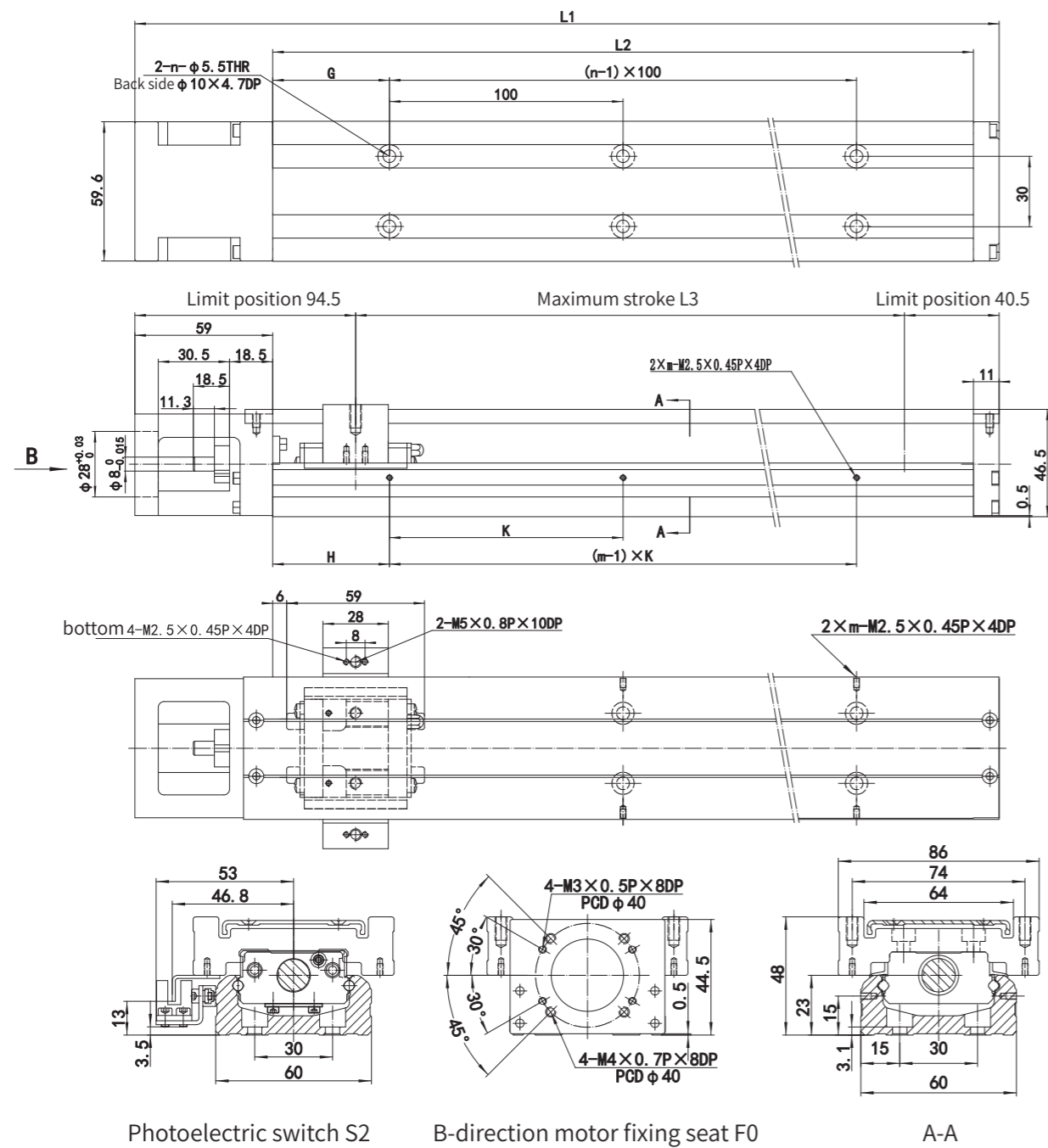

Rail Length L2 (mm)	Total Length (mm)	Maximum Stroke (mm)		G (mm)	K (mm)	n	m	Mass (kg)	
		Block A1	Block A2					Block A1	Block A2
150	220	85	34	25	100	2	2	1.6	1.8
200	270	135	84	50	100	2	2	1.9	2.1
300	370	235	184	50	200	3	2	2.5	2.7
400	470	335	284	50	100	4	4	3.1	3.3
500	570	435	384	50	200	5	3	3.7	3.9
600	670	535	484	50	100	6	6	4.4	4.6

KK86 (Including protective cover)

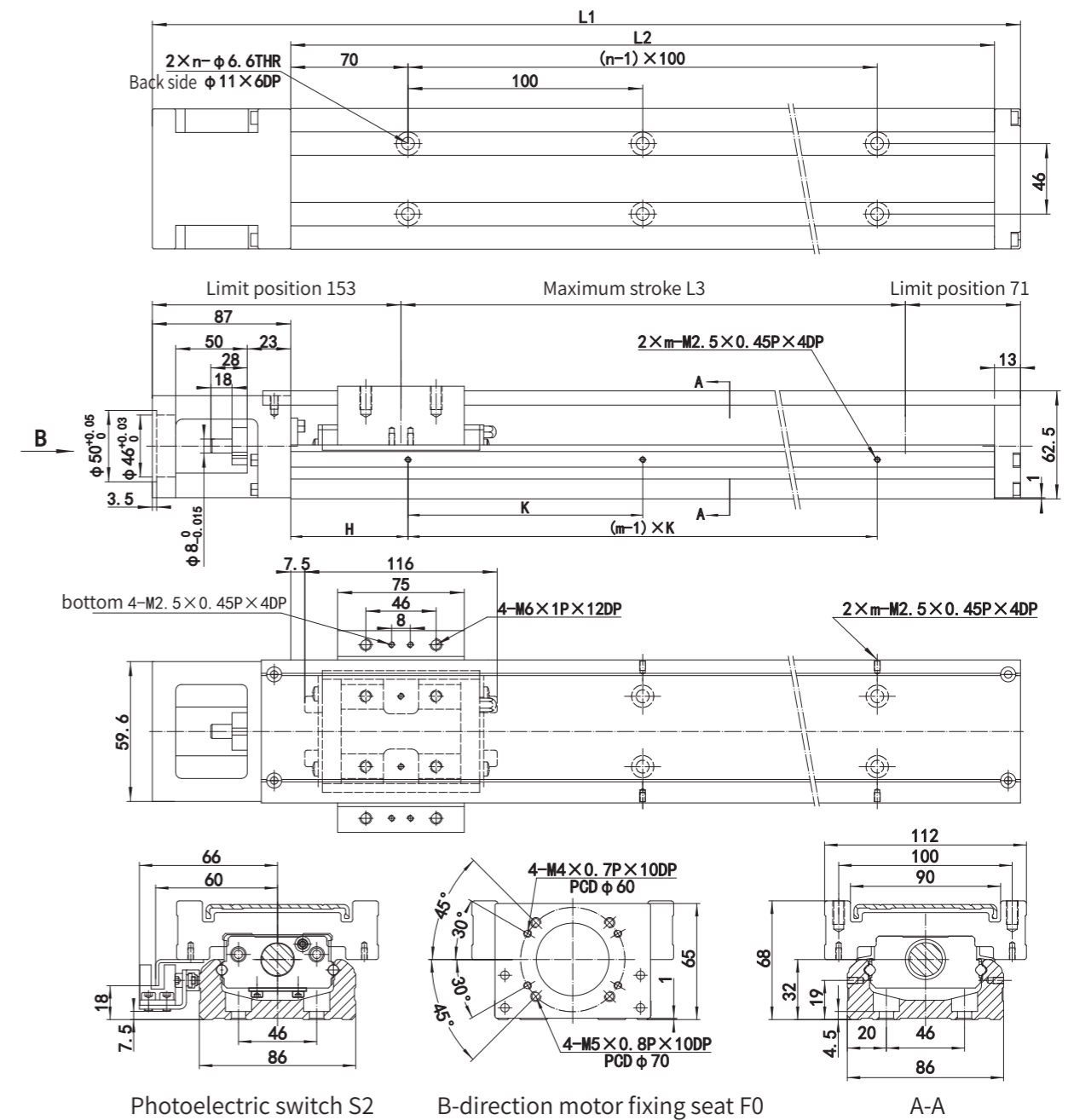

Rail Length L2 (mm)	Total Length (mm)	Maximum Stroke (mm)		H (mm)	n	m	Mass (kg)	
		Block A1	Block A2				Block A1	Block A2
340	440	216	108	70	3	2	6.5	7.3
440	540	316	208	20	4	3	7.8	8.6
540	640	416	308	70	5	3	9	9.8
640	740	516	408	20	6	4	10.3	11.3
740	840	616	508	70	7	4	11.6	12.4
940	1040	816	708	70	9	5	13	13.8

KK86 (Including protective cover \ Light load type)

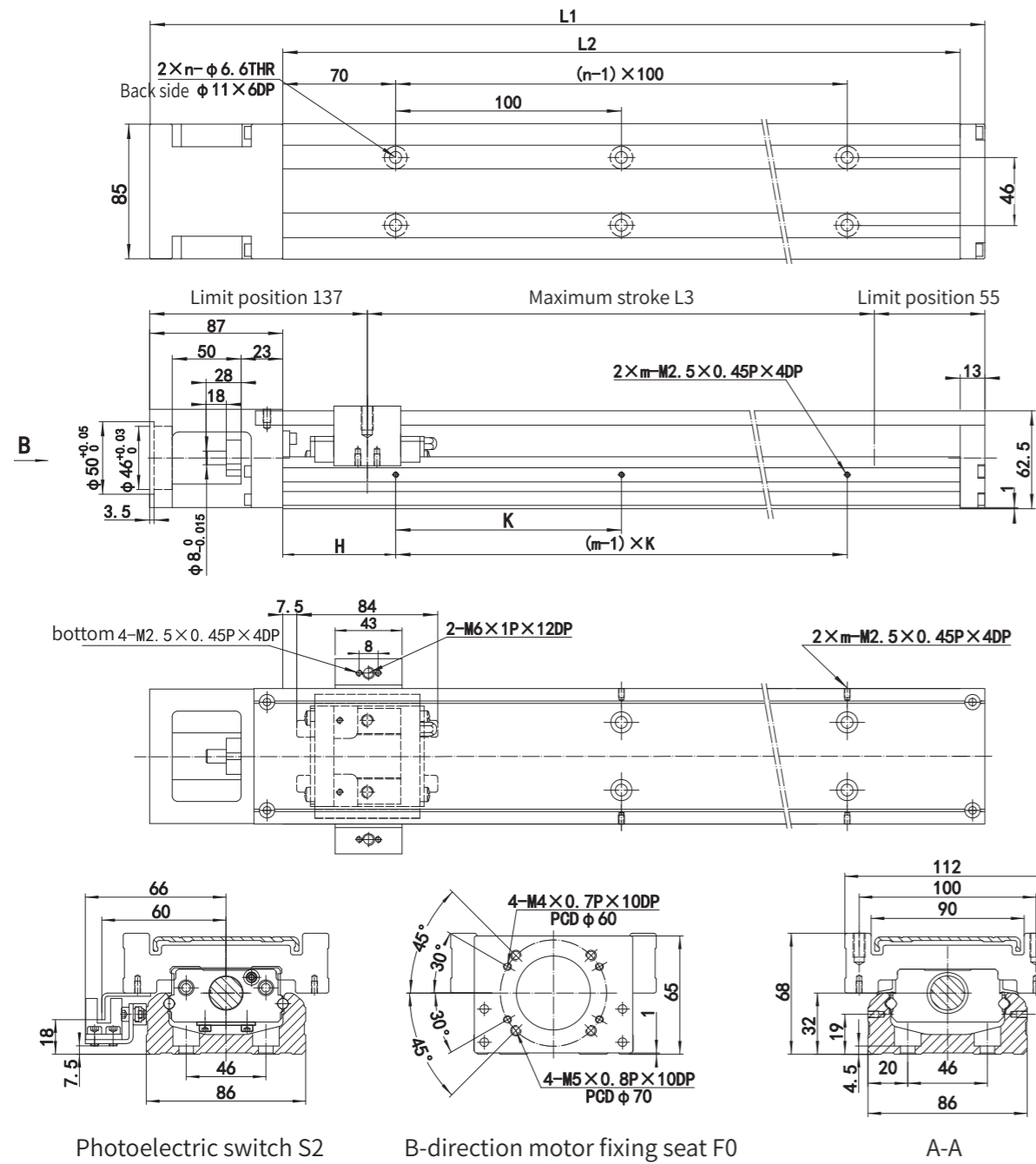

Rail Length L2 (mm)	Total Length (mm)	Maximum Stroke (mm)		H (mm)	n	m	Mass (kg)	
		Block A1	Block A2				Block A1	Block A2
340	440	248	172	70	3	2	6.5	7.3
440	540	348	272	20	4	3	7.8	8.6
540	640	448	372	70	5	3	9	9.8
640	740	548	472	20	6	4	10.3	11.3
740	840	648	572	70	7	4	11.6	12.4
940	1040	848	772	70	9	5	13	13.8

KK86D (Including protective cover)

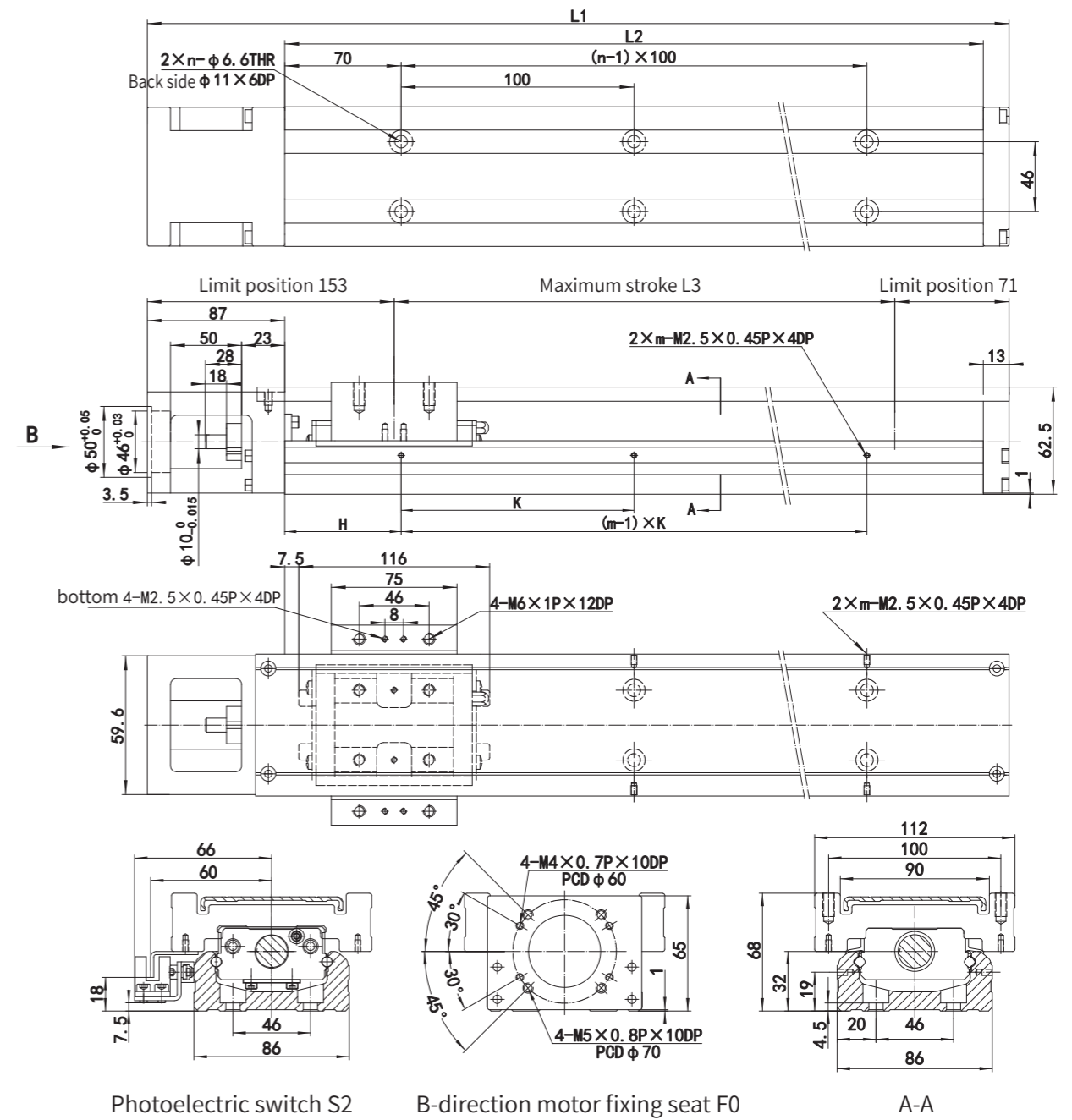

Rail Length L2 (mm)	Total Length (mm)	Maximum Stroke (mm)		H (mm)	n	m	Mass (kg)	
		Block A1	Block A2				Block A1	Block A2
340	440	216	108	70	3	2	6.5	7.3
440	540	316	208	20	4	3	7.8	8.6
540	640	416	308	70	5	3	9	9.8
640	740	516	408	20	6	4	10.3	11.3
740	840	616	508	70	7	4	11.6	12.4
940	1040	816	708	70	9	5	13	13.8

KK86D (Including protective cover \ Light load type)

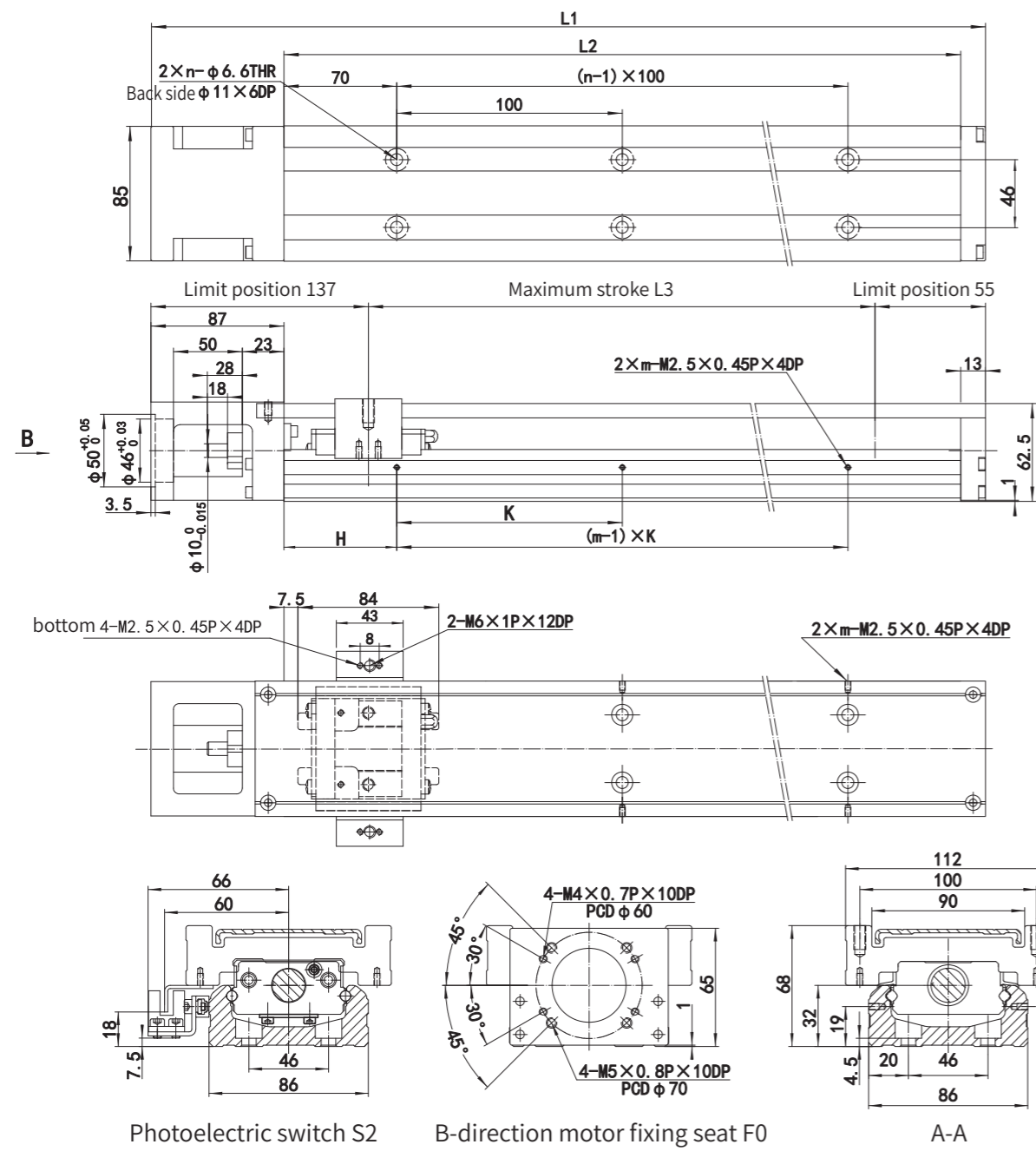

Rail Length L2 (mm)	Total Length (mm)	Maximum Stroke (mm)		H (mm)	n	m	Mass (kg)	
		Block A1	Block A2				Block A1	Block A2
340	440	248	172	70	3	2	6.5	7.3
440	540	348	272	20	4	3	7.8	8.6
540	640	448	372	70	5	3	9	9.8
640	740	548	472	20	6	4	10.3	11.3
740	840	648	572	70	7	4	11.6	12.4
940	1040	848	772	70	9	5	13	13.8

KK100 (Including protective cover)

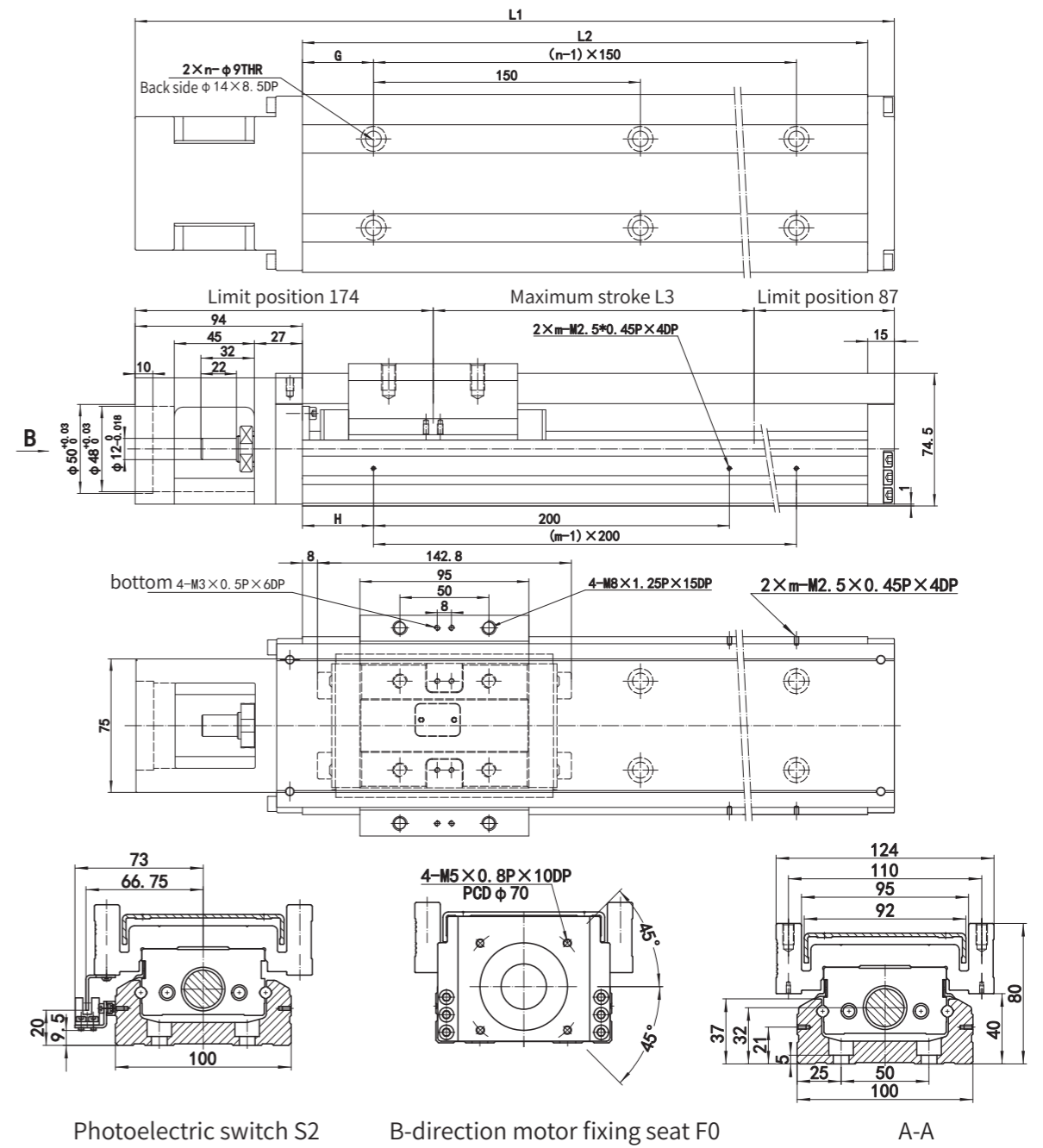

Rail Length L2 (mm)	Total Length (mm)	Maximum Stroke (mm)		G (mm)	K (mm)	n	m	Mass (kg)	
		Block A1	Block A2					Block A1	Block A2
980	1098	828	700	40	90	7	5	20.4	22.1
1080	1189	928	800	15	40	8	6	22.2	23.9
1180	1289	1028	900	65	90	8	6	24	25.7
1280	1389	1128	1000	40	40	9	7	25.7	27.4
1380	1489	1228	1100	15	90	10	7	27.5	29.2

KK130 (Including protective cover)

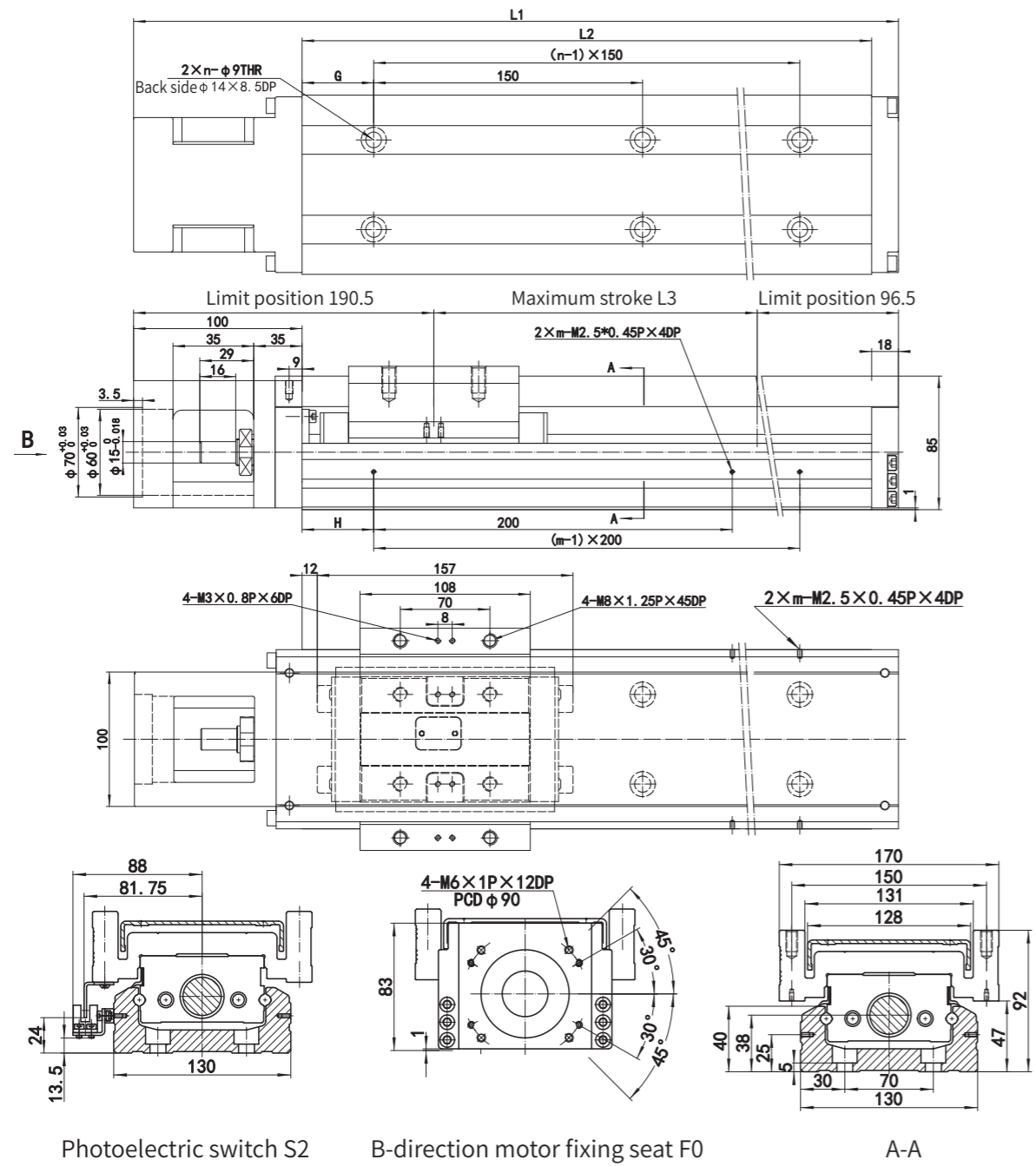

Rail Length L2 (mm)	Total Length (mm)	Maximum Stroke (mm)		G (mm)	K (mm)	n	m	Mass (kg)	
		Block A1	Block A2					Block A1	Block A2
980	1098	811	659	40	90	7	5	31.9	35.9
1180	1298	1011	859	65	90	8	6	37.1	41.1
1380	1498	1211	1059	90	90	9	7	42.2	46.2
1680	1798	1511	1359	90	40	11	9	49.9	53.9

Precision Ball Screw Data Collection Form

Company Name : _____ Date : year _____ Month _____ Day _____ Form filler: _____
 Address : _____
 TEL : _____ Cell phone: _____ WeChat ID: _____ FAX: _____
 Device Name: _____ Model: _____ Axis direction: X axis Y axis Z axis
 Guideways Type: Steel ball Steel column Hard track. Is there a diagram attached: Yes (Drawing No. _____) None

1. Operating conditions:

Required service life	Hour	Vibration/impact load	<input type="checkbox"/> Smooth and impact free operation
lubrication method	<input type="checkbox"/> Lubricating oil		<input type="checkbox"/> Ordinary operation
	<input type="checkbox"/> Grease	<input type="checkbox"/> Other	<input type="checkbox"/> Operation accompanied by impact
Usage environment	<input type="checkbox"/> General environment		<input type="checkbox"/> High dust prevention demand
	<input type="checkbox"/> Vacuum environment (Pressure value _____ Torr/mmHg)	<input type="checkbox"/> Other: _____	
	<input type="checkbox"/> High temperature (Temperature _____ °C _____ °F)		

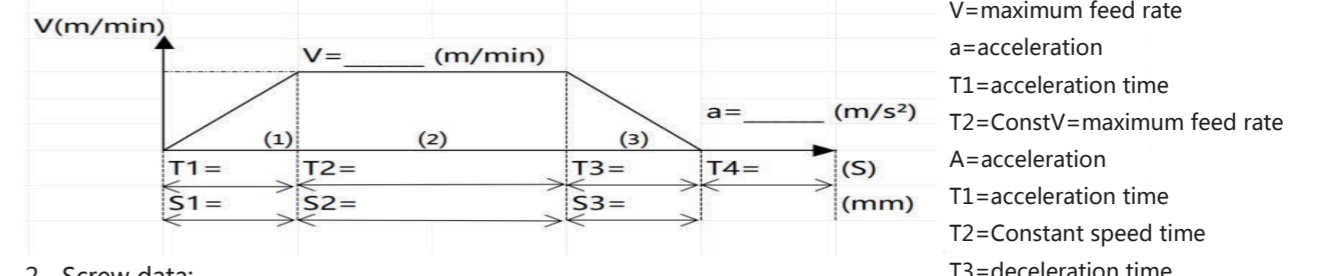

2. Screw data:

movement pattern	<input type="checkbox"/> Axis rotation	Screw type	Rollled	Preload	kgf
	<input type="checkbox"/> Nut rotation		Ground	Preloading torque	Kgf-cm
Thread rotation direction	<input type="checkbox"/> right-handed	Lead accuracy	μm	What bearings	<input type="checkbox"/> Ball bearing
	<input type="checkbox"/> Left-handed			e300\mm	Type number:
Attached scraper brush	<input type="checkbox"/> Yes	Note			
	<input type="checkbox"/> No		Contact angle:		

3. Horizontal device:

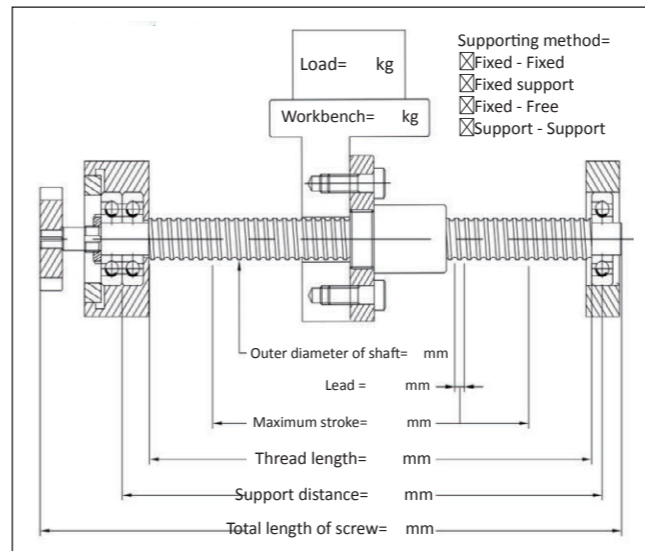

4. Vertical device:

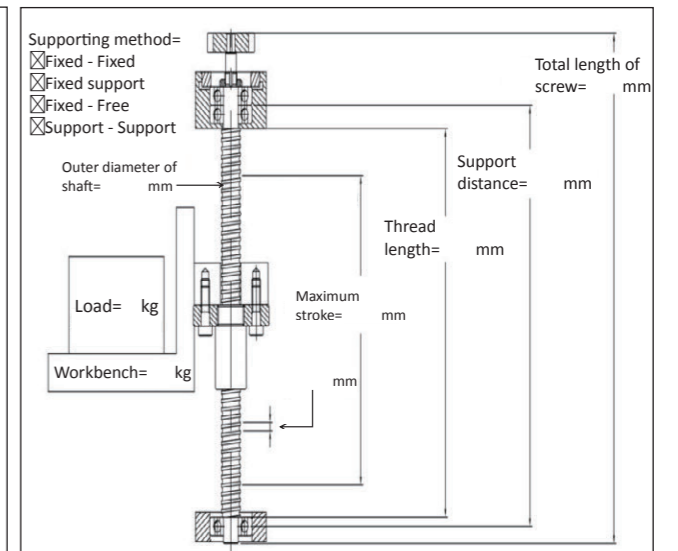

COMPANY PROFILE



SHAC DINGHAN predecessor "LISHUI YINGTE" was founded in 2007, is a modern enterprise specializing in R&D, manufacturing, sales and after-sales of linear transmission components.

In 2007, Dinghan invested the first production line of ball screw in LISHUI, then 16 million dollars was invested to build three modern production lines, including for rolling ball screw, grinding ball screw and precision ball screw nut.

In 2011, Taiwan Dinghan Transmission Technology Co., Ltd was founded in TAIWAN as a research and development center of the company.

In 2013, Dinghan invested 21 million dollars registered LISHUI JIEXIANG TECHNOLOGY CO., LTD as factory base to expand the reproduction of linear guideway and block, the base around 45000 square meters.

In 2016, Lishui Jiexiang has been rated as a national high-tech enterprise, strictly follows the international standards such as ISO9001, ISO14001, ISO45001 etc.

In 2020, ZHEJIANG JIANZHUANG TRANSMISSION TECHNOLOGY CO., LTD registered and second factory base around 65000 square meter put into production.

DINGHAN has been firmly committed to the business direction of "Production specialization, product branding, market internationalization", provide high-quality products to meet the requirements of market and customers so as to achieve stable development. SHAC products are widely used in various high-tech industries and have established stable strategic cooperation with top rank enterprises in domestic and foreign industries, such as automation, CNC machinery, medical equipment, lithium battery and photovoltaic industries.

DINGHAN enterprises adhering to the "Quality first, The credibility of service first, Quality is the mission entrusted by the market".

Innovation, continuous search, customer satisfaction will be our greatest happiness.

Wholeheartedly welcome customers to visit, negotiate and cooperation!



PERFECT PRODUCTS COME FROM CONSUMMATE PRODUCTION